

3.2 mm x 2.5 mm 6 Pads SMD TCXO or TC/VCXO Oscillator

I593 / I793 Series

Product Features:

Advanced PLL Technology
1.5 pSec Phase Jitter typ.
Fast Delivery
RoHS and Lead Free Compliant

Applications:

Server & Storage
CDMA / WCDMA
802.11 / Wifi
T1/E1, T3/E3

Frequency LVCMOS LVPECL LVDS	10.000 MHz to 245.000 MHz 10.000 MHz to 1450.000 MHz 10.000 MHz to 1450.000 MHz
Output Levels LVCMOS LVPECL LVDS	Logic "0" = 10% of Vcc max Logic "1" = 90% of Vcc min Logic "0" = Vcc - 1.85 Vmin, Vcc - 1.60 V max Logic "1" = Vcc - 1.03 V min, Vcc - 0.60 V max Logic "0" = 1.10 V typ, 0.90 V min Logic "1" = 1.40 V typ, 1.60 V max
Load LVCMOS LVPECL LVDS	15pF Differential Differential
Duty Cycle	50% ±5% (Ref to 50% of waveform)
Rise / Fall Time LVCMOS LVPECL LVDS	1.5 nSec typ, 3.0 nSec max (10% to 90% of waveform) 0.2 nSec typ, 0.5 nSec max (20% to 80% of waveform) 0.2 nSec typ, 0.4 nSec max (20% to 80% of waveform)
Frequency Stability Initial Calibration Tolerance vs. Temperature vs. Aging vs. Voltage vs. Load vs. Reflow	±1.0 ppm max at +25°C ±2°C at time of shipment See Stability in Part Number Guide ±1.0 ppm max per year at +25°C ±0.2 ppm max for a ±5% change in Supply Voltage (Vcc) ±0.2 ppm max for a ±10% change in load ±1.0 ppm max after 1 reflow and measured 24 hours after.
Start-up Time	5 mSec max
Supply Voltage (±5%)	+2.50 VDC , +3.30 VDC See Part Number Guide
Current	See table 1 sheet 2
Current with Output Disabled	18 mA typ
Phase Noise (RMS)	1.5 pSec typ (12.000 kHz to 20.000 MHz) Less than 400nSec (1.875 kHz to 21.000 MHz)
Temperature Range Operating Storage	See Operating Temperature in Part Number Guide -55°C to +150°C
Notes:	A 0.01 µF and 10 µF bypass capacitors are recommended between Vcc (Pin 6) and GND (Pin 3) to minimize power supply noise.

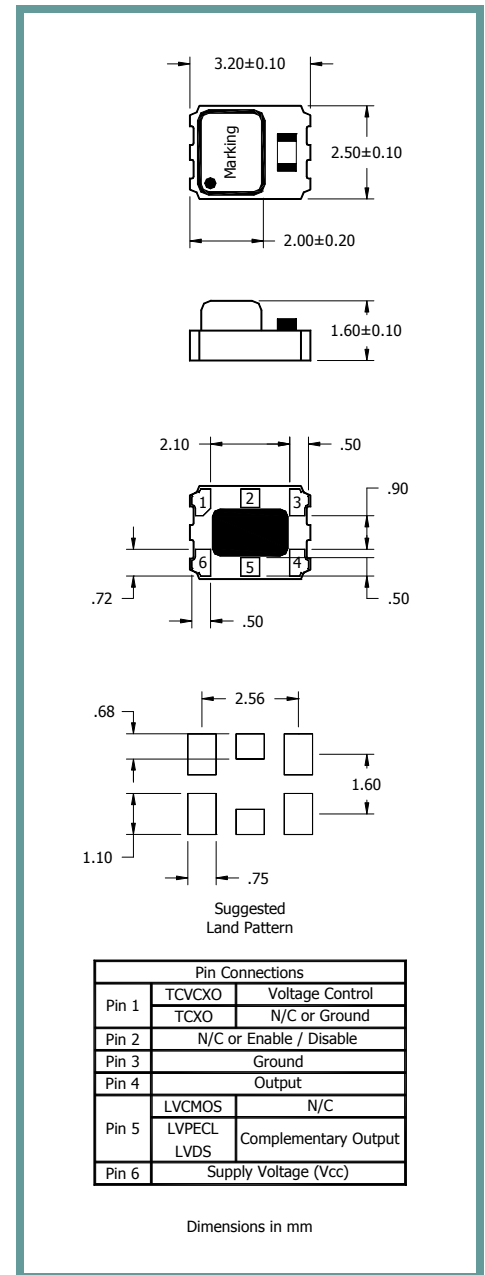

Part Number Guide				Sample Part Number: I593-63Q8H-20.000		
Package	Input Voltage	Operating Temperature	Stability (in ppm)	Output	Enable / Disable (Pin 2)	Frequency
I593 = TCXO	3 = +3.3 V	1 = 0°C to +70°C	0 = ±1.5*	3 = LVCMOS	H = Enable	20.000 MHz
	6 = +2.5 V	2 = -40°C to 85°C	P = ±2.0*	8 = LVDS	O = N/C	
I793 = VCXO		3 = -20°C to +70°C	Q = ±2.5*	9 = LVPECL		
		5 = -30°C to +85°C	R = ±3.0			
			J = ±5.0			

* Not available for all temperature ranges.

3.2 mm x 2.5 mm 6 Pads SMD TCXO or TC/VCXO Oscillator

I593 / I793 Series

Pin Select Functions

Voltage Control Function (Pin 1) I793 only		E/D Function (Pin 2)	
VC Voltage Center & Range	+1.5 V \pm 1.0 V for both Vcc = +2.5 V & +3.3 V	E/D Control	0.7% of Vcc min or no connection enable output 0.3% of Vcc max to disable output (high impedance)
Frequency Pull Range	\pm 8.0 ppm	E/D Time	200 nSec max
Linearity	\pm 1% typ, \pm 10% max	Disable Time	50 nSec max
Transfer Function	Positive		
Absolute Voltage			
Vcc = +3.3 VDC	+3.63 VDC max		
Vcc = +2.5 VDC	+2.63 VDC max		
Input Impedance	770 k Ω typ		
Harmonics	-5.0 dBc max		

SSB Phase Noise

Offset	125.00	212.50	312.50
10 Hz	-51 dBc/Hz	-42 dBc/Hz	-49 dBc/Hz
100 Hz	-83 dBc/Hz	-87 dBc/Hz	-88 dBc/Hz
1 kHz	-111 dBc/Hz	-105 dBc/Hz	-107 dBc/Hz
10 kHz	-123 dBc/Hz	-115 dBc/Hz	-111 dBc/Hz
100 kHz	-125 dBc/Hz	-118 dBc/Hz	-114 dBc/Hz
1 MHz	-135 dBc/Hz	-130 dBc/Hz	-124 dBc/Hz
10 MHz	-155 dBc/Hz	-151 dBc/Hz	-147 dBc/Hz

Supply Current

Current Consumption	LVC MOS	LVPECL	LVDS
Vcc = +2.50 VDC All values are typical an over the operating temperature.	50 MHz = 24mA 125 MHz = 28 mA 200 MHz = 30 mA	156 MHz = 36mA 600 MHz = 40mA 800 MHz = 46mA 1.0G Hz = 50mA	156 MHz = 22mA 600 MHz = 28mA 800 MHz = 30mA 1.0G Hz = 34mA
Vcc = +3.30 VDC All values are typical an over the operating temperature.	50 MHz = 26mA 125 MHz = 30 mA 200 MHz = 34 mA	156 MHz = 40mA 600 MHz = 45mA 800 MHz = 48mA 1.0G Hz = 52mA	156 MHz = 25mA 600 MHz = 30mA 800 MHz = 32mA 1.0G Hz = 36mA

Table 1

Tape and Reel Information:

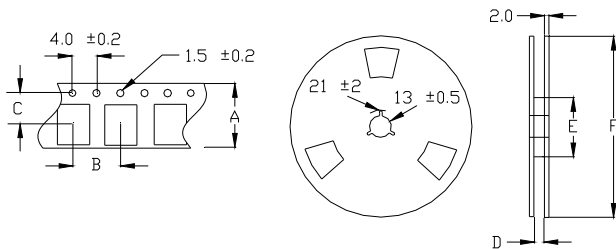

Quantity per Reel	3000
A	8.0 \pm 0.2
B	4.0 \pm 0.1
C	3.5 \pm 0.05
D	9.0 \pm 0.3
E	60 / 80
F	180 / 250

3.2 mm x 2.5 mm 6 Pads SMD TCXO or TC/VCXO Oscillator

I593 / I793 Series

Typical Applications:

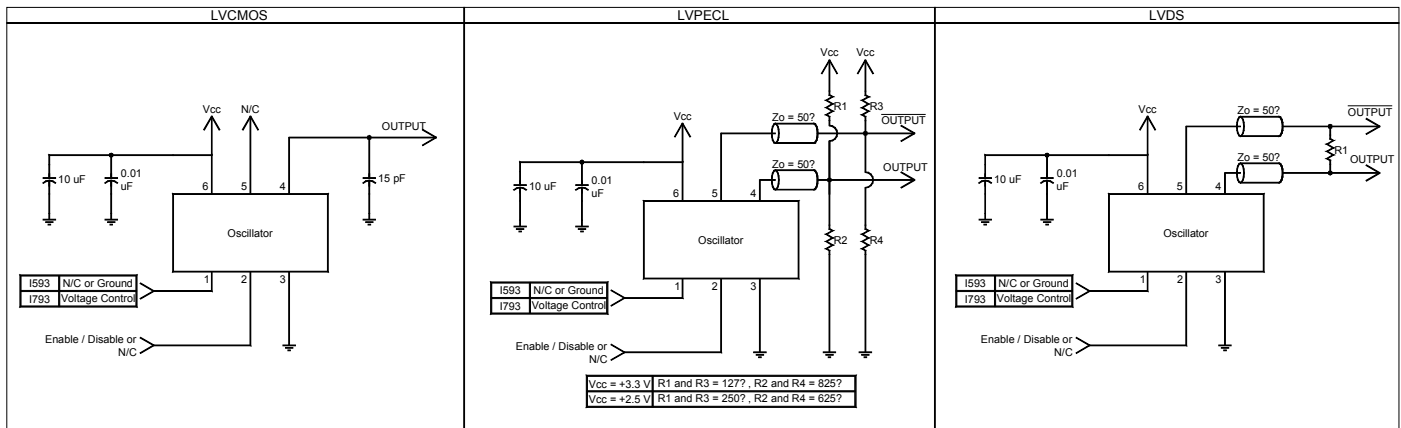

Environmental Specifications:

Thermal Shock	MIL-STD-883, Method 1011, Condition A
Moisture Resistance	MIL-STD-883, Method 1004
Mechanical Shock	MIL-STD-883, Method 2002, Condition B
Mechanical Vibration	MIL-STD-883, Method 2007, Condition A
Resistance to Soldering Heat	J-STD-020C, Table 5-2 Pb-free devices (except 2 cycles max)
Hazardous Substance	Pb-Free / RoHS / Green Compliant
Solderability	JESD22-B102-D Method 2 (Preconditioning E)
Terminal Strength	MIL-STD-883, Method 2004, Test Condition D
Gross Leak	MIL-STD-883, Method 1014, Condition C
Fine Leak	MIL-STD-883, Method 1014, Condition A2, R1=2x10 ⁻⁸ atm cc/s
Solvent Resistance	MIL-STD-202, Method 215

Package Information:

MSL = N.A. (package does not contain plastic; storage life is unlimited under normal room conditions.)
Termination = e4 (Au over Ni over W base metallization)

Pb Free Solder Reflow Profile:

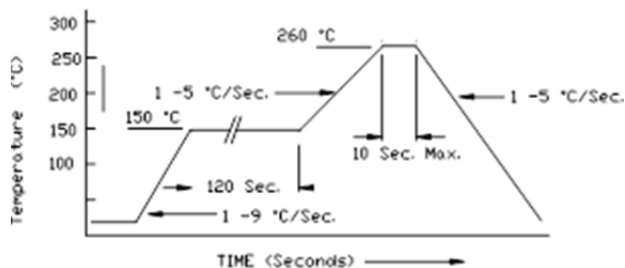

Marking:

Line 1: I - Date Code (yyww)
Line 2: Frequency

Units are backward compatible with 240°C reflow process.

PROPRIETARY AND CONFIDENTIAL

THIS DOCUMENT CONTAINS PROPRIETARY INFORMATION, AND SUCH INFORMATION MAY NOT BE DISCLOSED TO OTHERS FOR ANY PURPOSE NOR USED FOR MANUFACTURING PURPOSES WITHOUT WRITTEN PERMISSION FROM ILSI America.