



TAI-SAW TECHNOLOGY CO., LTD.

No. 3, Industrial 2nd Rd., Ping-Chen Industrial District,
Taoyuan, 324, Taiwan, R.O.C.

TEL: 886-3-4690038 FAX: 886-3-4697532

E-mail: tstsales@mail.taisaw.com Web: www.taisaw.com

Product Specifications Approval Sheet

Product Name: SAW Tx Filter 782 MHz LTE Band 13 SMD 1.1x0.9 mm (BW=10 MHz)

TST Parts No.: TA1813B (This part is compliant by AEC-Q200)

Customer Part No.: _____

Customer signature required
Company: _____
Division: _____
Approved by : _____
Date: _____

Checked by: _____ Hayley Chou *Hayley Chou*

Approved by: _____ Andy Yu *Andy Yu*

Date: _____ 2018/07/23

1. Customer signed back is required before TST can proceed with sample build and receive orders.
2. Orders received without customer signed back will be regarded as agreement on the specifications.
3. Any specifications changes must be approved upon by both parties and a new revision of specifications shall be released to reflect the changes



TAI-SAW TECHNOLOGY CO., LTD.

No. 3, Industrial 2nd Rd., Ping-Chen Industrial District,
Taoyuan, 324, Taiwan, R.O.C.

TEL: 886-3-4690038 FAX: 886-3-4697532

E-mail: tstsales@mail.taisaw.com Web: www.taisaw.com

SAW Filter 782 MHz

MODEL NO.: TA1813B

REV. No.: 1.0

A. MAXIMUM RATING:

1. Maximum Input Power: 15 dBm
2. DC voltage: 3 V
3. Operating Temperature: -40 °C to +85 °C
4. Storage Temperature: -40 °C to +85 °C
5. Moisture Sensitivity Level: Level 1 (MSL 1)
6. ESD: 100 V(MM), 200 V(HBM)

RoHS Compliant

Lead-free soldering

Electrostatic Sensitive Device (ESD)

B. ELECTRICAL CHARACTERISTICS:

Terminating source impedance: $Z_s = 50 \Omega$ (Single-ended)

Terminating load impedance: $Z_L = 50 \Omega$ (Single-ended)

Parameters Description	Unit	Min.	Typ.	Max.
Center Frequency Fc	MHz	-	782	-
Insertion Loss (777~787 MHz) IL	dB	-	1.5	2.3
Amplitude Ripple (777~787 MHz)	dB _{p-p}	-	0.5	1.1
VSWR (777~787 MHz)	-	-	1.7	2.1
Attenuation (Reference level from 0 dB)				
DC ~ 716 MHz	dB	45	59	-
716 ~ 728 MHz	dB	45	57	-
728 ~ 746 MHz	dB	45	57	-
746 ~ 756 MHz	dB	44	56	-
808 ~ 818 MHz	dB	23	31	-
869 ~ 894 MHz	dB	40	55	-
1554 ~ 1565 MHz	dB	35	48	-
1565 ~ 1585 MHz	dB	35	48	-
1597 ~ 1607 MHz	dB	35	47	-
1805 ~ 1880 MHz	dB	30	45	-
1930 ~ 1990 MHz	dB	30	44	-
2110 ~ 2170 MHz	dB	30	43	-
2331 ~ 2361 MHz	dB	29	42	-
2400 ~ 2484 MHz	dB	27	42	-
2484 ~ 3000 MHz	dB	25	39	-
3000 ~ 4000 MHz	dB	21	39	-
4000 ~ 5000 MHz	dB	15	36	-
5000 ~ 6000 MHz	dB	15	36	-

C. FREQUENCY CHARACTERISTIC:

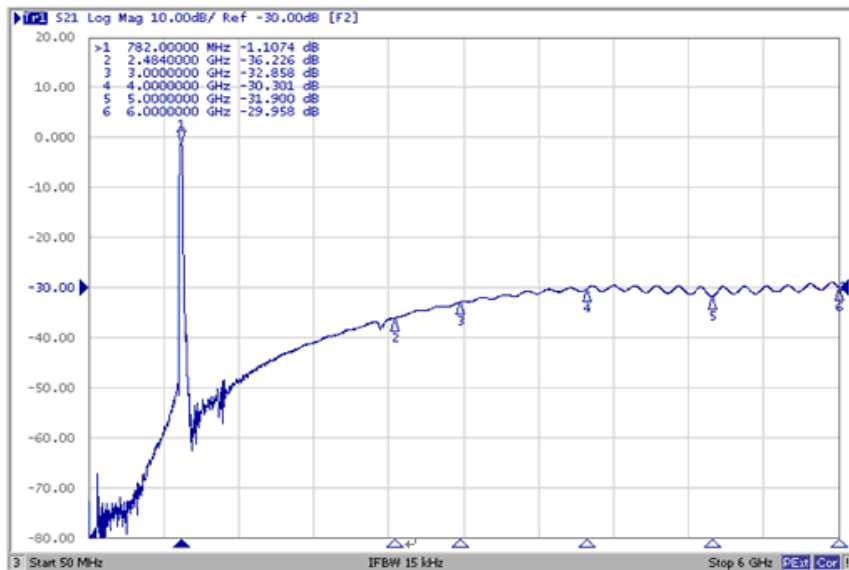
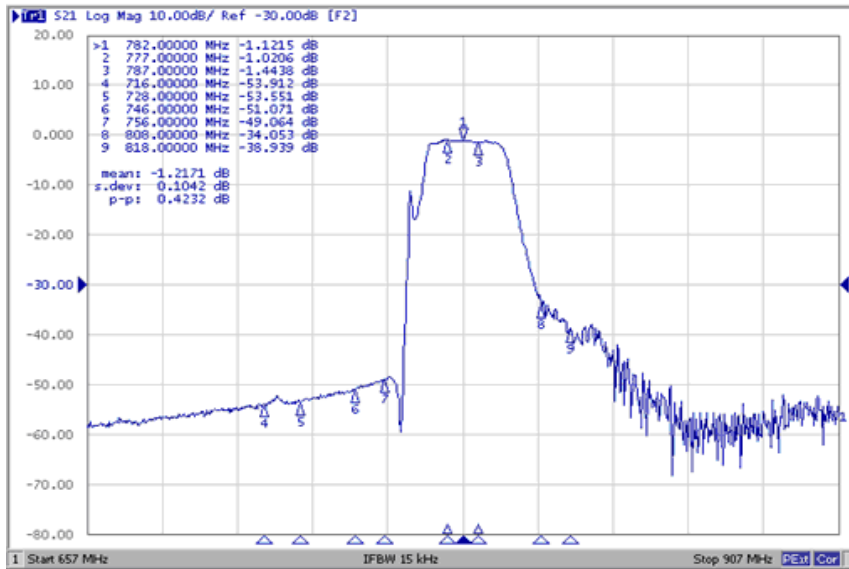
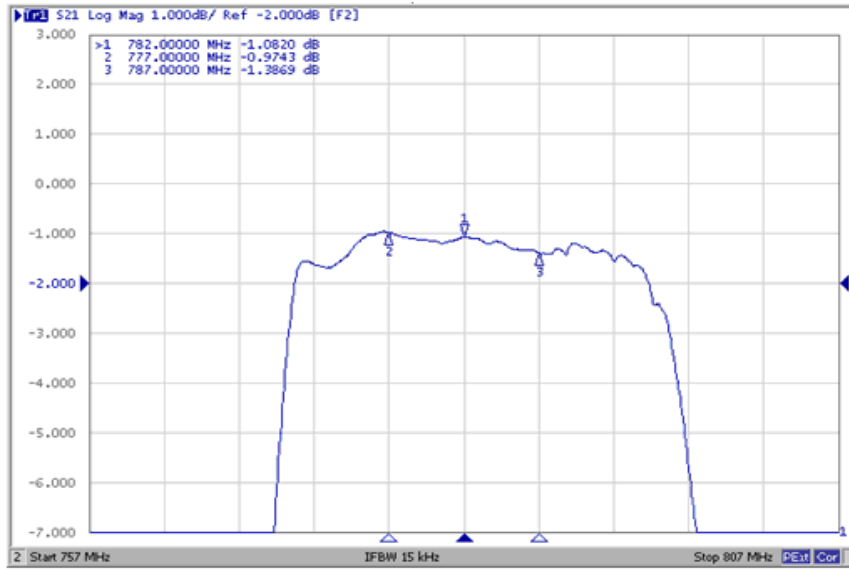

Reflection Functions:

VSWR

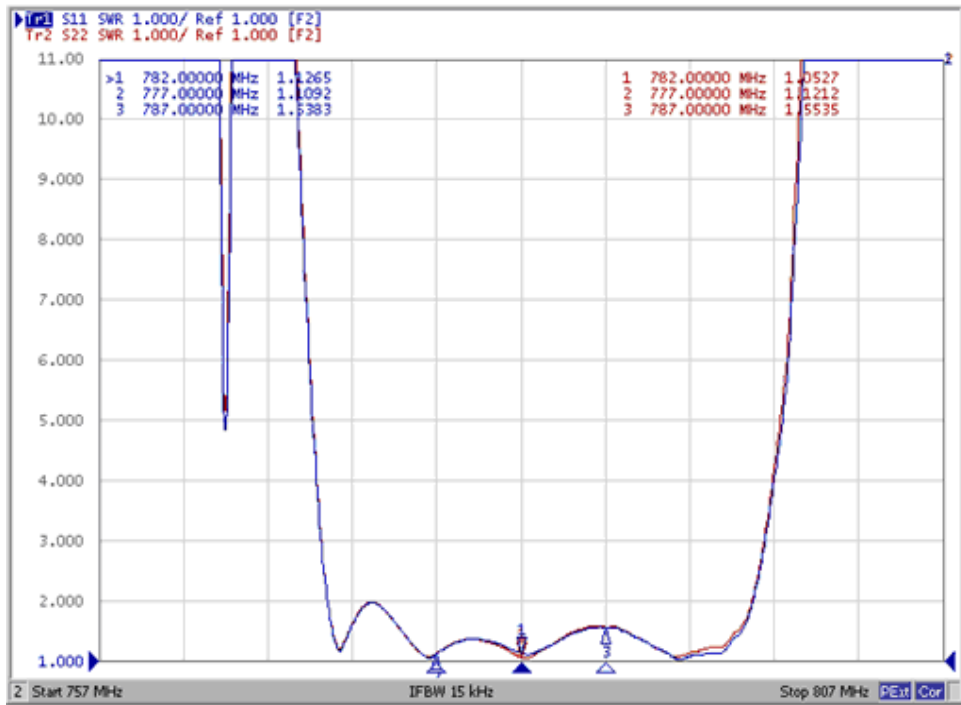

Smith Chart

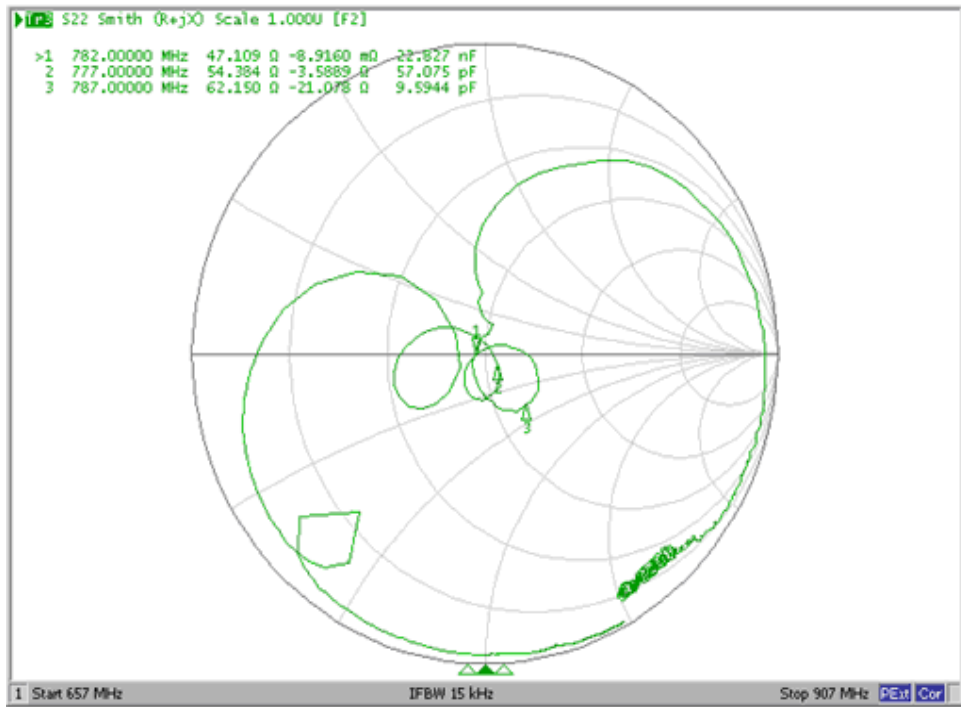
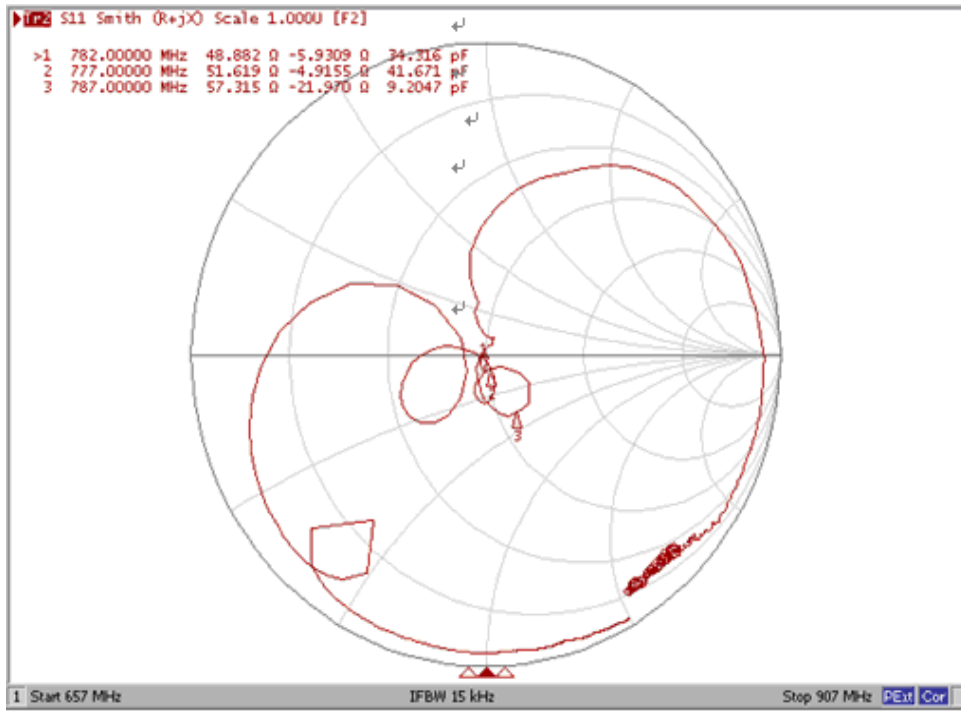

D. MEASUREMENT CIRCUIT:

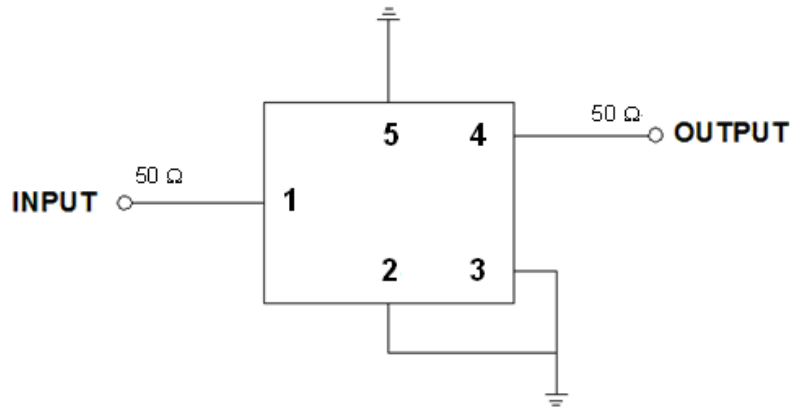

E. PCB Footprint:

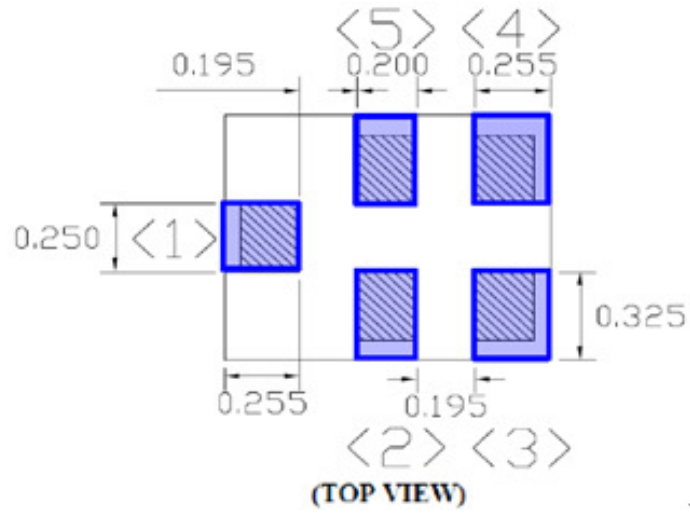

F OUTLINE DRAWING (Mass Production):

Device size: 1.1typ. x 0.9typ. x 0.5max.

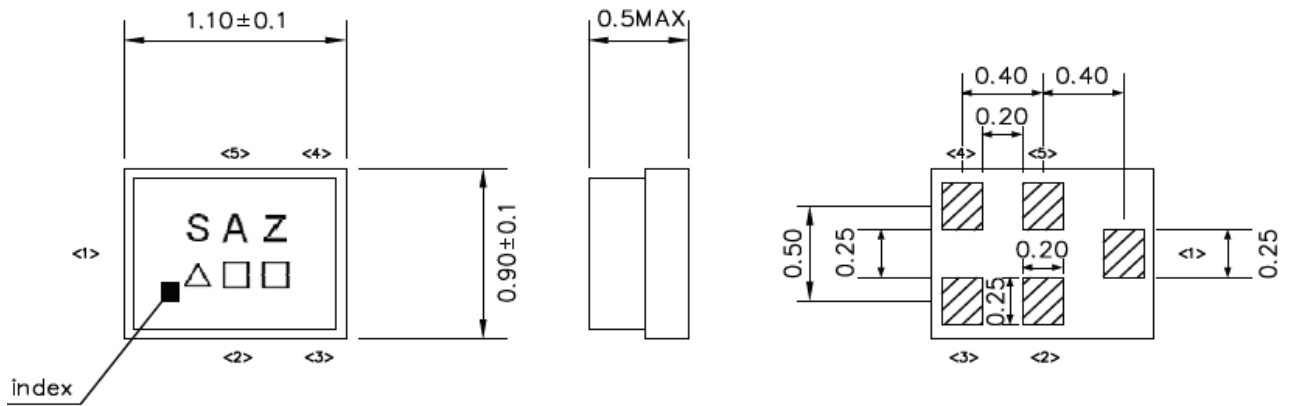

Unit : mm

Pin Configuration

Pin No.	Symbol	Function
1	IN	Unbalanced pin
2	GND	Ground
3	GND	Ground
4	OUT	Unbalanced pin
5	GND	Ground

\triangle : Date Code

\square : Lot No. (Indicated by 0~9 or A to Z and a to z, except I, O, i, o and l)

Date Code:

Year	Jan.	Feb.	Mar.	Apr.	May	Jun.	Jul.	Aug.	Sep.	Oct.	Nov.	Dec.
2017	A	B	C	D	E	F	G	H	J	K	L	M
2018	N	P	Q	R	S	T	U	V	W	X	Y	Z
2019	a	b	c	d	e	f	g	h	j	k	l	m
2020	n	p	q	r	s	t	u	v	w	x	y	z

G. PACKING: (Ref: WI-75M03)
 1. REEL DIMENSION

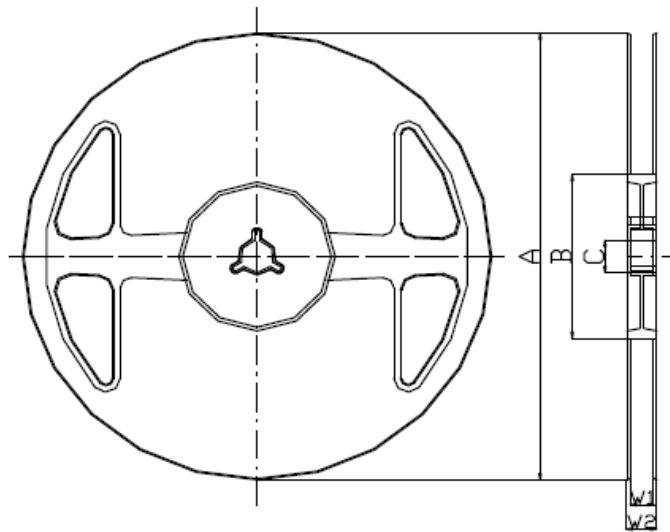

Materials of Reel

Material : Polystyrene + Carbon

Color : Black

Surface resistance (reference value) : $10^9 \Omega/\text{sq}$ Max.

Unit : mm

Code	Quantity	A	B	C	W1	W2
J	5,000 pcs	$\phi 180.0 +0.0/-1.5$	$\phi 66.0 +/-0.5$	$\phi 13.0 +/-0.2$	$9.0 +1.0/-0.0$	$11.4 +/-1.0$

2. TAPE DIMENSION

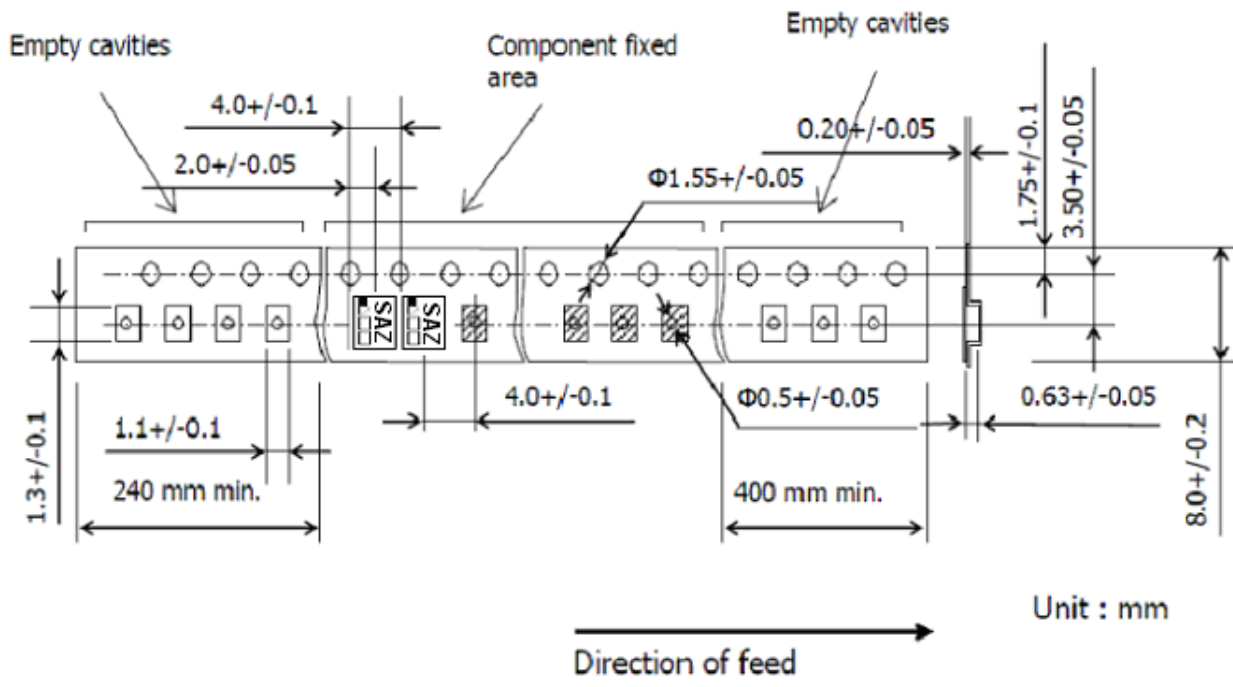

H. Recommended Reflow Profile:

1. Preheating shall be fixed at 150~180°C for 60~90 seconds.
2. Ascending time to preheating temperature 150°C shall be 30 seconds min.
3. Heating shall be fixed at 220°C for 50~80 seconds and at 260°C +0/-5°C peak (20~40sec).
4. Time: 2 times.

