

# 32-Bit

Microcontroller

# TC1791

32-Bit Single-Chip Microcontroller

Data Sheet

V 1.1 2014-05

Microcontrollers

**Edition 2014-05**

**Published by  
Infineon Technologies AG  
81726 Munich, Germany**

**© 2014 Infineon Technologies AG  
All Rights Reserved.**

#### **Legal Disclaimer**

The information given in this document shall in no event be regarded as a guarantee of conditions or characteristics. With respect to any examples or hints given herein, any typical values stated herein and/or any information regarding the application of the device, Infineon Technologies hereby disclaims any and all warranties and liabilities of any kind, including without limitation, warranties of non-infringement of intellectual property rights of any third party.

#### **Information**

For further information on technology, delivery terms and conditions and prices, please contact the nearest Infineon Technologies Office ([www.infineon.com](http://www.infineon.com)).

#### **Warnings**

Due to technical requirements, components may contain dangerous substances. For information on the types in question, please contact the nearest Infineon Technologies Office.

Infineon Technologies components may be used in life-support devices or systems only with the express written approval of Infineon Technologies, if a failure of such components can reasonably be expected to cause the failure of that life-support device or system or to affect the safety or effectiveness of that device or system. Life support devices or systems are intended to be implanted in the human body or to support and/or maintain and sustain and/or protect human life. If they fail, it is reasonable to assume that the health of the user or other persons may be endangered.

# 32-Bit

Microcontroller

# TC1791

32-Bit Single-Chip Microcontroller

Data Sheet

V 1.1 2014-05

## Table of Contents

<b>1</b>	<b>Summary of Features</b> .....	1-1
<b>2</b>	<b>System Overview of the TC1791</b> .....	2-13
2.1	Block Diagram .....	2-14
<b>3</b>	<b>Pinning</b> .....	3-19
3.1	TC1791 Pin Configuration .....	3-20
<b>4</b>	<b>Identification Registers</b> .....	4-67
<b>5</b>	<b>Electrical Parameters</b> .....	5-70
5.1	General Parameters .....	5-70
5.1.1	Parameter Interpretation .....	5-70
5.1.2	Pad Driver and Pad Classes Summary .....	5-71
5.1.3	Absolute Maximum Ratings .....	5-72
5.1.4	Pin Reliability in Overload .....	5-73
5.1.5	Operating Conditions .....	5-75
5.1.5.1	Extended Range Operating Conditions .....	5-81
5.2	DC Parameters .....	5-83
5.2.1	Input/Output Pins .....	5-83
5.2.2	Analog to Digital Converters (ADCx) .....	5-99
5.2.3	Fast Analog to Digital Converter (FADC) .....	5-104
5.2.4	Oscillator Pins .....	5-108
5.2.5	Temperature Sensor .....	5-109
5.2.6	Power Supply Current .....	5-110
5.2.6.1	Calculating the 1.3 V Current Consumption .....	5-113
5.3	AC Parameters .....	5-115
5.3.1	Testing Waveforms .....	5-115
5.3.2	Power Sequencing .....	5-116
5.3.3	Power, Pad and Reset Timing .....	5-118
5.3.4	Phase Locked Loop (PLL) .....	5-120
5.3.5	ERAY Phase Locked Loop (ERAY_PLL) .....	5-123
5.3.6	JTAG Interface Timing .....	5-124
5.3.7	DAP Interface Timing .....	5-126
5.3.8	Micro Link Interface (MLI) Timing .....	5-127
5.3.9	Micro Second Channel (MSC) Interface Timing .....	5-130
5.3.10	SSC Master/Slave Mode Timing .....	5-132
5.3.11	ERAY Interface Timing .....	5-135
5.4	Flash Memory Parameters .....	5-136
5.5	Package and Reliability .....	5-139
5.5.1	Package Parameters .....	5-139
5.5.2	Package Outline .....	5-140

---

5.5.3	Quality Declarations .....	5-140
6	<b>History</b> .....	6-1





## 1 Summary of Features

The **SAK-TC1791F-512F240EL / SAK-TC1791F-512F240EP** has the following features:

- High-performance 32-bit super-scalar TriCore V1.6 CPU with 6-stage pipeline
  - Superior real-time performance
  - Strong bit handling
  - Fully integrated DSP capabilities
  - Multiply-accumulate unit able to sustain 2 MAC operations per cycle
  - Fully pipelined Floating point unit (FPU)
  - 240 MHz operation at full temperature range
- 32-bit Peripheral Control Processor with single cycle instruction (PCP2)
  - 16 Kbyte Parameter Memory (PRAM)
  - 32 Kbyte Code Memory (CMEM)
  - 200 MHz operation at full temperature range
- Multiple on-chip memories
  - 4 Mbyte Program Flash Memory (PFLASH) with ECC
  - 192 Kbyte Data Flash Memory (DFLASH) usable for EEPROM emulation
  - 2 x 8 Kbyte Key Flash
  - 128 Kbyte Data Scratch-Pad RAM (DSPR)
  - 16 Kbyte Instruction Cache (ICACHE)
  - 32 Kbyte Instruction Scratch-Pad RAM (PSPR)
  - 16 Kbyte Data Cache (DACHE)
  - 128 Kbyte Memory (SRAM)
  - 16 Kbyte BootROM (BROM)
- 16-Channel DMA Controller
- 8-Channel Safe DMA (SDMA) Controller
- Sophisticated interrupt system with  $2 \times 255$  hardware priority arbitration levels serviced by CPU or PCP2
- High performing on-chip bus structure
  - 64-bit Cross Bar Interconnect between CPU, Flash and Data Memory
  - 32-bit System Peripheral Bus (SPB) for on-chip peripheral and functional units
  - One bus bridge (SFI Bridge)
- Versatile On-chip Peripheral Units
  - Two Asynchronous/Synchronous Serial Channels (ASC) with baud rate generator, parity, framing and overrun error detection
  - Four High-Speed Synchronous Serial Channels (SSC) with programmable data length and shift direction
  - Four SSC Guardian (SSCG) modules, one for each SSC
  - Two serial Micro Second Bus interfaces (MSC) for serial port expansion to external power devices
  - Two High-Speed Micro Link interfaces (MLI) for serial inter-processor communication



---

**Summary of Features**

- One MultiCAN Module with 4 CAN nodes and 128 free assignable message objects for high efficiency data handling via FIFO buffering and gateway data transfer (one CAN node supports TTCAN functionality)
- One FlexRay™ module with 2 channels (E-Ray).
- Two General Purpose Timer Array Modules (GPTA) with additional Local Timer Cell Array (LTCA2) providing a powerful set of digital signal filtering and timer functionality to realize autonomous and complex Input/Output management
- Two Capture / Compare 6 modules
- Two General Purpose 12 Timer Units (GPT120 and GPT121)
- 48 analog input lines for ADC
  - 4 independent kernels (ADC0, ADC1, and ADC2)
  - Analog supply voltage range from 3.3 V to 5 V (single supply)
- 4 different FADC input channels
  - channels with impedance control and overlaid with ADC1 inputs
  - Extreme fast conversion, 21 cycles of  $f_{FADC}$  clock
  - 10-bit A/D conversion (higher resolution can be achieved by averaging of consecutive conversions in digital data reduction filter)
- 8 digital input lines for SENT
  - communication according to the SENT specification J2716 FEB2008
- 128 digital general purpose I/O lines (GPIO)
- Digital I/O ports with 3.3 V capability
- On-chip debug support for OCDS Level 1 (CPU, PCP, DMA, On Chip Buses)
- Dedicated Emulation Device chip available (TC1791ED)
  - multi-core debugging, real time tracing, and calibration
  - four/five wire JTAG (IEEE 1149.1) or two wire DAP (Device Access Port) interface
- Power Management System
- Clock Generation Unit with PLL and PLL\_ERAY
- Flexible CRC Engine (FCE)
  - IEEE 802.3 CRC32 ethernet polynomial: 0x82608EDB (CRC kernel 0)
  - CRC32C Castagnoli: 0xD419CC15 (CRC kernel 1)

The **SAK-TC1791F-512F200EL / SAK-TC1791F-512F200EP** has the following features:

- High-performance 32-bit super-scalar TriCore V1.6 CPU with 6-stage pipeline
  - Superior real-time performance
  - Strong bit handling
  - Fully integrated DSP capabilities
  - Multiply-accumulate unit able to sustain 2 MAC operations per cycle
  - Fully pipelined Floating point unit (FPU)
  - 200 MHz operation at full temperature range
- 32-bit Peripheral Control Processor with single cycle instruction (PCP2)
  - 16 Kbyte Parameter Memory (PRAM)
  - 32 Kbyte Code Memory (CMEM)

---

**Summary of Features**

- 200 MHz operation at full temperature range
- Multiple on-chip memories
  - 4 Mbyte Program Flash Memory (PFLASH) with ECC
  - 192 Kbyte Data Flash Memory (DFLASH) usable for EEPROM emulation
  - 2 x 8 Kbyte Key Flash
  - 128 Kbyte Data Scratch-Pad RAM (DSPR)
  - 16 Kbyte Instruction Cache (ICACHE)
  - 32 Kbyte Instruction Scratch-Pad RAM (PSPR)
  - 16 Kbyte Data Cache (DACHE)
  - 128 Kbyte Memory (SRAM)
  - 16 Kbyte BootROM (BROM)
- 16-Channel DMA Controller
- 8-Channel Safe DMA (SDMA) Controller
- Sophisticated interrupt system with  $2 \times 255$  hardware priority arbitration levels serviced by CPU or PCP2
- High performing on-chip bus structure
  - 64-bit Cross Bar Interconnect between CPU, Flash and Data Memory
  - 32-bit System Peripheral Bus (SPB) for on-chip peripheral and functional units
  - One bus bridge (SFI Bridge)
- Versatile On-chip Peripheral Units
  - Two Asynchronous/Synchronous Serial Channels (ASC) with baud rate generator, parity, framing and overrun error detection
  - Four High-Speed Synchronous Serial Channels (SSC) with programmable data length and shift direction
  - Four SSC Guardian (SSCG) modules, one for each SSC
  - Two serial Micro Second Bus interfaces (MSC) for serial port expansion to external power devices
  - Two High-Speed Micro Link interfaces (MLI) for serial inter-processor communication
  - One MultiCAN Module with 4 CAN nodes and 128 free assignable message objects for high efficiency data handling via FIFO buffering and gateway data transfer (one CAN node supports TTCAN functionality)
  - One FlexRay™ module with 2 channels (E-Ray).
  - Two General Purpose Timer Array Modules (GPTA) with additional Local Timer Cell Array (LTCA2) providing a powerful set of digital signal filtering and timer functionality to realize autonomous and complex Input/Output management
  - Two Capture / Compare 6 modules
  - Two General Purpose 12 Timer Units (GPT120 and GPT121)
- 44 analog input lines for ADC
  - 4 independent kernels (ADC0, ADC1, and ADC2)
  - Analog supply voltage range from 3.3 V to 5 V (single supply)
- 4 different FADC input channels
  - channels with impedance control and overlaid with ADC1 inputs

---

**Summary of Features**

- Extreme fast conversion, 21 cycles of  $f_{FADC}$  clock
- 10-bit A/D conversion (higher resolution can be achieved by averaging of consecutive conversions in digital data reduction filter)
- 8 digital input lines for SENT
  - communication according to the SENT specification J2716 FEB2008
- 128 digital general purpose I/O lines (GPIO)
- Digital I/O ports with 3.3 V capability
- On-chip debug support for OCDS Level 1 (CPU, PCP, DMA, On Chip Buses)
- Dedicated Emulation Device chip available (TC1791ED)
  - multi-core debugging, real time tracing, and calibration
  - four/five wire JTAG (IEEE 1149.1) or two wire DAP (Device Access Port) interface
- Power Management System
- Clock Generation Unit with PLL and PLL\_ERAY
- Flexible CRC Engine (FCE)
  - IEEE 802.3 CRC32 ethernet polynomial: 0x82608EDB (CRC kernel 0)
  - CRC32C Castagnoli: 0xD419CC15 (CRC kernel 1)

The **SAK-TC1791F-384F200EL / SAK-TC1791F-384F200EP** has the following features:

- High-performance 32-bit super-scalar TriCore V1.6 CPU with 6-stage pipeline
  - Superior real-time performance
  - Strong bit handling
  - Fully integrated DSP capabilities
  - Multiply-accumulate unit able to sustain 2 MAC operations per cycle
  - Fully pipelined Floating point unit (FPU)
  - 200 MHz operation at full temperature range
- 32-bit Peripheral Control Processor with single cycle instruction (PCP2)
  - 16 Kbyte Parameter Memory (PRAM)
  - 32 Kbyte Code Memory (CMEM)
  - 200 MHz operation at full temperature range
- Multiple on-chip memories
  - 3 Mbyte Program Flash Memory (PFLASH) with ECC
  - 192 Kbyte Data Flash Memory (DFLASH) usable for EEPROM emulation
  - 2 x 8 Kbyte Key Flash
  - 128 Kbyte Data Scratch-Pad RAM (DSPR)
  - 16 Kbyte Instruction Cache (ICACHE)
  - 32 Kbyte Instruction Scratch-Pad RAM (PSPR)
  - 16 Kbyte Data Cache (DACHE)
  - 128 Kbyte Memory (SRAM)
  - 16 Kbyte BootROM (BROM)
- 16-Channel DMA Controller
- 8-Channel Safe DMA (SDMA) Controller

---

## Summary of Features

- Sophisticated interrupt system with  $2 \times 255$  hardware priority arbitration levels serviced by CPU or PCP2
- High performing on-chip bus structure
  - 64-bit Cross Bar Interconnect between CPU, Flash and Data Memory
  - 32-bit System Peripheral Bus (SPB) for on-chip peripheral and functional units
  - One bus bridge (SFI Bridge)
- Versatile On-chip Peripheral Units
  - Two Asynchronous/Synchronous Serial Channels (ASC) with baud rate generator, parity, framing and overrun error detection
  - Four High-Speed Synchronous Serial Channels (SSC) with programmable data length and shift direction
  - Four SSC Guardian (SSCG) modules, one for each SSC
  - Two serial Micro Second Bus interfaces (MSC) for serial port expansion to external power devices
  - Two High-Speed Micro Link interfaces (MLI) for serial inter-processor communication
  - One MultiCAN Module with 4 CAN nodes and 128 free assignable message objects for high efficiency data handling via FIFO buffering and gateway data transfer (one CAN node supports TTCAN functionality)
  - One FlexRay™ module with 2 channels (E-Ray).
  - Two General Purpose Timer Array Modules (GPTA) with additional Local Timer Cell Array (LTCA2) providing a powerful set of digital signal filtering and timer functionality to realize autonomous and complex Input/Output management
  - Two Capture / Compare 6 modules
  - Two General Purpose 12 Timer Units (GPT120 and GPT121)
- 44 analog input lines for ADC
  - 4 independent kernels (ADC0, ADC1, and ADC2)
  - Analog supply voltage range from 3.3 V to 5 V (single supply)
- 4 different FADC input channels
  - channels with impedance control and overlaid with ADC1 inputs
  - Extreme fast conversion, 21 cycles of  $f_{FADC}$  clock
  - 10-bit A/D conversion (higher resolution can be achieved by averaging of consecutive conversions in digital data reduction filter)
- 8 digital input lines for SENT
  - communication according to the SENT specification J2716 FEB2008
- 128 digital general purpose I/O lines (GPIO)
- Digital I/O ports with 3.3 V capability
- On-chip debug support for OCDS Level 1 (CPU, PCP, DMA, On Chip Buses)
- Dedicated Emulation Device chip available (TC1791ED)
  - multi-core debugging, real time tracing, and calibration
  - four/five wire JTAG (IEEE 1149.1) or two wire DAP (Device Access System) interface
- Power Management System
- Clock Generation Unit with PLL and PLL\_ERAY

---

**Summary of Features**

- Flexible CRC Engine (FCE)
  - IEEE 802.3 CRC32 ethernet polynomial: 0x82608EDB (CRC kernel 0)
  - CRC32C Castagnoli: 0xD419CC15 (CRC kernel 1)

The **SAK-TC1791S-512F240EP** has the following features:

- High-performance 32-bit super-scalar TriCore V1.6 CPU with 6-stage pipeline
  - Superior real-time performance
  - Strong bit handling
  - Fully integrated DSP capabilities
  - Multiply-accumulate unit able to sustain 2 MAC operations per cycle
  - Fully pipelined Floating point unit (FPU)
  - 240 MHz operation at full temperature range
- 32-bit Peripheral Control Processor with single cycle instruction (PCP2)
  - 16 Kbyte Parameter Memory (PRAM)
  - 32 Kbyte Code Memory (CMEM)
  - 200 MHz operation at full temperature range
- Multiple on-chip memories
  - 4 Mbyte Program Flash Memory (PFLASH) with ECC
  - 192 Kbyte Data Flash Memory (DFLASH) usable for EEPROM emulation
  - 2 x 8 Kbyte Key Flash
  - 128 Kbyte Data Scratch-Pad RAM (DSRP)
  - 16 Kbyte Instruction Cache (ICACHE)
  - 32 Kbyte Instruction Scratch-Pad RAM (PSPR)
  - 16 Kbyte Data Cache (DACHE)
  - 128 Kbyte Memory (SRAM)
  - 16 Kbyte BootROM (BROM)
- 16-Channel DMA Controller
- 8-Channel Safe DMA (SDMA) Controller
- Sophisticated interrupt system with 2 × 255 hardware priority arbitration levels serviced by CPU or PCP2
- High performing on-chip bus structure
  - 64-bit Cross Bar Interconnect between CPU, Flash and Data Memory
  - 32-bit System Peripheral Bus (SPB) for on-chip peripheral and functional units
  - One bus bridge (SFI Bridge)
- Versatile On-chip Peripheral Units
  - Two Asynchronous/Synchronous Serial Channels (ASC) with baud rate generator, parity, framing and overrun error detection
  - Four High-Speed Synchronous Serial Channels (SSC) with programmable data length and shift direction
  - Four SSC Guardian (SSCG) modules, one for each SSC
  - Two serial Micro Second Bus interfaces (MSC) for serial port expansion to external power devices

---

**Summary of Features**

- Two High-Speed Micro Link interfaces (MLI) for serial inter-processor communication
- One MultiCAN Module with 4 CAN nodes and 128 free assignable message objects for high efficiency data handling via FIFO buffering and gateway data transfer (one CAN node supports TTCAN functionality)
- One FlexRay™ module with 2 channels (E-Ray).
- Two General Purpose Timer Array Modules (GPTA) with additional Local Timer Cell Array (LTCA2) providing a powerful set of digital signal filtering and timer functionality to realize autonomous and complex Input/Output management
- Two Capture / Compare 6 modules
- Two General Purpose 12 Timer Units (GPT120 and GPT121)
- 48 analog input lines for ADC
  - 4 independent kernels (ADC0, ADC1, and ADC2)
  - Analog supply voltage range from 3.3 V to 5 V (single supply)
- 4 different FADC input channels
  - channels with impedance control and overlaid with ADC1 inputs
  - Extreme fast conversion, 21 cycles of  $f_{FADC}$  clock
  - 10-bit A/D conversion (higher resolution can be achieved by averaging of consecutive conversions in digital data reduction filter)
- 8 digital input lines for SENT
  - communication according to the SENT specification J2716 FEB2008
- 128 digital general purpose I/O lines (GPIO)
- Digital I/O ports with 3.3 V capability
- On-chip debug support for OCDS Level 1 (CPU, PCP, DMA, On Chip Buses)
- Dedicated Emulation Device chip available (TC1791ED)
  - multi-core debugging, real time tracing, and calibration
  - four/five wire JTAG (IEEE 1149.1) or two wire DAP (Device Access Port) interface
- Power Management System
- Clock Generation Unit with PLL and PLL\_ERAY
- Flexible CRC Engine (FCE)
  - IEEE 802.3 CRC32 ethernet polynomial: 0x82608EDB (CRC kernel 0)
  - CRC32C Castagnoli: 0xD419CC15 (CRC kernel 1)
- Secure Hardware Extension (SHE)
  - For further information please contact your Infineon representative

The **SAK-TC1791S-384F200EP** has the following features:

- High-performance 32-bit super-scalar TriCore V1.6 CPU with 6-stage pipeline
  - Superior real-time performance
  - Strong bit handling
  - Fully integrated DSP capabilities
  - Multiply-accumulate unit able to sustain 2 MAC operations per cycle
  - Fully pipelined Floating point unit (FPU)
  - 200 MHz operation at full temperature range

---

## Summary of Features

- 32-bit Peripheral Control Processor with single cycle instruction (PCP2)
  - 16 Kbyte Parameter Memory (PRAM)
  - 32 Kbyte Code Memory (CMEM)
  - 200 MHz operation at full temperature range
- Multiple on-chip memories
  - 3 Mbyte Program Flash Memory (PFLASH) with ECC
  - 192 Kbyte Data Flash Memory (DFLASH) usable for EEPROM emulation
  - 2 x 8 Kbyte Key Flash
  - 128 Kbyte Data Scratch-Pad RAM (DSRP)
  - 16 Kbyte Instruction Cache (ICACHE)
  - 32 Kbyte Instruction Scratch-Pad RAM (PSPR)
  - 16 Kbyte Data Cache (DACHE)
  - 128 Kbyte Memory (SRAM)
  - 16 Kbyte BootROM (BROM)
- 16-Channel DMA Controller
- 8-Channel Safe DMA (SDMA) Controller
- Sophisticated interrupt system with 2 × 255 hardware priority arbitration levels serviced by CPU or PCP2
- High performing on-chip bus structure
  - 64-bit Cross Bar Interconnect between CPU, Flash and Data Memory
  - 32-bit System Peripheral Bus (SPB) for on-chip peripheral and functional units
  - One bus bridge (SFI Bridge)
- Versatile On-chip Peripheral Units
  - Two Asynchronous/Synchronous Serial Channels (ASC) with baud rate generator, parity, framing and overrun error detection
  - Four High-Speed Synchronous Serial Channels (SSC) with programmable data length and shift direction
  - Four SSC Guardian (SSCG) modules, one for each SSC
  - Two serial Micro Second Bus interfaces (MSC) for serial port expansion to external power devices
  - Two High-Speed Micro Link interfaces (MLI) for serial inter-processor communication
  - One MultiCAN Module with 4 CAN nodes and 128 free assignable message objects for high efficiency data handling via FIFO buffering and gateway data transfer (one CAN node supports TTCAN functionality)
  - One FlexRay™ module with 2 channels (E-Ray).
  - Two General Purpose Timer Array Modules (GPTA) with additional Local Timer Cell Array (LTCA2) providing a powerful set of digital signal filtering and timer functionality to realize autonomous and complex Input/Output management
  - Two Capture / Compare 6 modules
  - Two General Purpose 12 Timer Units (GPT120 and GPT121)
- 44 analog input lines for ADC
  - 4 independent kernels (ADC0, ADC1, and ADC2)

---

**Summary of Features**

- Analog supply voltage range from 3.3 V to 5 V (single supply)
- 4 different FADC input channels
  - channels with impedance control and overlaid with ADC1 inputs
  - Extreme fast conversion, 21 cycles of  $f_{FADC}$  clock
  - 10-bit A/D conversion (higher resolution can be achieved by averaging of consecutive conversions in digital data reduction filter)
- 8 digital input lines for SENT
  - communication according to the SENT specification J2716 FEB2008
- 128 digital general purpose I/O lines (GPIO)
- Digital I/O ports with 3.3 V capability
- On-chip debug support for OCDS Level 1 (CPU, PCP, DMA, On Chip Buses)
- Dedicated Emulation Device chip available (TC1791ED)
  - multi-core debugging, real time tracing, and calibration
  - four/five wire JTAG (IEEE 1149.1) or two wire DAP (Device Access Port) interface
- Power Management System
- Clock Generation Unit with PLL and PLL\_ERAY
- Flexible CRC Engine (FCE)
  - IEEE 802.3 CRC32 ethernet polynomial: 0x82608EDB (CRC kernel 0)
  - CRC32C Castagnoli: 0xD419CC15 (CRC kernel 1)
- Secure Hardware Extension (SHE)
  - For further information please contact your Infineon representative

The **SAK-TC1791N-384F200EP** has the following features:

- High-performance 32-bit super-scalar TriCore V1.6 CPU with 6-stage pipeline
  - Superior real-time performance
  - Strong bit handling
  - Fully integrated DSP capabilities
  - Multiply-accumulate unit able to sustain 2 MAC operations per cycle
  - Fully pipelined Floating point unit (FPU)
  - 200 MHz operation at full temperature range
- 32-bit Peripheral Control Processor with single cycle instruction (PCP2)
  - 16 Kbyte Parameter Memory (PRAM)
  - 32 Kbyte Code Memory (CMEM)
  - 200 MHz operation at full temperature range
- Multiple on-chip memories
  - 3 Mbyte Program Flash Memory (PFLASH) with ECC
  - 192 Kbyte Data Flash Memory (DFLASH) usable for EEPROM emulation
  - 2 x 8 Kbyte Key Flash
  - 128 Kbyte Data Scratch-Pad RAM (DSPR)
  - 16 Kbyte Instruction Cache (ICACHE)
  - 32 Kbyte Instruction Scratch-Pad RAM (PSPR)
  - 16 Kbyte Data Cache (DACHE)
  - 128 Kbyte Memory (SRAM)



---

**Summary of Features**

- 16 Kbyte BootROM (BROM)
- 16-Channel DMA Controller
- 8-Channel Safe DMA (SDMA) Controller
- Sophisticated interrupt system with  $2 \times 255$  hardware priority arbitration levels serviced by CPU or PCP2
- High performing on-chip bus structure
  - 64-bit Cross Bar Interconnect between CPU, Flash and Data Memory
  - 32-bit System Peripheral Bus (SPB) for on-chip peripheral and functional units
  - One bus bridge (SFI Bridge)
- Versatile On-chip Peripheral Units
  - Two Asynchronous/Synchronous Serial Channels (ASC) with baud rate generator, parity, framing and overrun error detection
  - Four High-Speed Synchronous Serial Channels (SSC) with programmable data length and shift direction
  - Four SSC Guardian (SSCG) modules, one for each SSC
  - Two serial Micro Second Bus interfaces (MSC) for serial port expansion to external power devices
  - Two High-Speed Micro Link interfaces (MLI) for serial inter-processor communication
  - One MultiCAN Module with 4 CAN nodes and 128 free assignable message objects for high efficiency data handling via FIFO buffering and gateway data transfer (one CAN node supports TTCAN functionality)
  - Two General Purpose Timer Array Modules (GPTA) with additional Local Timer Cell Array (LTCA2) providing a powerful set of digital signal filtering and timer functionality to realize autonomous and complex Input/Output management
  - Two Capture / Compare 6 modules
  - Two General Purpose 12 Timer Units (GPT120 and GPT121)
- 44 analog input lines for ADC
  - 4 independent kernels (ADC0, ADC1, and ADC2)
  - Analog supply voltage range from 3.3 V to 5 V (single supply)
- 4 different FADC input channels
  - channels with impedance control and overlaid with ADC1 inputs
  - Extreme fast conversion, 21 cycles of  $f_{FADC}$  clock
  - 10-bit A/D conversion (higher resolution can be achieved by averaging of consecutive conversions in digital data reduction filter)
- 8 digital input lines for SENT
  - communication according to the SENT specification J2716 FEB2008
- 128 digital general purpose I/O lines (GPIO)
- Digital I/O ports with 3.3 V capability
- On-chip debug support for OCDS Level 1 (CPU, PCP, DMA, On Chip Buses)
- Dedicated Emulation Device chip available (TC1791ED)
  - multi-core debugging, real time tracing, and calibration
  - four/five wire JTAG (IEEE 1149.1) or two wire DAP (Device Access Port) interface

---

**Summary of Features**

- Power Management System
- Clock Generation Unit with PLL and PLL\_ERAY
- Flexible CRC Engine (FCE)
  - IEEE 802.3 CRC32 ethernet polynomial: 0x82608EDB (CRC kernel 0)
  - CRC32C Castagnoli: 0xD419CC15 (CRC kernel 1)

**Ordering Information**

The ordering code for Infineon microcontrollers provides an exact reference to the required product. This ordering code identifies:

- The derivative itself, i.e. its function set, the temperature range, and the supply voltage
- The package and the type of delivery.

For the available ordering codes for the TC1791 please refer to the “**Product Catalog Microcontrollers**”, which summarizes all available microcontroller variants.

This document describes the derivatives of the device. The **Table 1** enumerates these derivatives and summarizes the differences.

**Table 1 TC1791 Derivative Synopsis**

<b>Derivative</b>	<b>Ambient Temperature Range</b>
SAK-TC1791F-512F240EL	$T_A = -40^{\circ}\text{C}$ to $+125^{\circ}\text{C}$
SAK-TC1791F-512F240EP	$T_A = -40^{\circ}\text{C}$ to $+125^{\circ}\text{C}$
SAK-TC1791F-512F200EL	$T_A = -40^{\circ}\text{C}$ to $+125^{\circ}\text{C}$
SAK-TC1791F-512F200EP	$T_A = -40^{\circ}\text{C}$ to $+125^{\circ}\text{C}$
SAK-TC1791F-384F200EL	$T_A = -40^{\circ}\text{C}$ to $+125^{\circ}\text{C}$
SAK-TC1791F-384F200EP	$T_A = -40^{\circ}\text{C}$ to $+125^{\circ}\text{C}$
SAK-TC1791S-512F240EP	$T_A = -40^{\circ}\text{C}$ to $+125^{\circ}\text{C}$
SAK-TC1791S-384F200EP	$T_A = -40^{\circ}\text{C}$ to $+125^{\circ}\text{C}$
SAK-TC1791N-384F200EP	$T_A = -40^{\circ}\text{C}$ to $+125^{\circ}\text{C}$

## **2 System Overview of the TC1791**

The TC1791 combines three powerful technologies within one silicon die, achieving new levels of power, speed, and economy for embedded applications:

- Reduced Instruction Set Computing (RISC) processor architecture
- Digital Signal Processing (DSP) operations and addressing modes
- On-chip memories and peripherals

DSP operations and addressing modes provide the computational power necessary to efficiently analyze complex real-world signals. The RISC load/store architecture provides high computational bandwidth with low system cost. On-chip memory and peripherals are designed to support even the most demanding high-bandwidth real-time embedded control-systems tasks.

Additional high-level features of the TC1791 include:

- Efficient memory organization: instruction and data scratch memories, caches
- Serial communication interfaces – flexible synchronous and asynchronous modes
- Peripheral Control Processor – standalone data operations and interrupt servicing
- DMA Controller – DMA operations and interrupt servicing
- General-purpose timers
- High-performance on-chip buses
- On-chip debugging and emulation facilities
- Flexible interconnections to external components
- Flexible power-management

The TC1791 is a high-performance microcontroller with TriCore CPU, program and data memories, buses, bus arbitration, an interrupt controller, a peripheral control processor and a DMA controller and several on-chip peripherals. The TC1791 is designed to meet the needs of the most demanding embedded control systems applications where the competing issues of price/performance, real-time responsiveness, computational power, data bandwidth, and power consumption are key design elements.

The TC1791 offers several versatile on-chip peripheral units such as serial controllers, timer units, and Analog-to-Digital converters. Within the TC1791, all these peripheral units are connected to the TriCore CPU/system via the Flexible Peripheral Interconnect (FPI) Bus and the Cross Bar Interconnect (SRI). Several I/O lines on the TC1791 ports are reserved for these peripheral units to communicate with the external world.

System Overview of the TC1791 Block Diagram

2.1 Block Diagram

Figure 1 shows the block diagram of the SAK-TC1791F-512F240EL / SAK-TC1791F-512F240EP / SAK-TC1791F-512F200EL / SAK-TC1791F-512F200EP.

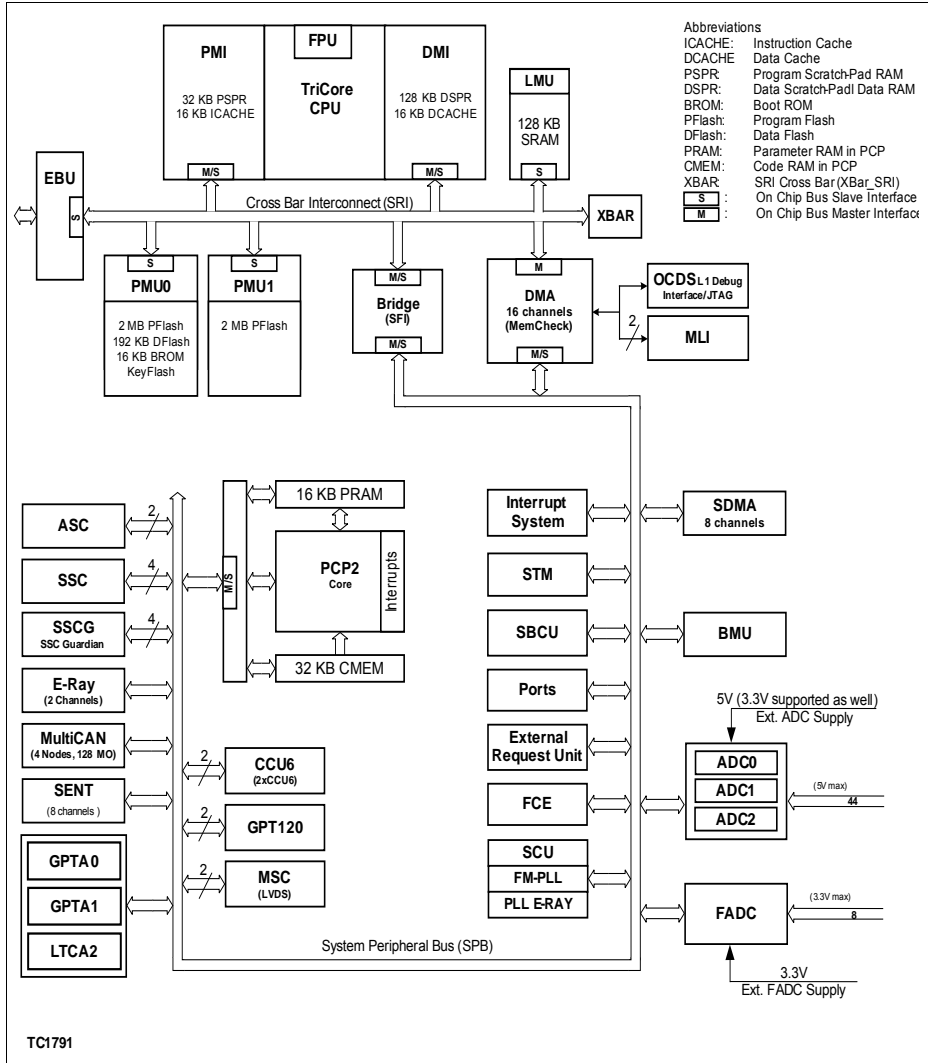

Figure 1 Block Diagram

System Overview of the TC1791 Block Diagram

Figure 2 shows the block diagram of the SAK-TC1791F-384F200EL / SAK-TC1791F-384F200EP.

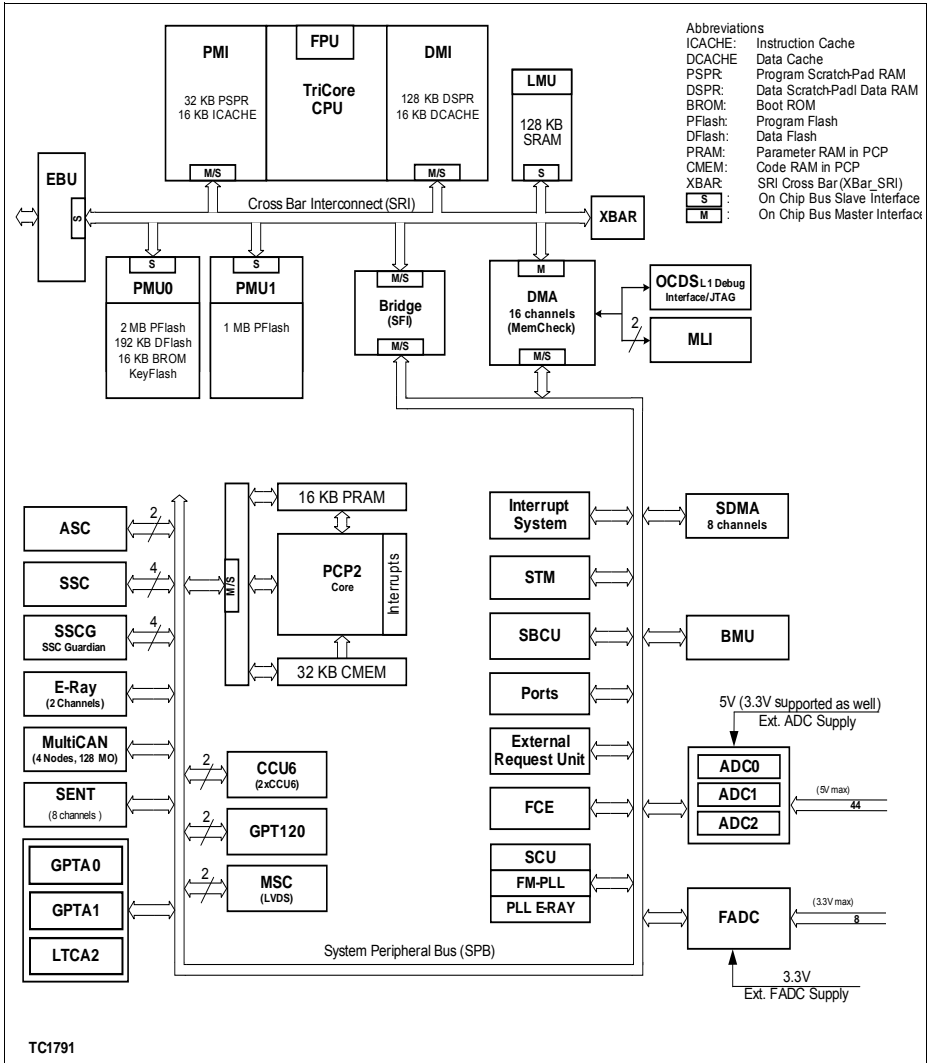

Figure 2 Block Diagram

Figure 3 shows the block diagram of the SAK-TC1791S-512F240EP.

System Overview of the TC1791 Block Diagram

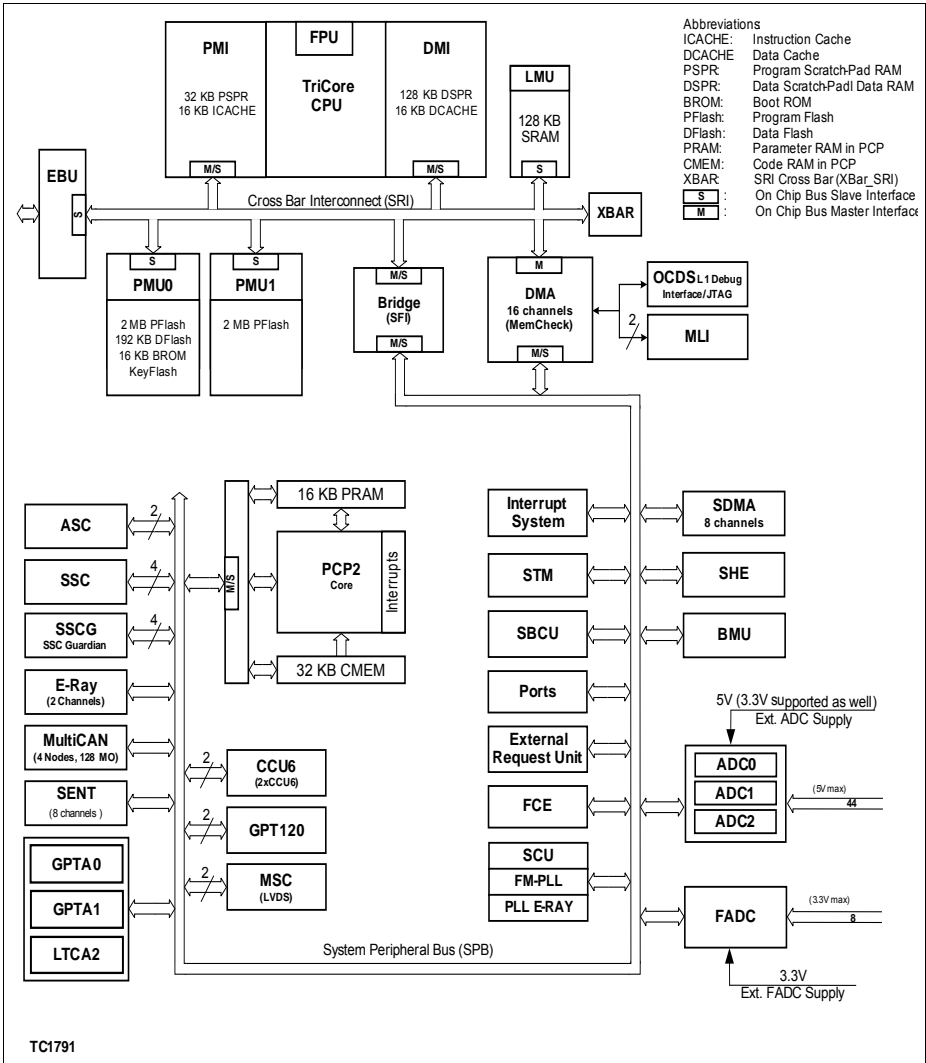

Figure 3 Block Diagram

Figure 4 shows the block diagram of the SAK-TC1791S-384F200EP.

System Overview of the TC1791 Block Diagram

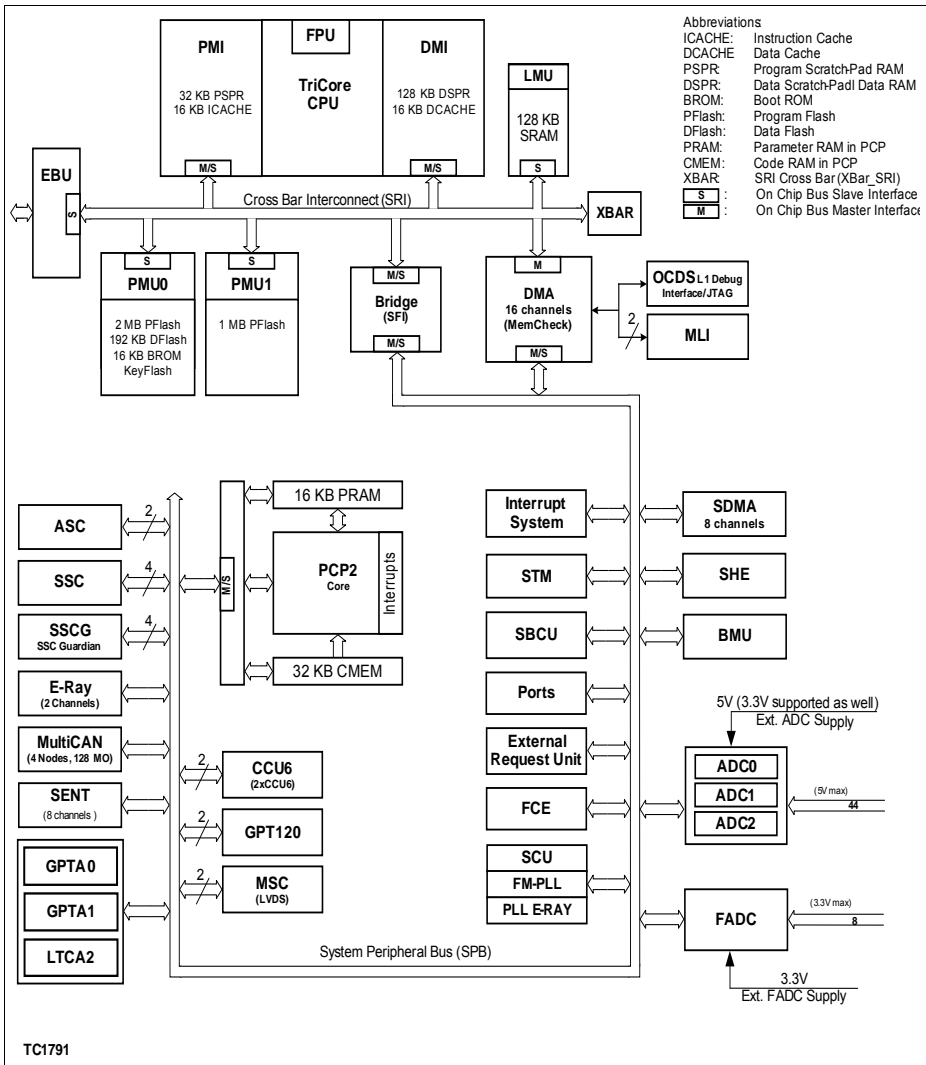

Figure 4 Block Diagram

Figure 5 shows the block diagram of the SAK-TC1791N-384F200EP.



System Overview of the TC1791 Block Diagram

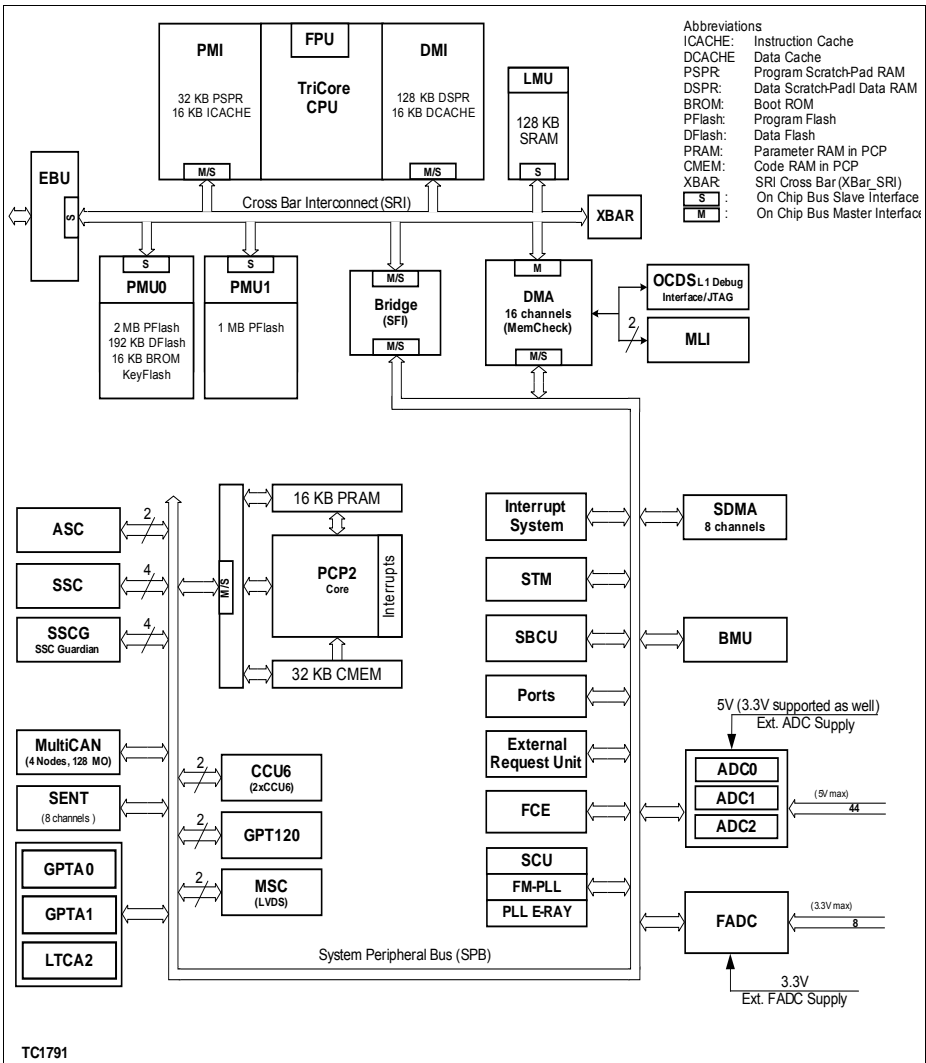

Figure 5 Block Diagram

### 3 Pinning

Figure 6 is showing the TC1791 Logic Symbol.

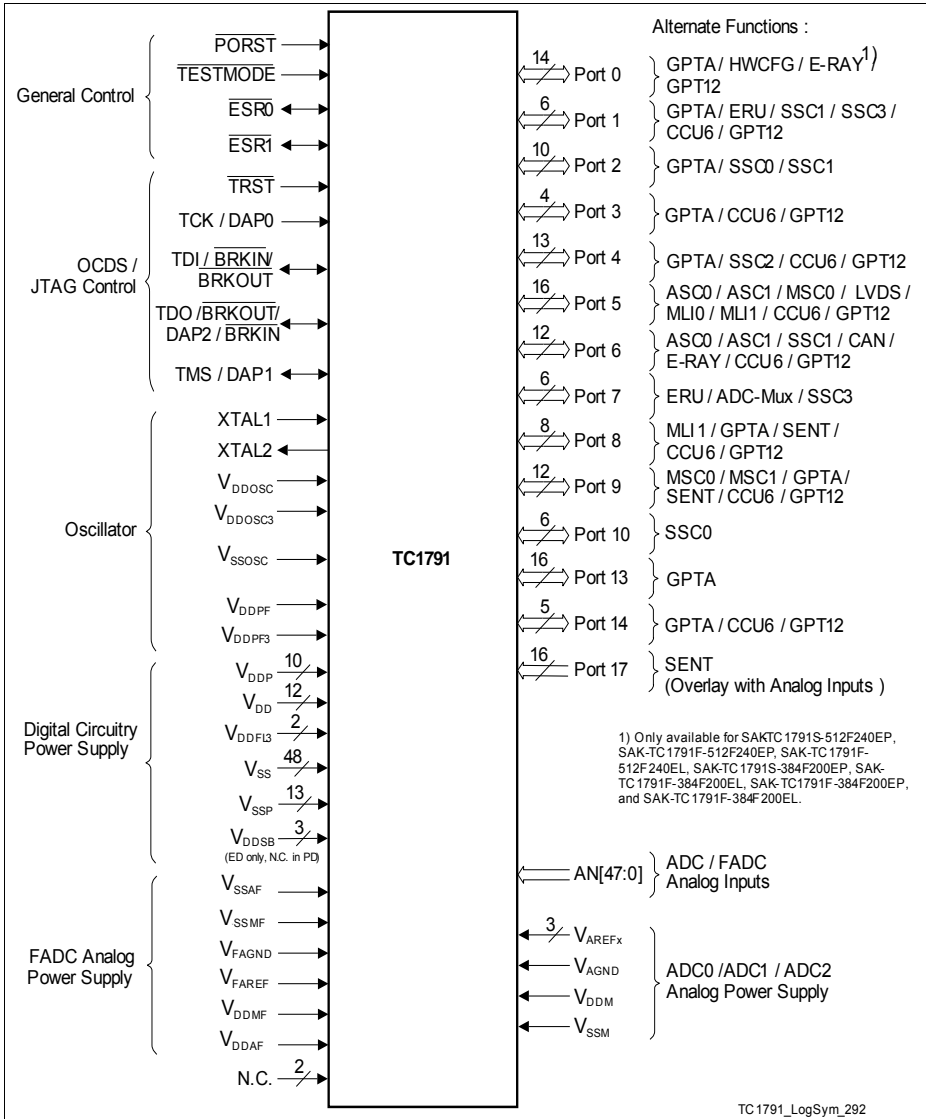

Figure 6 TC1791 Logic Symbol

Pinning TC1791 Pin Configuration

3.1 TC1791 Pin Configuration

This chapter shows the pin configuration of the TC1791 package PG-LFBGA- 292-6.

	20	19	18	17	16	15	14	13	12	11	10	9	8	7	6	5	4	3	2	1
Y	VSS	PI46	PI48	VSSP	PI05	PI00	PI03	P4.7	P4.3	VSSP	VSS MF	AN30	AN26	VA GND0	VA REF0	AN39	AN37	AN34	AN1	NC
W	VDD	VSS	PI44	VDDP	PI04	PI01	P4.10	P4.6	P4.2	VDDP	VFA GND	AN29	AN25	VA REF2	VA REF1	AN38	AN36	AN33	AN2	AN3
V	PI42	VDD																	AN4	AN44
U	PI40	PI3.15	VSS	PI02	P4.14	P4.9	P4.5	P4.1	VDD MF	VFA REF	AN28	AN24	AN33	AN31	AN7	AN2	AN5	AN55		
T	PI3.14	PI3.13	VDD	VSS	P4.12	P4.8	P4.4	P4.0	VDD AF	AN31	AN27	AN23	AN22	AN20	AN7	AN0	AN6	AN66		
R	PI3.12	PI3.11	PI3.10	VDD												AN8	AN9	VDDM	VSSM	
P	PI3.9	PI3.8	PI3.7	PI3.6								AN10	AN11	AN12	AN13					
N	PI3.5	PI3.4	PI3.3	PI3.2	VDD	VSS	VSS	VSS	VSS	VSS	VSS	VSS	VSS	VSS	AN16	AN17	AN14	AN15		
M	VDDP	VDDP	PI3.1	PI3.0	VSS	VSS	VSS	VSS	VSS	VSS	VSS	VSS	VSS	VSS	AN18	AN19	AN20	AN21		
L	VSSP	VSSP	VDD FF3	VDD FL3	VSS	VSS	VSS	VSS	VSS	VSS	VSS	VSS	VSS	VSS	NC	NC	AN22	AN23		
K	XTAL1	XTAL2	VDD FF	VDD OSC3	VSS	VSS	VSS	VSS	VSS	VSS	VSS	VSS	VSS	VSS	VDD FL3	P7.5	VDDP	VSSP		
J	VSS OSC	VDD OSC	TDI	TMS	VSS	VSS	VSS	VSS	VSS	VSS	VSS	VSS	VSS	VSS	P7.4	P7.3	P7.2	P7.1		
H	TCK	TRST	TDO	P9.14	VDD	VSS	VSS	VSS	VSS	VSS	VSS	VSS	VSS	VSS	P7.0	P1.1	P1.12	P1.0		
G	ESR1	ESR0	Test mode	P9.13	VDD	VSS	VSS	VSS	VSS	VSS	VSS	VSS	VSS	VSS	P1.9	P8.6	P1.6	P1.7		
F	P9.10	FORST	P9.5	P9.6												P8.5	P8.7	P8.4	P8.0	
E	P9.7	P9.8	P9.0	VSSP	P5.5	P3.0	P3.4	P3.12	P0.1	P0.3	P0.5	P0.7	P2.6	P8.1	VSSP	P8.2	P8.3	P6.15		
D	P9.2	P9.1	VSSP	P5.7	P5.2	P5.12	P3.10	P0.0	P0.2	P0.4	P0.6	P2.10	P2.5	P2.4	P6.7	VSSP	P6.11	P6.14		
C	P9.3	P9.4																	P6.10	P6.13
B	P5.6	VSSP	VDDP	P5.9	P5.8	P5.3	P5.13	P5.14	P0.10	P0.13	VDDP	P0.9	P2.12	P2.7	P2.3	P6.8	P6.4	VDDP	VSSP	P6.12
A	VSSP	VDDP	P5.4	P5.11	P5.10	P5.0	P5.1	P5.15	P0.11	P0.12	VSSP	P0.14	P2.14	P2.8	P2.2	P6.9	P6.6	P6.5	VDDP	NC

Figure 7 TC1791 Pinning for PG-LFBGA-292 Package

**Table 2 Pin Definitions and Functions**

Pin	Symbol	Ctrl.	Type	Function
<b>Port 0</b>				
D12	P0.0	I/O	A1+/ PU	<b>Port 0 General Purpose I/O Line 0</b>
	HWCFG0	I		<b>Hardware Configuration Input 0</b>
	OUT56	O1		<b>OUT56 Line of GPTA0</b>
	OUT56	O2		<b>OUT56 Line of GPTA1</b>
	OUT80	O3		<b>OUT80 Line of LTCA2</b>
E11	P0.1	I/O	A1/ PU	<b>Port 0 General Purpose I/O Line 1</b>
	HWCFG1	I		<b>Hardware Configuration Input 1</b>
	OUT57	O1		<b>OUT57 Line of GPTA0</b>
	OUT57	O2		<b>OUT57 Line of GPTA1</b>
	OUT81	O3		<b>OUT81 Line of LTCA2</b>
D11	P0.2	I/O	A2/ PU	<b>Port 0 General Purpose I/O Line 2</b>
	HWCFG2	I		<b>Hardware Configuration Input 2</b>
	OUT58	O1		<b>OUT58 Line of GPTA0</b>
	OUT58	O2		<b>OUT58 Line of GPTA1</b>
	OUT82	O3		<b>OUT82 Line of LTCA2</b>
E10	P0.3	I/O	A1/ PU	<b>Port 0 General Purpose I/O Line 3</b>
	HWCFG3	I		<b>Hardware Configuration Input 3</b>
	OUT59	O1		<b>OUT59 Line of GPTA0</b>
	OUT59	O2		<b>OUT59 Line of GPTA1</b>
	OUT83	O3		<b>OUT83 Line of LTCA2</b>

## PinningTC1791 Pin Configuration

**Table 2 Pin Definitions and Functions (cont'd)**

Pin	Symbol	Ctrl.	Type	Function
D10	P0.4	I/O	A1/ PU	Port 0 General Purpose I/O Line 4
	HWCFG4	I		Hardware Configuration Input 4
	OUT60	O1		OUT60 Line of GPTA0
	OUT60	O2		OUT60 Line of GPTA1
	EVT00	O3		MCDS Output Event 0 <sup>1)</sup>
E9	P0.5	I/O	A1/ PU	Port 0 General Purpose I/O Line 5
	HWCFG5	I		Hardware Configuration Input 5
	OUT61	O1		OUT61 Line of GPTA0
	OUT61	O2		OUT61 Line of GPTA1
	EVT01	O3		MCDS Output Event 1 <sup>1)</sup>
D9	P0.6	I/O	A2/ PU	Port 0 General Purpose I/O Line 6
	HWCFG6	I		Hardware Configuration Input 6
	OUT62	O1		OUT62 Line of GPTA0
	OUT62	O2		OUT62 Line of GPTA1
	EVT02	O3		MCDS Output Event 2 <sup>1)</sup>
E8	P0.7	I/O	A1/ PU	Port 0 General Purpose I/O Line 7
	HWCFG7	I		Hardware Configuration Input 7
	OUT63	O1		OUT63 Line of GPTA0
	OUT63	O2		OUT63 Line of GPTA1
	EVT03	O3		MCDS Output Event 3 <sup>1)</sup>
B9	P0.9	I/O	A1/ PU	Port 0 General Purpose I/O Line 9
	RXDA0	I		E-Ray Channel A Receive Data Input 0 <sup>2)</sup>
	Reserved	O1		-
	Reserved	O2		-
	Reserved	O3		-

## PinningTC1791 Pin Configuration

**Table 2 Pin Definitions and Functions (cont'd)**

Pin	Symbol	Ctrl.	Type	Function
B12	P0.10	I/O	A2/ PU	<b>Port 0 General Purpose I/O Line 10</b>
	TXENA	O1		<b>E-Ray Channel A transmit Data Output enable <sup>2)</sup></b>
	Reserved	O2		-
	Reserved	O3		-
A12	P0.11	I/O	A2/ PU	<b>Port 0 General Purpose I/O Line 11</b>
	T5INB	I		<b>GPT120</b>
	T5INA	I		<b>GPT121</b>
	TXENB	O1		<b>E-Ray Channel B transmit Data Output enable <sup>2)</sup></b>
	Reserved	O2		-
	Reserved	O3		-
A11	P0.12	I/O	A2/ PU	<b>Port 0 General Purpose I/O Line 12</b>
	T5EUDA	I		<b>GPT120</b>
	T5EADB	I		<b>GPT121</b>
	TXDB	O1		<b>E-Ray Channel B transmit Data Output <sup>2)</sup></b>
	Reserved	O2		-
	Reserved	O3		-
B11	P0.13	I/O	A1/ PU	<b>Port 0 General Purpose I/O Line 13</b>
	RXDB0	I		<b>E-Ray Channel B Receive Data Input 0 <sup>2)</sup></b>
	T5EADB	I		<b>GPT120</b>
	T5EUDA	I		<b>GPT121</b>
	Reserved	O1		-
	Reserved	O2		-
	Reserved	O3		-

## Pinning TC1791 Pin Configuration

**Table 2 Pin Definitions and Functions (cont'd)**

Pin	Symbol	Ctrl.	Type	Function
A9	P0.14	I/O	A2/ PU	<b>Port 0 General Purpose I/O Line 14</b>
	T6INA	I		<b>GPT120</b>
	T6INB	I		<b>GPT121</b>
	TXDA	O1		<b>E-Ray Channel A transmit Data Output <sup>2)</sup></b>
	Reserved	O2		-
	Reserved	O3		-
<b>Port 1</b>				
H1	P1.0	I/O	A2/ PU	<b>Port 1 General Purpose I/O Line 0</b>
	REQ0	I		<b>External trigger Input 0</b>
	EXTCLK1	O1		<b>External Clock Output 1</b>
	Reserved	O2		-
	Reserved	O3		-
H4	P1.1	I/O	A1/ PU	<b>Port 1 General Purpose I/O Line 1</b>
	REQ1	I		<b>External trigger Input 1</b>
	CC60INA	I		<b>CCU60</b>
	CC60INB	I		<b>CCU61</b>
	CC60	O1		<b>CCU60</b>
	Reserved	O2		-
	Reserved	O3		-
G2	P1.6	I/O	A2/ PU	<b>Port 1 General Purpose I/O Line 6</b>
	TVALID0A	O1		<b>MLI0 transmit Channel valid Output A</b>
	SLSO10	O2		<b>SSC1 Slave Select Output Line 10</b>
	COUT60	O3		<b>CCU60</b>

## Pinning TC1791 Pin Configuration

**Table 2 Pin Definitions and Functions (cont'd)**

Pin	Symbol	Ctrl.	Type	Function
G1	P1.7	I/O	A2/ PU	<b>Port 1 General Purpose I/O Line 7</b>
	CC61INB	I		<b>CCU60</b>
	CC61INA	I		<b>CCU61</b>
	TData0	O1		<b>MLI0 transmit Channel Data Output</b>
	CC61	O2		<b>CCU61</b>
	T3OUT	O3		<b>GPT120</b>
G5	P1.9	I/O	A2/ PU	<b>Port 1 General Purpose I/O Line 9</b>
	RREADY0A	O1		<b>MLI0 Receive Channel ready Output A</b>
	SLSO11	O2		<b>SSC1 Slave Select Output Line 11</b>
	OUT65	O3		<b>OUT65 Line of GPTA0</b>
H2	P1.12	I/O	A2/ PU	<b>Port 1 General Purpose I/O Line 12</b>
	EXTCLK0	O1		<b>External Clock Output 0</b>
	OUT68	O2		<b>OUT68 Line of GPTA0</b>
	OUT68	O3		<b>OUT68 Line of GPTA1</b>
<b>Port 2</b>				
A6	P2.2	I/O	A1+/ PU	<b>Port 2 General Purpose I/O Line 2</b>
	SLSO02	O1		<b>SSC0 Slave Select Output Line 2</b>
	SLSO12	O2		<b>SSC1 Slave Select Output Line 12</b>
	SLSO02 AND SLSO12	O3		<b>SSC0 &amp; SSC1 Slave Select Output Line 2 AND Slave Select Output Line 12</b>
B6	P2.3	I/O	A1+/ PU	<b>Port 2 General Purpose I/O Line 3</b>
	SLSO03	O1		<b>SSC0 Slave Select Output Line 3</b>
	SLSO13	O2		<b>SSC1 Slave Select Output Line 13</b>
	SLSO03 AND SLSO13	O3		<b>SSC0 &amp; SSC1 Slave Select Output Line 3 AND Slave Select Output Line 13</b>



## PinningTC1791 Pin Configuration

**Table 2 Pin Definitions and Functions (cont'd)**

Pin	Symbol	Ctrl.	Type	Function
D6	P2.4	I/O	A1+/ PU	<b>Port 2 General Purpose I/O Line 4</b>
	SLSO04	O1		<b>SSC0 Slave Select Output Line 4</b>
	SLSO14	O2		<b>SSC1 Slave Select Output Line 14</b>
	SLSO04 AND SLSO14	O3		<b>SSC0 &amp; SSC1 Slave Select Output Line 4 AND Slave Select Output Line 14</b>
D7	P2.5	I/O	A1+/ PU	<b>Port 2 General Purpose I/O Line 5</b>
	SLSO05	O1		<b>SSC0 Slave Select Output Line 5</b>
	SLSO15	O2		<b>SSC1 Slave Select Output Line 15</b>
	SLSO05 AND SLSO15	O3		<b>SSC0 &amp; SSC1 Slave Select Output Line 5 AND Slave Select Output Line 15</b>
E7	P2.6	I/O	A1+/ PU	<b>Port 2 General Purpose I/O Line 6</b>
	SLSO06	O1		<b>SSC0 Slave Select Output Line 6</b>
	SLSO16	O2		<b>SSC1 Slave Select Output Line 16</b>
	SLSO06 AND SLSO16	O3		<b>SSC0 &amp; SSC1 Slave Select Output Line 6 AND Slave Select Output Line 16</b>
B7	P2.7	I/O	A1+/ PU	<b>Port 2 General Purpose I/O Line 7</b>
	SLSO07	O1		<b>SSC0 Slave Select Output Line 7</b>
	SLSO17	O2		<b>SSC1 Slave Select Output Line 17</b>
	SLSO07 AND SLSO17	O3		<b>SSC0 &amp; SSC1 Slave Select Output Line 7AND Slave Select Output Line 17</b>

## Pinning TC1791 Pin Configuration

**Table 2 Pin Definitions and Functions (cont'd)**

Pin	Symbol	Ctrl.	Type	Function
A7	P2.8	I/O	A1/ PU	<b>Port 2 General Purpose I/O Line 8</b>
	IN0	I		<b>IN0 Line of GPTA0</b>
	IN0	I		<b>IN0 Line of GPTA1</b>
	IN0	I		<b>IN0 Line of LTCA2</b>
	CCPOS0A	I		<b>CCU62</b>
	T12HRB	I		<b>CCU63</b>
	T3INB	I		<b>GPT120</b>
	T3INA	I		<b>GPT121</b>
	OUT0	O1		<b>OUT0 Line of GPTA0</b>
	OUT0	O2		<b>OUT0 Line of GPTA1</b>
	OUT0	O3		<b>OUT0 Line of LTCA2</b>
D8	P2.10	I/O	A1/ PU	<b>Port 2 General Purpose I/O Line 10</b>
	IN2	I		<b>IN2 Line of GPTA0</b>
	IN2	I		<b>IN2 Line of GPTA1</b>
	IN2	I		<b>IN2 Line of LTCA2</b>
	T12HRE	I		<b>CCU60</b>
	CC61INC	I		<b>CCU60</b>
	CTRAPA	I		<b>CCU61</b>
	CTRAPB	I		<b>CCU63</b>
	CC60INC	I		<b>CCU61</b>
	OUT2	O1		<b>OUT2 Line of GPTA0</b>
	OUT2	O2		<b>OUT2 Line of GPTA1</b>
	OUT2	O3		<b>OUT2 Line of LTCA2</b>

Pinning TC1791 Pin Configuration

**Table 2 Pin Definitions and Functions (cont'd)**

Pin	Symbol	Ctrl.	Type	Function
B8	P2.12	I/O	A1/ PU	<b>Port 2 General Purpose I/O Line 12</b>
	IN4	I		<b>IN4 Line of GPTA0</b>
	IN4	I		<b>IN4 Line of GPTA1</b>
	IN4	I		<b>IN4 Line of LTCA2</b>
	T12HRB	I		<b>CCU62</b>
	CCPOS0A	I		<b>CCU63</b>
	T2INB	I		<b>GPT120</b>
	T2INA	I		<b>GPT121</b>
	OUT4	O1		<b>OUT4 Line of GPTA0</b>
	OUT4	O2		<b>OUT4 Line of GPTA1</b>
	OUT4	O3		<b>OUT4 Line of LTCA2</b>
A8	P2.14	I/O	A1/ PU	<b>Port 2 General Purpose I/O Line 14</b>
	IN6	I		<b>IN6 Line of GPTA0</b>
	IN6	I		<b>IN6 Line of GPTA1</b>
	IN6	I		<b>IN6 Line of LTCA2</b>
	CCPOS0A	I		<b>CCU60</b>
	T12HRB	I		<b>CCU61</b>
	T3INA	I		<b>GPT120</b>
	T3INB	I		<b>GPT121</b>
	OUT6	O1		<b>OUT6 Line of GPTA0</b>
	OUT6	O2		<b>OUT6 Line of GPTA1</b>
	OUT6	O3		<b>OUT6 Line of LTCA2</b>
<b>Port 3</b>				

## Pinning TC1791 Pin Configuration

**Table 2 Pin Definitions and Functions (cont'd)**

Pin	Symbol	Ctrl.	Type	Function
E14	P3.0	I/O	A1/ PU	<b>Port 3 General Purpose I/O Line 0</b>
	IN8	I		<b>IN8 Line of GPTA0</b>
	IN8	I		<b>IN8 Line of GPTA1</b>
	IN8	I		<b>IN8 Line of LTCA2</b>
	CTRAPA	I		<b>CCU62</b>
	CTRAPB	I		<b>CCU61</b>
	CC60INC	I		<b>CCU62</b>
	T12HRE	I		<b>CCU63</b>
	CC61INC	I		<b>CCU63</b>
	T5INA	I		<b>GPT120</b>
	T5INB	I		<b>GPT121</b>
	OUT8	O1		<b>OUT8 Line of GPTA0</b>
	OUT8	O2		<b>OUT8 Line of GPTA1</b>
OUT8	O3	<b>OUT8 Line of LTCA2</b>		
E13	P3.4	I/O	A1/ PU	<b>Port 3 General Purpose I/O Line 4</b>
	IN12	I		<b>IN12 Line of GPTA0</b>
	IN12	I		<b>IN12 Line of GPTA1</b>
	IN12	I		<b>IN12 Line of LTCA2</b>
	T12HRE	I		<b>CCU62</b>
	CC61INC	I		<b>CCU62</b>
	CTRAPA	I		<b>CCU63</b>
	CTRAPB	I		<b>CCU60</b>
	CC60INC	I		<b>CCU63</b>
	OUT12	O1		<b>OUT12 Line of GPTA0</b>
	OUT12	O2		<b>OUT12 Line of GPTA1</b>
	OUT12	O3		<b>OUT12 Line of LTCA2</b>

Pinning TC1791 Pin Configuration

**Table 2 Pin Definitions and Functions (cont'd)**

Pin	Symbol	Ctrl.	Type	Function
D13	P3.10	I/O	A1+/ PU	<b>Port 3 General Purpose I/O Line 10</b>
	IN18	I		<b>IN18 Line of GPTA0</b>
	IN18	I		<b>IN18 Line of GPTA1</b>
	IN18	I		<b>IN18 Line of LTCA2</b>
	CCPOS1A	I		<b>CCU62</b>
	T13HRB	I		<b>CCU63</b>
	T3EUDB	I		<b>GPT120</b>
	T3EUDA	I		<b>GPT121</b>
	OUT18	O1		<b>OUT18 Line of GPTA0</b>
	OUT18	O2		<b>OUT18 Line of GPTA1</b>
	OUT18	O3		<b>OUT18 Line of LTCA2</b>
E12	P3.12	I/O	A1/ PU	<b>Port 3 General Purpose I/O Line 12</b>
	IN20	I		<b>IN20 Line of GPTA0</b>
	IN20	I		<b>IN20 Line of GPTA1</b>
	IN20	I		<b>IN20 Line of LTCA2</b>
	CCPOS2A	I		<b>CCU62</b>
	T12HRC	I		<b>CCU63</b>
	T13HRC	I		<b>CCU63</b>
	T4INB	I		<b>GPT120</b>
	T4INA	I		<b>GPT121</b>
	OUT20	O1		<b>OUT20 Line of GPTA0</b>
	OUT20	O2		<b>OUT20 Line of GPTA1</b>
	OUT20	O3		<b>OUT20 Line of LTCA2</b>
<b>Port 4</b>				

## Pinning TC1791 Pin Configuration

**Table 2 Pin Definitions and Functions (cont'd)**

Pin	Symbol	Ctrl.	Type	Function
T12	P4.0	I/O	A1+/ PU	<b>Port 4 General Purpose I/O Line 0</b>
	IN24	I		<b>IN24 Line of GPTA0</b>
	IN24	I		<b>IN24 Line of GPTA1</b>
	IN24	I		<b>IN24 Line of LTCA2</b>
	MRST2A	I		<b>SSC2 Master Receive Input A (Master Mode)</b>
	OUT24	O1		<b>OUT24 Line of GPTA0</b>
	OUT24	O2		<b>OUT24 Line of GPTA1</b>
	MRST2	O3		<b>SSC2 Slave Transmit Output (Slave Mode)</b>
U12	P4.1	I/O	A1+/ PU	<b>Port 4 General Purpose I/O Line 1</b>
	IN25	I		<b>IN25 Line of GPTA0</b>
	IN25	I		<b>IN25 Line of GPTA1</b>
	IN25	I		<b>IN25 Line of LTCA2</b>
	MTRSR2A	I		<b>SSC2 Slave Receive Input A (Slave Mode)</b>
	MRSTG2A	I		<b>SSC Guardian 2 Master Receive Input A (Master Mode)<sup>3)</sup></b>
	OUT25	O1		<b>OUT25 Line of GPTA0</b>
	OUT25	O2		<b>OUT25 Line of GPTA1</b>
	MTRSR2	O3		<b>SSC2 Master Transmit Output (Master Mode)</b>

## Pinning TC1791 Pin Configuration

**Table 2 Pin Definitions and Functions (cont'd)**

Pin	Symbol	Ctrl.	Type	Function
W12	P4.2	I/O	A1+/ PU	<b>Port 4 General Purpose I/O Line 2</b>
	IN26	I		<b>IN26 Line of GPTA0</b>
	IN26	I		<b>IN26 Line of GPTA1</b>
	IN26	I		<b>IN26 Line of LTCA2</b>
	SCLK2	I		<b>SSC2 Input</b>
	OUT26	O1		<b>OUT26 Line of GPTA0</b>
	OUT26	O2		<b>OUT26 Line of GPTA1</b>
	SCLK2	O3		<b>SSC2 Output</b>
Y12	P4.3	I/O	A1+/ PU	<b>Port 4 General Purpose I/O Line 3</b>
	IN27	I		<b>IN27 Line of GPTA0</b>
	IN27	I		<b>IN27 Line of GPTA1</b>
	IN27	I		<b>IN27 Line of LTCA2</b>
	OUT27	O1		<b>OUT27 Line of GPTA0</b>
	OUT27	O2		<b>OUT27 Line of GPTA1</b>
	SLSO20	O3		<b>SSC2 Output</b>
T13	P4.4	I/O	A1+/ PU	<b>Port 4 General Purpose I/O Line 4</b>
	IN28	I		<b>IN28 Line of GPTA0</b>
	IN28	I		<b>IN28 Line of GPTA1</b>
	IN28	I		<b>IN28 Line of LTCA2</b>
	OUT28	O1		<b>OUT28 Line of GPTA0</b>
	OUT28	O2		<b>OUT28 Line of GPTA1</b>
	SLSO21	O3		<b>SSC2 Output</b>

## Pinning TC1791 Pin Configuration

**Table 2 Pin Definitions and Functions (cont'd)**

Pin	Symbol	Ctrl.	Type	Function
U13	P4.5	I/O	A1+/ PU	<b>Port 4 General Purpose I/O Line 5</b>
	IN29	I		<b>IN29 Line of GPTA0</b>
	IN29	I		<b>IN29 Line of GPTA1</b>
	IN29	I		<b>IN29 Line of LTCA2</b>
	OUT29	O1		<b>OUT29 Line of GPTA0</b>
	OUT29	O2		<b>OUT29 Line of GPTA1</b>
	SLSO22	O3		<b>SSC2 Output</b>
W13	P4.6	I/O	A1+/ PU	<b>Port 4 General Purpose I/O Line 6</b>
	IN30	I		<b>IN30 Line of GPTA0</b>
	IN30	I		<b>IN30 Line of GPTA1</b>
	IN30	I		<b>IN30 Line of LTCA2</b>
	OUT30	O1		<b>OUT30 Line of GPTA0</b>
	OUT30	O2		<b>OUT30 Line of GPTA1</b>
	SLSO23	O3		<b>SSC2 Output</b>
Y13	P4.7	I/O	A1+/ PU	<b>Port 4 General Purpose I/O Line 7</b>
	IN31	I		<b>IN31 Line of GPTA0</b>
	IN31	I		<b>IN31 Line of GPTA1</b>
	IN31	I		<b>IN31 Line of LTCA2</b>
	T6INB	I		<b>GPT120</b>
	T6INA	I		<b>GPT121</b>
	OUT31	O1		<b>OUT31 Line of GPTA0</b>
	OUT31	O2		<b>OUT31 Line of GPTA1</b>
	SLSO24	O3		<b>SSC2 Output</b>



## Pinning TC1791 Pin Configuration

**Table 2 Pin Definitions and Functions (cont'd)**

Pin	Symbol	Ctrl.	Type	Function
T14	P4.8	I/O	A1/ PU	<b>Port 4 General Purpose I/O Line 8</b>
	IN32	I		<b>IN32 Line of GPTA0</b>
	IN32	I		<b>IN32 Line of GPTA1</b>
	CCPOS1A	I		<b>CCU60</b>
	T13HRB	I		<b>CCU61</b>
	T3EUDA	I		<b>GPT120</b>
	T3EADB	I		<b>GPT121</b>
	OUT32	O1		<b>OUT32 Line of GPTA0</b>
	OUT32	O2		<b>OUT32 Line of GPTA1</b>
	OUT0	O3		<b>OUT0 Line of LTCA2</b>
AB19	P4.9	I/O	A1/ PU	<b>Port 4 General Purpose I/O Line 9</b>
	IN33	I		<b>IN33 Line of GPTA0</b>
	IN33	I		<b>IN33 Line of GPTA1</b>
	CCPOS2A	I		<b>CCU60</b>
	T12HRC	I		<b>CCU61</b>
	T13HRC	I		<b>CCU61</b>
	T4INA	I		<b>GPT120</b>
	T4INB	I		<b>GPT121</b>
	SLSI2	I		<b>SSC2</b>
	OUT33	O1		<b>OUT33 Line of GPTA0</b>
	OUT33	O2		<b>OUT33 Line of GPTA1</b>
	OUT1	O3		<b>OUT1 Line of LTCA2</b>

**Pinning TC1791 Pin Configuration**
**Table 2 Pin Definitions and Functions (cont'd)**

<b>Pin</b>	<b>Symbol</b>	<b>Ctrl.</b>	<b>Type</b>	<b>Function</b>
W14	P4.10	I/O	A1/ PU	<b>Port 4 General Purpose I/O Line 10</b>
	IN34	I		<b>IN34 Line of GPTA0</b>
	IN34	I		<b>IN34 Line of GPTA1</b>
	T12HRB	I		<b>CCU60</b>
	CCPOS0A	I		<b>CCU61</b>
	T2INA	I		<b>GPT120</b>
	T2INB	I		<b>GPT121</b>
	OUT34	O1		<b>OUT34 Line of GPTA0</b>
	OUT34	O2		<b>OUT34 Line of GPTA1</b>
	OUT2	O3		<b>OUT2 Line of LTCA2</b>
T15	P4.12	I/O	A1/ PU	<b>Port 4 General Purpose I/O Line 12</b>
	IN36	I		<b>IN36 Line of GPTA0</b>
	IN36	I		<b>IN36 Line of GPTA1</b>
	T13HRB	I		<b>CCU60</b>
	CCPOS1A	I		<b>CCU61</b>
	T2EUDA	I		<b>GPT120</b>
	T2EADB	I		<b>GPT121</b>
	OUT36	O1		<b>OUT36 Line of GPTA0</b>
	OUT36	O2		<b>OUT36 Line of GPTA1</b>
	OUT4	O3		<b>OUT4 Line of LTCA2</b>

## Pinning TC1791 Pin Configuration

**Table 2 Pin Definitions and Functions (cont'd)**

Pin	Symbol	Ctrl.	Type	Function
U15	P4.14	I/O	A1/ PU	<b>Port 4 General Purpose I/O Line 14</b>
	IN38	I		<b>IN38 Line of GPTA0</b>
	IN38	I		<b>IN38 Line of GPTA1</b>
	T12HRC	I		<b>CCU60</b>
	T13HRC	I		<b>CCU60</b>
	CCPOS2A	I		<b>CCU61</b>
	T4EUDA	I		<b>GPT120</b>
	T4EUDB	I		<b>GPT121</b>
	OUT38	O1		<b>OUT38 Line of GPTA0</b>
	OUT38	O2		<b>OUT38 Line of GPTA1</b>
OUT6	O3	<b>OUT6 Line of LTCA2</b>		
<b>Port 5</b>				
A15	P5.0	I/O	A1+/ PU	<b>Port 5 General Purpose I/O Line 0</b>
	RXD0A	I		<b>ASC0 Receiver Input/Output A</b>
	T6EUDA	I		<b>GPT120</b>
	T6EUDB	I		<b>GPT121</b>
	RXD0A	O1		<b>ASC0 Receiver Input/Output A</b>
	OUT72	O2		<b>OUT72 Line of GPTA0</b>
	OUT72	O3		<b>OUT72 Line of GPTA1</b>
A14	P5.1	I/O	A1+/ PU	<b>Port 5 General Purpose I/O Line 1</b>
	TXD0	O1		<b>ASC0 Transmitter Output A</b>
	OUT73	O2		<b>OUT73 Line of GPTA0</b>
	OUT73	O3		<b>OUT73 Line of GPTA1</b>

**Pinning TC1791 Pin Configuration**
**Table 2 Pin Definitions and Functions (cont'd)**

<b>Pin</b>	<b>Symbol</b>	<b>Ctrl.</b>	<b>Type</b>	<b>Function</b>
D15	P5.2	I/O	A2/ PU	<b>Port 5 General Purpose I/O Line 2</b>
	RXD1A	I		<b>ASC1 Receiver Input/Output A</b>
	RXD1A	O1		<b>ASC1 Receiver Input/Output A</b>
	OUT74	O2		<b>OUT74 Line of GPTA0</b>
	OUT74	O3		<b>OUT74 Line of GPTA1</b>
B15	P5.3	I/O	A1+/ PU	<b>Port 5 General Purpose I/O Line 3</b>
	TXD1	O1		<b>ASC1 Transmitter Output A</b>
	OUT75	O2		<b>OUT75 Line of GPTA0</b>
	OUT75	O3		<b>OUT75 Line of GPTA1</b>
A18	P5.4	I/O	A2/ PU	<b>Port 5 General Purpose I/O Line 4</b>
	T13HRB	I		<b>CCU62</b>
	CCPOS1A	I		<b>CCU63</b>
	T2EUDB	I		<b>GPT120</b>
	T2EUDA	I		<b>GPT121</b>
	EN00	O1		<b>MSC0 Device Select Output 0</b>
	RREADY0B	O2		<b>MLI0 Receive Channel ready Output B</b>
	OUT76	O3		<b>OUT76 Line of GPTA0</b>

**Pinning TC1791 Pin Configuration**
**Table 2 Pin Definitions and Functions (cont'd)**

<b>Pin</b>	<b>Symbol</b>	<b>Ctrl.</b>	<b>Type</b>	<b>Function</b>
<b>E15</b>	<b>P5.5</b>	<b>I/O</b>	<b>A1+/ PU</b>	<b>Port 5 General Purpose I/O Line 5</b>
	<b>SDI0</b>	<b>I</b>		<b>MSC0 Serial Data Input</b>
	<b>T12HRC</b>	<b>I</b>		<b>CCU62</b>
	<b>T13HRC</b>	<b>I</b>		<b>CCU62</b>
	<b>CCPOS2A</b>	<b>I</b>		<b>CCU63</b>
	<b>T4EUDB</b>	<b>I</b>		<b>GPT120</b>
	<b>T4EUDA</b>	<b>I</b>		<b>GPT121</b>
	<b>OUT77</b>	<b>O1</b>		<b>OUT77 Line of GPTA0</b>
	<b>OUT77</b>	<b>O2</b>		<b>OUT77 Line of GPTA1</b>
	<b>OUT101</b>	<b>O3</b>		<b>OUT101 Line of LTCA2</b>
<b>B20</b>	<b>P5.6</b>	<b>I/O</b>	<b>A2/ PU</b>	<b>Port 5 General Purpose I/O Line 6</b>
	<b>CC60INA</b>	<b>I</b>		<b>CCU62</b>
	<b>CC60INB</b>	<b>I</b>		<b>CCU63</b>
	<b>EN10</b>	<b>O1</b>		<b>MSC1 Device Select Output 0</b>
	<b>TVALID0B</b>	<b>O2</b>		<b>MLI0 transmit Channel valid Output B</b>
	<b>CC60</b>	<b>O3</b>		<b>CCU62</b>
<b>D16</b>	<b>P5.7</b>	<b>I/O</b>	<b>A1+/ PU</b>	<b>Port 5 General Purpose I/O Line 7</b>
	<b>SDI1</b>	<b>I</b>		<b>MSC1 Serial Data Input</b>
	<b>CC61INA</b>	<b>I</b>		<b>CCU62</b>
	<b>CC61INB</b>	<b>I</b>		<b>CCU63</b>
	<b>OUT79</b>	<b>O1</b>		<b>OUT79 Line of GPTA0</b>
	<b>OUT79</b>	<b>O2</b>		<b>OUT79 Line of GPTA1</b>
	<b>CC61</b>	<b>O3</b>		<b>CCU62</b>

## PinningTC1791 Pin Configuration

**Table 2 Pin Definitions and Functions (cont'd)**

Pin	Symbol	Ctrl.	Type	Function
B16	P5.8	I/O	F/ PU	<b>Port 5 General Purpose I/O Line 8</b>
	CC62INA	I		<b>CCU62</b>
	CC62INB	I		<b>CCU63</b>
	SON0	O1		<b>MSC0 Differential Driver Serial Data Output Negative</b>
	OUT80	O2		<b>OUT80 Line of GPTA0</b>
	CC62	O3		<b>CCU62</b>
B17	P5.9	I/O	F/ PU	<b>Port 5 General Purpose I/O Line 9</b>
	SOP0A	O1		<b>MSC0 Differential Driver Serial Data Output Positive A</b>
	OUT81	O2		<b>OUT81 Line of GPTA0</b>
	COU60	O3		<b>CCU62</b>
A16	P5.10	I/O	F/ PU	<b>Port 5 General Purpose I/O Line 10</b>
	FCLN0	O1		<b>MSC0 Differential Driver Clock Output Negative</b>
	OUT82	O2		<b>OUT82 Line of GPTA0</b>
	COU61	O3		<b>CCU62</b>
A17	P5.11	I/O	F/ PU	<b>Port 5 General Purpose I/O Line 11</b>
	FCLP0A	O1		<b>MSC0 Differential Driver Clock Output Positive A</b>
	OUT83	O2		<b>OUT83 Line of GPTA0</b>
	COU62	O3		<b>CCU62</b>
D14	P5.12	I/O	F/ PU	<b>Port 5 General Purpose I/O Line 12</b>
	SON1	O1		<b>MSC1 Differential Driver Serial Data Output Negative</b>
	OUT84	O2		<b>OUT84 Line of GPTA0</b>
	OUT84	O3		<b>OUT84 Line of GPTA1</b>

## PinningTC1791 Pin Configuration

**Table 2 Pin Definitions and Functions (cont'd)**

Pin	Symbol	Ctrl.	Type	Function
B14	P5.13	I/O	F/ PU	<b>Port 5 General Purpose I/O Line 13</b>
	SOP1A	O1		<b>MSC1 Differential Driver Serial Data Output Positive A</b>
	OUT85	O2		<b>OUT85 Line of GPTA0</b>
	OUT85	O3		<b>OUT85 Line of GPTA1</b>
B13	P5.14	I/O	F/ PU	<b>Port 5 General Purpose I/O Line 14</b>
	FCLN1	O1		<b>MSC1 Differential Driver Clock Output Negative</b>
	OUT86	O2		<b>OUT86 Line of GPTA0</b>
	OUT86	O3		<b>OUT86 Line of GPTA1</b>
A13	P5.15	I/O	F/ PU	<b>Port 5 General Purpose I/O Line 15</b>
	FCLNP1A	O1		<b>MSC1 Differential Driver Clock Output Positive A</b>
	OUT87	O2		<b>OUT87 Line of GPTA0</b>
	OUT87	O3		<b>OUT87 Line of GPTA1</b>
<b>Port 6</b>				
B4	P6.4	I/O	A1+/ PU	<b>Port 6 General Purpose I/O Line 4</b>
	MTSR1	I		<b>SSC1 Slave Receive Input (Slave Mode)</b>
	MRSTG1	I		<b>SSC Guardian 1 Master Receive Input (Master Mode)</b>
	MTSR1	O1		<b>SSC1 Master Transmit Output (Master Mode)<sup>3)</sup></b>
	Reserved	O2		-
	Reserved	O3		-

## Pinning TC1791 Pin Configuration

**Table 2 Pin Definitions and Functions (cont'd)**

Pin	Symbol	Ctrl.	Type	Function
A3	P6.5	I/O	A1+/ PU	<b>Port 6 General Purpose I/O Line 5</b>
	MRST1	I		<b>SSC1 Master Receive Input (Master Mode)</b>
	MRST1	O1		<b>SSC1 Slave Transmit Output (Slave Mode)</b>
	Reserved	O2		-
	Reserved	O3		-
A4	P6.6	I/O	A1+/ PU	<b>Port 6 General Purpose I/O Line 6</b>
	SCLK1	I		<b>SSC1 Clock Input/Output</b>
	SCLK1	O1		<b>SSC1 Clock Input/Output</b>
	Reserved	O2		-
	Reserved	O3		-
D5	P6.7	I/O	A1+/ PU	<b>Port 6 General Purpose I/O Line 7</b>
	SLS11	I		<b>SSC1 slave Select Input</b>
	T6OFL	O1		<b>GPT120</b>
	Reserved	O2		-
	Reserved	O3		-
B5	P6.8	I/O	A2/ PU	<b>Port 6 General Purpose I/O Line 8</b>
	RXDCAN0	I		<b>CAN Node 0 Receiver Input 0 CAN Node 3 Receiver Input 1</b>
	RXD0B	I		<b>ASC0 Receiver Input/Output B</b>
	CAPINB	I		<b>GPT120</b>
	CAPINA	I		<b>GPT121</b>
	Reserved	O1		-
	RXD0B	O2		<b>ASC0 Receiver Input/Output B</b>
	Reserved	O3		-



**Pinning TC1791 Pin Configuration**
**Table 2 Pin Definitions and Functions (cont'd)**

<b>Pin</b>	<b>Symbol</b>	<b>Ctrl.</b>	<b>Type</b>	<b>Function</b>
A5	P6.9	I/O	A2/ PU	<b>Port 6 General Purpose I/O Line 9</b>
	TXDCAN0	O1		<b>CAN Node 0 Transmitter Output</b>
	TXD0	O2		<b>ASC0 Transmitter Output B</b>
	T60FL	O3		<b>GPT120</b>
C2	P6.10	I/O	A2/ PU	<b>Port 6 General Purpose I/O Line 10</b>
	RXDCAN1	I		<b>CAN Node 1 Receiver Input 0 CAN Node 0 Receiver Input 1</b>
	RXD1B	I		<b>ASC1 Receiver Input/Output B</b>
	Reserved	O1		-
	RXD1B	O2		<b>ASC1 Receiver Input/Output B</b>
	TXENA	O3		<b>E-Ray Channel A transmit Data Output enable <sup>2)</sup></b>
D2	P6.11	I/O	A2/ PU	<b>Port 6 General Purpose I/O Line 11</b>
	TXDCAN1	O1		<b>CAN Node 1 Transmitter Output</b>
	TXD1	O2		<b>ASC1 Transmitter Output B</b>
	TXENB	O3		<b>E-Ray Channel B transmit Data Output enable <sup>2)</sup></b>
B1	P6.12	I/O	A1/ PU	<b>Port 6 General Purpose I/O Line 12</b>
	RXDCAN2	I		<b>CAN Node 2 Receiver Input 0 CAN Node 1 Receiver Input 1</b>
	RXDA1	I		<b>E-Ray Channel A Receive Data Input 1 <sup>2)</sup></b>
	Reserved	O1		-
	Reserved	O2		-
	COUT61	O3		<b>CCU60</b>

## PinningTC1791 Pin Configuration

**Table 2 Pin Definitions and Functions (cont'd)**

Pin	Symbol	Ctrl.	Type	Function
C1	P6.13	I/O	A2/ PU	<b>Port 6 General Purpose I/O Line 13</b>
	TXDCAN2	O1		<b>CAN Node 2 Transmitter Output</b>
	TXDA	O2		<b>E-Ray Channel A transmit Data Output <sup>2)</sup></b>
	COU62	O3		<b>CCU60</b>
D1	P6.14	I/O	A1/ PU	<b>Port 6 General Purpose I/O Line 14</b>
	RXDCAN3	I		<b>CAN Node 3 Receiver Input 0 CAN Node 2 Receiver Input 1</b>
	RXDB1	I		<b>E-Ray Channel B Receive Data Input 1 <sup>2)</sup></b>
	Reserved	O1		-
	Reserved	O2		-
	COU63	O3		<b>CCU60</b>
E1	P6.15	I/O	A2/ PU	<b>Port 6 General Purpose I/O Line 15</b>
	CC60INB	I		<b>CCU60</b>
	CC60INA	I		<b>CCU61</b>
	TXDCAN3	O1		<b>CAN Node 3 Transmitter Output</b>
	TXDB	O2		<b>E-Ray Channel B transmit Data Output <sup>2)</sup></b>
	CC60	O3		<b>CCU61</b>
<b>Port 7</b>				
H5	P7.0	I/O	A1+/ PU	<b>Port 7 General Purpose I/O Line 0</b>
	MRST3	I		<b>SSC3 Master Receive Input (Slave Mode)</b>
	REQ4	I		<b>External trigger Input 4</b>
	AD2EMUX2	O1		<b>ADC2 external multiplexer Control Output 2</b>
	MRST3	O2		<b>SSC3 Slave Transmit Output (Master Mode)</b>
	Reserved	O3		-

## Pinning TC1791 Pin Configuration

**Table 2 Pin Definitions and Functions (cont'd)**

Pin	Symbol	Ctrl.	Type	Function
J1	P7.1	I/O	A1+/ PU	<b>Port 7 General Purpose I/O Line 1</b>
	REQ5	I		<b>External trigger Input 5</b>
	MTSR3	I		<b>SSC3 Slave Receive Input (Slave Mode)</b>
	MRSTG3B	I		<b>SSC Guardian 3 Master Receive Input B (Master Mode)</b>
	AD0EMUX2	O1		<b>ADC0 external multiplexer Control Output 2</b>
	MTSR3	O2		<b>SSC3 Master Transmit Output (Master Mode)<sup>3)</sup></b>
	Reserved	O3		-
J2	P7.2	I/O	A1+/ PU	<b>Port 7 General Purpose I/O Line 2</b>
	SCLK3	I		<b>SSC3 Input</b>
	AD0EMUX0	O1		<b>ADC0 external multiplexer Control Output 0</b>
	SCLK3	O2		<b>SSC3 Output</b>
	Reserved	O3		-
J4	P7.3	I/O	A1+/ PU	<b>Port 7 General Purpose I/O Line 3</b>
	AD0EMUX1	O1		<b>ADC0 external multiplexer Control Output 1</b>
	SLSO30	O2		<b>SSC3 Output</b>
	Reserved	O3		-
J5	P7.4	I/O	A1+/ PU	<b>Port 7 General Purpose I/O Line 4</b>
	REQ6	I		<b>External trigger Input 6</b>
	AD2EMUX0	O1		<b>ADC2 external multiplexer Control Output 0</b>
	SLSO31	O2		<b>SSC3 Output</b>
	Reserved	O3		-

**Pinning TC1791 Pin Configuration**
**Table 2 Pin Definitions and Functions (cont'd)**

<b>Pin</b>	<b>Symbol</b>	<b>Ctrl.</b>	<b>Type</b>	<b>Function</b>
K4	P7.5	I/O	A1+/ PU	<b>Port 7 General Purpose I/O Line 5</b>
	REQ7	I		<b>External trigger Input 7</b>
	AD2EMUX1	O1		<b>ADC2 external multiplexer Control Output 1</b>
	SLSO32	O2		<b>SSC3 Output</b>
	Reserved	O3		-
<b>Port 8</b>				
F1	P8.0	I/O	A2/ PU	<b>Port 8 General Purpose I/O Line 0</b>
	IN40	I		<b>IN40 Line of GPTA0</b>
	IN40	I		<b>IN40 Line of GPTA1</b>
	SENT0	I		<b>SENT Digital Input</b>
	OUT40	O1		<b>OUT40 Line of GPTA0</b>
	COU62	O2		<b>CCU61</b>
	TCLK1	O3		<b>MLI1 transmit Channel Clock Output</b>
E6	P8.1	I/O	A1/ PU	<b>Port 8 General Purpose I/O Line 1</b>
	IN41	I		<b>IN41 Line of GPTA0</b>
	IN41	I		<b>IN41 Line of GPTA1</b>
	TREADY1A	I		<b>MLI1 transmit Channel ready Input A</b>
	SENT1	I		<b>SENT Digital Input</b>
	CC61INA	I		<b>CCU60</b>
	CC61INB	I		<b>CCU61</b>
	OUT41	O1		<b>OUT41 Line of GPTA0</b>
	CC61	O2		<b>CCU60</b>
	SENT1	O3		<b>SENT Digital Output</b>

## Pinning TC1791 Pin Configuration

**Table 2 Pin Definitions and Functions (cont'd)**

Pin	Symbol	Ctrl.	Type	Function
E4	P8.2	I/O	A2/ PU	<b>Port 8 General Purpose I/O Line 2</b>
	IN42	I		<b>IN42 Line of GPTA0</b>
	IN42	I		<b>IN42 Line of GPTA1</b>
	SENT2	I		<b>SENT Digital Input</b>
	CAPINA	I		<b>GPT120</b>
	CAPINB	I		<b>GPT121</b>
	COU63	O1		<b>CCU61</b>
	OUT42	O2		<b>OUT42 Line of GPTA1</b>
	TVALID1A	O3		<b>MLI1 transmit Channel valid Output A</b>
E2	P8.3	I/O	A2/ PU	<b>Port 8 General Purpose I/O Line 3</b>
	IN43	I		<b>IN43 Line of GPTA0</b>
	IN43	I		<b>IN43 Line of GPTA1</b>
	SENT3	I		<b>SENT Digital Input</b>
	CC62INA	I		<b>CCU60</b>
	CC62INB	I		<b>CCU61</b>
	OUT43	O1		<b>OUT43 Line of GPTA0</b>
	CC62	O2		<b>CCU60</b>
	TDATA1	O3		<b>MLI1 transmit Channel Data Output A</b>

Pinning TC1791 Pin Configuration

**Table 2 Pin Definitions and Functions (cont'd)**

Pin	Symbol	Ctrl.	Type	Function
F2	P8.4	I/O	A1/ PU	<b>Port 8 General Purpose I/O Line 4</b>
	IN44	I		<b>IN44 Line of GPTA0</b>
	IN44	I		<b>IN44 Line of GPTA1</b>
	RCLK1A	I		<b>MLI1 Receive Channel Clock Input A</b>
	SENT4	I		<b>SENT Digital Input</b>
	CC62INB	I		<b>CCU60</b>
	CC62INA	I		<b>CCU61</b>
	OUT44	O1		<b>OUT44 Line of GPTA0</b>
	CC62	O2		<b>CCU61</b>
	T3OUT	O3		<b>GPT121</b>
F5	P8.5	I/O	A2/ PU	<b>Port 8 General Purpose I/O Line 5</b>
	IN45	I		<b>IN45 Line of GPTA0</b>
	IN45	I		<b>IN45 Line of GPTA1</b>
	SENT5	I		<b>SENT Digital Input</b>
	CTRAPA	I		<b>CCU60</b>
	CTRAPB	I		<b>CCU62</b>
	CC60INC	I		<b>CCU60</b>
	T12HRE	I		<b>CCU61</b>
	CC61INC	I		<b>CCU61</b>
	OUT45	O1		<b>OUT45 Line of GPTA0</b>
	OUT45	O2		<b>OUT45 Line of GPTA1</b>
	RREADY1A	O3		<b>MLI1 Receive Channel ready Output A</b>

**Pinning TC1791 Pin Configuration**
**Table 2 Pin Definitions and Functions (cont'd)**

<b>Pin</b>	<b>Symbol</b>	<b>Ctrl.</b>	<b>Type</b>	<b>Function</b>
G4	P8.6	I/O	A1/ PU	<b>Port 8 General Purpose I/O Line 6</b>
	IN46	I		<b>IN46 Line of GPTA0</b>
	IN46	I		<b>IN46 Line of GPTA1</b>
	RVALID1A	I		<b>MLI1 Receive Channel valid Input A</b>
	SENT6	I		<b>SENT Digital Input</b>
	OUT46	O1		<b>OUT46 Line of GPTA0</b>
	COU60	O2		<b>CCU61</b>
	T6OUT	O3		<b>GPT120</b>
F4	P8.7	I/O	A1/ PU	<b>Port 8 General Purpose I/O Line 7</b>
	IN47	I		<b>IN47 Line of GPTA0</b>
	IN47	I		<b>IN47 Line of GPTA1</b>
	RDATA1A	I		<b>MLI1 Receive Channel Data Input A</b>
	SENT7	I		<b>SENT Digital Input</b>
	OUT47	O1		<b>OUT47 Line of GPTA0</b>
	COU61	O2		<b>CCU61</b>
	T6OUT	O3		<b>GPT121</b>
<b>Port 9</b>				
E17	P9.0	I/O	A2/ PU	<b>Port 9 General Purpose I/O Line 0</b>
	IN48	I		<b>IN48 Line of GPTA0</b>
	IN48	I		<b>IN48 Line of GPTA1</b>
	COU63	O1		<b>CCU62</b>
	OUT48	O2		<b>OUT48 Line of GPTA1</b>
	EN12	O3		<b>MSC1 Device Select Output 2</b>

## Pinning TC1791 Pin Configuration

**Table 2 Pin Definitions and Functions (cont'd)**

Pin	Symbol	Ctrl.	Type	Function
D19	P9.1	I/O	A2/ PU	<b>Port 9 General Purpose I/O Line 1</b>
	IN49	I		<b>IN49 Line of GPTA0</b>
	IN49	I		<b>IN49 Line of GPTA1</b>
	CC60INB	I		<b>CCU62</b>
	CC60INA	I		<b>CCU63</b>
	CC60	O1		<b>CCU63</b>
	OUT49	O2		<b>OUT49 Line of GPTA1</b>
	EN11	O3		<b>MSC1 Device Select Output 1</b>
D20	P9.2	I/O	A2/ PU	<b>Port 9 General Purpose I/O Line 2</b>
	IN50	I		<b>IN50 Line of GPTA0</b>
	IN50	I		<b>IN50 Line of GPTA1</b>
	CC61INB	I		<b>CCU62</b>
	CC61INA	I		<b>CCU63</b>
	CC61	O1		<b>CCU63</b>
	OUT50	O2		<b>OUT50 Line of GPTA1</b>
	SOP1B	O3		<b>MSC1 serial Data Output</b>
C20	P9.3	I/O	A2/ PU	<b>Port 9 General Purpose I/O Line 3</b>
	IN51	I		<b>IN51 Line of GPTA0</b>
	IN51	I		<b>IN51 Line of GPTA1</b>
	CC62INB	I		<b>CCU62</b>
	CC62INA	I		<b>CCU63</b>
	CC62	O1		<b>CCU63</b>
	OUT51	O2		<b>OUT51 Line of GPTA1</b>
	FCLP1B	O3		<b>MSC1 Clock Output</b>



## Pinning TC1791 Pin Configuration

**Table 2 Pin Definitions and Functions (cont'd)**

Pin	Symbol	Ctrl.	Type	Function
C19	P9.4	I/O	A2/ PU	<b>Port 9 General Purpose I/O Line 4</b>
	IN52	I		<b>IN52 Line of GPTA0</b>
	IN52	I		<b>IN52 Line of GPTA1</b>
	COU60	O1		<b>CCU63</b>
	OUT52	O2		<b>OUT52 Line of GPTA1</b>
	EN03	O3		<b>MSC0 Device Select Output 3</b>
F17	P9.5	I/O	A2/ PU	<b>Port 9 General Purpose I/O Line 5</b>
	IN53	I		<b>IN53 Line of GPTA0</b>
	IN53	I		<b>IN53 Line of GPTA1</b>
	SENT1	I		<b>SENT Digital Input</b>
	COU61	O1		<b>CCU63</b>
	OUT53	O2		<b>OUT53 Line of GPTA1</b>
	EN02	O3		<b>MSC0 Device Select Output 2</b>
F16	P9.6	I/O	A2/ PU	<b>Port 9 General Purpose I/O Line 6</b>
	IN54	I		<b>IN54 Line of GPTA0</b>
	IN54	I		<b>IN54 Line of GPTA1</b>
	SENT3	I		<b>SENT Digital Input</b>
	OUT54	O1		<b>OUT54 Line of GPTA0</b>
	SENT3	O2		<b>SENT Digital Output</b>
	EN01	O3		<b>MSC0 Device Select Output 1</b>

## Pinning TC1791 Pin Configuration

**Table 2 Pin Definitions and Functions (cont'd)**

Pin	Symbol	Ctrl.	Type	Function
E20	P9.7	I/O	A2/ PU	<b>Port 9 General Purpose I/O Line 7</b>
	IN55	I		<b>IN55 Line of GPTA0</b>
	IN55	I		<b>IN55 Line of GPTA1</b>
	SENT4	I		<b>SENT Digital Input</b>
	OUT55	O1		<b>OUT55 Line of GPTA0</b>
	SENT4	O2		<b>SENT Digital Output</b>
	SOP0B	O3		<b>MSC0 serial Data Output</b>
E19	P9.8	I/O	A2/ PU	<b>Port 9 General Purpose I/O Line 8</b>
	SENT6	I		<b>SENT Digital Input</b>
	COU62	O1		<b>CCU63</b>
	SENT6	O2		<b>SENT Digital Output</b>
	FCLP0B	O3		<b>MSC0 Clock Output</b>
F20	P9.10	I/O	A1/ PU	<b>Port 9 General Purpose I/O Line 10</b>
	EMGSTOP	I		<b>Emergency Stop</b>
	SENT7	I		<b>SENT Digital Input</b>
	COU63	O1		<b>CCU63</b>
	SENT7	O2		<b>SENT Digital Output</b>
	Reserved	O3		-
G16	P9.13	I/O	A2/ PU	<b>Port 9 General Purpose I/O Line 13</b>
	BRKIN	I		<b>OCDS Break Input</b>
	ECTT1	I		<b>TTCAN Input</b>
	Reserved	O1		-
	Reserved	O2		-
	Reserved	O3		-
	BRKOUT	O		<b>OCDS Break Output</b>

## Pinning TC1791 Pin Configuration

**Table 2 Pin Definitions and Functions (cont'd)**

Pin	Symbol	Ctrl.	Type	Function
H16	P9.14	I/O	A2/ PU	<b>Port 9 General Purpose I/O Line 14</b>
	$\overline{\text{BRKIN}}$	I		<b>OCDS Break Input</b>
	ECTT2	I		<b>TTCAN Input</b>
	REQ15	I		<b>External trigger Input 15</b>
	Reserved	O1		-
	Reserved	O2		-
	Reserved	O3		-
	$\overline{\text{BRKOUT}}$	O		<b>OCDS Break Output</b>
<b>Port 10</b>				
Y15	P10.0	I/O	A2/ PU	<b>Port 10 General Purpose I/O Line 0</b>
	MRST0	I		<b>SSC0 Master Receive Input (Master Mode)</b>
	MRST0	O1		<b>SSC0 Slave Transmit Output (Slave Mode)</b>
	Reserved	O2		-
	Reserved	O3		-
W15	P10.1	I/O	A2/ PU	<b>Port 10 General Purpose I/O Line 1</b>
	MTSR0	I		<b>SSC0 Slave Receive Input (Slave Mode)</b>
	MRSTG0	I		<b>SSC Guardian 0 Master Receive Input (Master Mode)</b>
	MTSR0	O1		<b>SSC0 Master Transmit Output (Master Mode)</b>
	Reserved	O2		-
	Reserved	O3		-

## PinningTC1791 Pin Configuration

**Table 2 Pin Definitions and Functions (cont'd)**

Pin	Symbol	Ctrl.	Type	Function
U16	P10.2	I/O	A1/ PU	<b>Port 10 General Purpose I/O Line 2</b>
	SLSI0	I		<b>SSC0 Slave Select Input</b>
	Reserved	O1		-
	Reserved	O2		-
	Reserved	O3		-
Y14	P10.3	I/O	A2/ PU	<b>Port 10 General Purpose I/O Line 3</b>
	SCLK0	I		<b>SSC0 Clock Input/Output</b>
	SCLK0	O1		<b>SSC0 Clock Input/Output</b>
	Reserved	O2		-
	Reserved	O3		-
W16	P10.4	I/O	A1+/ PU	<b>Port 10 General Purpose I/O Line 4</b>
	SLSO0	O1		<b>SSC0 Slave Select Output Line 0</b>
	Reserved	O2		-
	Reserved	O3		-
Y16	P10.5	I/O	A1+/ PU	<b>Port 10 General Purpose I/O Line 5</b>
	SLSO1	O1		<b>SSC0 Slave Select Output Line 1</b>
	Reserved	O2		-
	Reserved	O3		-
<b>Port 13</b>				
M16	P13.0	I/O	A2/ PU	<b>Port 13 General Purpose I/O Line 0</b>
	OUT88	O1		<b>OUT88 Line of GPTA0</b>
	OUT88	O2		<b>OUT88 Line of GPTA1</b>
	OUT80	O3		<b>OUT80 Line of LTCA2</b>

**Pinning TC1791 Pin Configuration**
**Table 2 Pin Definitions and Functions (cont'd)**

<b>Pin</b>	<b>Symbol</b>	<b>Ctrl.</b>	<b>Type</b>	<b>Function</b>
M17	P13.1	I/O	A2/ PU	<b>Port 13 General Purpose I/O Line 1</b>
	OUT89	O1		<b>OUT89 Line of GPTA0</b>
	OUT89	O2		<b>OUT89 Line of GPTA1</b>
	OUT81	O3		<b>OUT81 Line of LTCA2</b>
N16	P13.2	I/O	A2/ PU	<b>Port 13 General Purpose I/O Line 2</b>
	OUT90	O1		<b>OUT90 Line of GPTA0</b>
	OUT90	O2		<b>OUT90 Line of GPTA1</b>
	OUT82	O3		<b>OUT82 Line of LTCA2</b>
N17	P13.3	I/O	A2/ PU	<b>Port 13 General Purpose I/O Line 3</b>
	OUT91	O1		<b>OUT91 Line of GPTA0</b>
	OUT91	O2		<b>OUT91 Line of GPTA1</b>
	OUT83	O3		<b>OUT83 Line of LTCA2</b>
N19	P13.4	I/O	A2/ PU	<b>Port 13 General Purpose I/O Line 4</b>
	OUT92	O1		<b>OUT92 Line of GPTA0</b>
	OUT92	O2		<b>OUT92 Line of GPTA1</b>
	OUT84	O3		<b>OUT84 Line of LTCA2</b>
N20	P13.5	I/O	A2/ PU	<b>Port 13 General Purpose I/O Line 5</b>
	OUT93	O1		<b>OUT93 Line of GPTA0</b>
	OUT93	O2		<b>OUT93 Line of GPTA1</b>
	OUT85	O3		<b>OUT85 Line of LTCA2</b>
P16	P13.6	I/O	A2/ PU	<b>Port 13 General Purpose I/O Line 6</b>
	OUT94	O1		<b>OUT94 Line of GPTA0</b>
	OUT94	O2		<b>OUT94 Line of GPTA1</b>
	OUT86	O3		<b>OUT86 Line of LTCA2</b>

**Pinning TC1791 Pin Configuration**
**Table 2 Pin Definitions and Functions (cont'd)**

<b>Pin</b>	<b>Symbol</b>	<b>Ctrl.</b>	<b>Type</b>	<b>Function</b>
P17	P13.7	I/O	A2/ PU	<b>Port 13 General Purpose I/O Line 7</b>
	OUT95	O1		<b>OUT95 Line of GPTA0</b>
	OUT95	O2		<b>OUT95 Line of GPTA1</b>
	OUT87	O3		<b>OUT87 Line of LTCA2</b>
P19	P13.8	I/O	A2/ PU	<b>Port 13 General Purpose I/O Line 8</b>
	OUT96	O1		<b>OUT96 Line of GPTA0</b>
	OUT96	O2		<b>OUT96 Line of GPTA1</b>
	OUT88	O3		<b>OUT88 Line of LTCA2</b>
P20	P13.9	I/O	A2/ PU	<b>Port 13 General Purpose I/O Line 9</b>
	OUT97	O1		<b>OUT97 Line of GPTA0</b>
	OUT97	O2		<b>OUT97 Line of GPTA1</b>
	OUT89	O3		<b>OUT89 Line of LTCA2</b>
R17	P13.10	I/O	A2/ PU	<b>Port 13 General Purpose I/O Line 10</b>
	OUT98	O1		<b>OUT98 Line of GPTA0</b>
	OUT98	O2		<b>OUT98 Line of GPTA1</b>
	OUT90	O3		<b>OUT90 Line of LTCA2</b>
R19	P13.11	I/O	A2/ PU	<b>Port 13 General Purpose I/O Line 11</b>
	OUT99	O1		<b>OUT99 Line of GPTA0</b>
	OUT99	O2		<b>OUT99 Line of GPTA1</b>
	OUT91	O3		<b>OUT91 Line of LTCA2</b>
R20	P13.12	I/O	A2/ PU	<b>Port 13 General Purpose I/O Line 12</b>
	OUT100	O1		<b>OUT100 Line of GPTA0</b>
	OUT100	O2		<b>OUT100 Line of GPTA1</b>
	OUT92	O3		<b>OUT92 Line of LTCA2</b>

## PinningTC1791 Pin Configuration

**Table 2 Pin Definitions and Functions (cont'd)**

Pin	Symbol	Ctrl.	Type	Function
T19	P13.13	I/O	A2/ PU	<b>Port 13 General Purpose I/O Line 13</b>
	OUT101	O1		<b>OUT101 Line of GPTA0</b>
	OUT101	O2		<b>OUT101 Line of GPTA1</b>
	OUT93	O3		<b>OUT93 Line of LTCA2</b>
T20	P13.14	I/O	A2/ PU	<b>Port 13 General Purpose I/O Line 14</b>
	OUT102	O1		<b>OUT102 Line of GPTA0</b>
	OUT102	O2		<b>OUT102 Line of GPTA1</b>
	OUT94	O3		<b>OUT94 Line of LTCA2</b>
U19	P13.15	I/O	A2/ PU	<b>Port 13 General Purpose I/O Line 15</b>
	OUT103	O1		<b>OUT103 Line of GPTA0</b>
	OUT103	O2		<b>OUT103 Line of GPTA1</b>
	OUT95	O3		<b>OUT95 Line of LTCA2</b>
<b>Port 14</b>				
U20	P14.0	I/O	A2/ PU	<b>Port 14 General Purpose I/O Line 0</b>
	CC60	O1		<b>CCU60</b>
	OUT96	O2		<b>OUT96 Line of GPTA1</b>
	OUT96	O3		<b>OUT96 Line of LTCA2</b>
V20	P14.2	I/O	A2/ PU	<b>Port 14 General Purpose I/O Line 2</b>
	CC62	O1		<b>CCU60</b>
	OUT98	O2		<b>OUT98 Line of GPTA1</b>
	OUT98	O3		<b>OUT98 Line of LTCA2</b>
W18	P14.4	I/O	A2/ PU	<b>Port 14 General Purpose I/O Line 4</b>
	COU61	O1		<b>CCU60</b>
	OUT100	O2		<b>OUT100 Line of GPTA1</b>
	OUT100	O3		<b>OUT100 Line of LTCA2</b>

## Pinning TC1791 Pin Configuration

**Table 2 Pin Definitions and Functions (cont'd)**

Pin	Symbol	Ctrl.	Type	Function
Y19	P14.6	I/O	A2/ PU	<b>Port 14 General Purpose I/O Line 6</b>
	COU63	O1		<b>CCU60</b>
	OUT102	O2		<b>OUT102 Line of GPTA1</b>
	OUT102	O3		<b>OUT102 Line of LTCA2</b>
Y18	P14.8	I/O	A2/ PU	<b>Port 14 General Purpose I/O Line 8</b>
	CC61	O1		<b>CCU61</b>
	T3OUT	O2		<b>GPT120</b>
	OUT104	O3		<b>OUT104 Line of LTCA2</b>
<b>Port 17</b>				
R5	P17.0	I	D / S	<b>Port 17 General Purpose I Line 0<sup>4)</sup></b>
	SENT0	I		<b>SENT Digital Input 0</b>
	AN8	I		<b>Analog Input : ADC0.CH8<sup>5)</sup></b>
R4	P17.1	I	D / S	<b>Port 17 General Purpose I Line 1<sup>4)</sup></b>
	SENT1	I		<b>SENT Digital Input 1</b>
	AN9	I		<b>Analog Input : ADC0.CH9<sup>5)</sup></b>
P5	P17.2	I	D / S	<b>Port 17 General Purpose I Line 2<sup>4)</sup></b>
	SENT2	I		<b>SENT Digital Input 2</b>
	AN10	I		<b>Analog Input : ADC0.CH10<sup>5)</sup></b>
P4	P17.3	I	D / S	<b>Port 17 General Purpose I Line 3<sup>4)</sup></b>
	SENT3	I		<b>SENT Digital Input 3</b>
	AN11	I		<b>Analog Input : ADC0.CH11<sup>5)</sup></b>
P2	P17.4	I	D / S	<b>Port 17 General Purpose I Line 4<sup>4)</sup></b>
	SENT4	I		<b>SENT Digital Input 4</b>
	AN12	I		<b>Analog Input : ADC0.CH12<sup>5)</sup></b>



**Pinning TC1791 Pin Configuration**
**Table 2 Pin Definitions and Functions (cont'd)**

Pin	Symbol	Ctrl.	Type	Function
P1	P17.5	I	D / S	Port 17 General Purpose I Line 5 <sup>4)</sup>
	SENT5	I		SENT Digital Input 5
	AN13	I		Analog Input : ADC0.CH13 <sup>5)</sup>
N2	P17.6	I	D / S	Port 17 General Purpose I Line 6 <sup>4)</sup>
	SENT6	I		SENT Digital Input 6
	AN14	I		Analog Input : ADC0.CH14 <sup>5)</sup>
N1	P17.7	I	D / S	Port 17 General Purpose I Line 7 <sup>4)</sup>
	SENT7	I		SENT Digital Input 7
	AN15	I		Analog Input : ADC0.CH15 <sup>5)</sup>
W4	P17.8	I	D / S	Port 17 General Purpose I Line 8 <sup>4)</sup>
	SENT0	I		SENT Digital Input 0
	AN36	I		Analog Input : ADC2.CH4 <sup>5)</sup>
Y4	P17.9	I	D / S	Port 17 General Purpose I Line 9 <sup>4)</sup>
	SENT1	I		SENT Digital Input 1
	AN37	I		Analog Input : ADC2.CH5 <sup>5)</sup>
W5	P17.10	I	D / S	Port 17 General Purpose I Line 10 <sup>4)</sup>
	SENT2	I		SENT Digital Input 2
	AN38	I		Analog Input : ADC2.CH6 <sup>5)</sup>
Y5	P17.11	I	D / S	Port 17 General Purpose I Line 11 <sup>4)</sup>
	SENT3	I		SENT Digital Input 3
	AN39	I		Analog Input : ADC2.CH7 <sup>5)</sup>
T6	P17.12	I	D / S	Port 17 General Purpose I Line 12 <sup>4)</sup>
	SENT4	I		SENT Digital Input 4
	AN40	I		Analog Input : ADC2.CH8 <sup>5)</sup>

## PinningTC1791 Pin Configuration

**Table 2 Pin Definitions and Functions (cont'd)**

Pin	Symbol	Ctrl.	Type	Function
U6	P17.13	I	D / S	Port 17 General Purpose I Line 13 <sup>4)</sup>
	SENT5	I		SENT Digital Input 5
	AN41	I		Analog Input : ADC2.CH9 <sup>5)</sup>
T7	P17.14	I	D / S	Port 17 General Purpose I Line 14 <sup>4)</sup>
	SENT6	I		SENT Digital Input 6
	AN42	I		Analog Input : ADC2.CH10 <sup>5)</sup>
U7	P17.15	I	D / S	Port 17 General Purpose I Line 15 <sup>4)</sup>
	SENT7	I		SENT Digital Input 7
	AN43	I		Analog Input : ADC2.CH11 <sup>5)</sup>
<b>Analog Input Port</b>				
T4	AN0	I	D	Analog Input 0: ADC0.CH0 <sup>5)</sup>
Y2	AN1	I	D	Analog Input 1: ADC0.CH1 <sup>5)</sup>
W2	AN2	I	D	Analog Input 2: ADC0.CH2 <sup>5)</sup>
W1	AN3	I	D	Analog Input 3: ADC0.CH3 <sup>5)</sup>
V2	AN4	I	D	Analog Input 4: ADC0.CH4 <sup>5)</sup>
U2	AN5	I	D	Analog Input 5: ADC0.CH5 <sup>5)</sup>
T2	AN6	I	D	Analog Input 6: ADC0.CH6 <sup>5)</sup>
T5	AN7	I	D	Analog Input 7: ADC0.CH7 <sup>5)</sup>
R5	AN8	I	D / S	Analog Input 8: ADC0.CH8, SENT0 <sup>5)</sup>
R4	AN9	I	D / S	Analog Input 9: ADC0.CH9, SENT1 <sup>5)</sup>
P5	AN10	I	D / S	Analog Input 10: ADC0.CH10, SENT2 <sup>5)</sup>
P4	AN11	I	D / S	Analog Input 11: ADC0.CH11, SENT3 <sup>5)</sup>
P2	AN12	I	D / S	Analog Input 12: ADC0.CH12, SENT4 <sup>5)</sup>
P1	AN13	I	D / S	Analog Input 13: ADC0.CH13, SENT5 <sup>5)</sup>
N2	AN14	I	D / S	Analog Input 14: ADC0.CH14, SENT6 <sup>5)</sup>
N1	AN15	I	D / S	Analog Input 15: ADC0.CH15, SENT7 <sup>5)</sup>

**Pinning TC1791 Pin Configuration**
**Table 2 Pin Definitions and Functions (cont'd)**

<b>Pin</b>	<b>Symbol</b>	<b>Ctrl.</b>	<b>Type</b>	<b>Function</b>
N5	AN16	I	D	<b>Analog Input 16: ADC1.CH0</b> <sup>5)</sup>
N4	AN17	I	D	<b>Analog Input 17: ADC1.CH1</b> <sup>5)</sup>
M5	AN18	I	D	<b>Analog Input 18: ADC1.CH2</b> <sup>5)</sup>
M4	AN19	I	D	<b>Analog Input 19: ADC1.CH3</b> <sup>5)</sup>
M2	AN20	I	D	<b>Analog Input 20: ADC1.CH4</b> <sup>5)</sup>
M1	AN21	I	D	<b>Analog Input 21: ADC1.CH5</b> <sup>5)</sup>
L2	AN22	I	D	<b>Analog Input 22: ADC1.CH6</b> <sup>5)</sup>
L1	AN23	I	D	<b>Analog Input 23: ADC1.CH7</b> <sup>5)</sup>
U8	AN24	I	D	<b>Analog Input 24: ADC1.CH8, FADC_FADIN0P</b> <sup>6)</sup>
W8	AN25	I	D	<b>Analog Input 25: ADC1.CH9, FADC_FADIN0N</b> <sup>6)</sup>
Y8	AN26	I	D	<b>Analog Input 26: ADC1.CH10, FADC_FADIN1P</b> <sup>6)</sup>
T9	AN27	I	D	<b>Analog Input 27: ADC1.CH11, FADC_FADIN1N</b> <sup>6)</sup>
U9	AN28	I	D	<b>Analog Input 28: ADC1.CH12, FADC_FADIN2P</b> <sup>6)</sup>
W9	AN29	I	D	<b>Analog Input 29: ADC1.CH13, FADC_FADIN2N</b> <sup>6)</sup>
Y9	AN30	I	D	<b>Analog Input 30: ADC1.CH14, FADC_FADIN3P</b> <sup>6)</sup>
T10	AN31	I	D	<b>Analog Input 31: ADC1.CH15, FADC_FADIN3N</b> <sup>6)</sup>
U4	AN32	I	D	<b>Analog Input 32: ADC2.CH0</b> <sup>5)</sup>
W3	AN33	I	D	<b>Analog Input 33: ADC2.CH1</b> <sup>5)</sup>
Y3	AN34	I	D	<b>Analog Input 34: ADC2.CH2</b> <sup>5)</sup>
T8	AN35	I	D	<b>Analog Input 35: ADC2.CH3</b> <sup>5)</sup>

## PinningTC1791 Pin Configuration

**Table 2 Pin Definitions and Functions (cont'd)**

Pin	Symbol	Ctrl.	Type	Function
W4	AN36	I	D	Analog Input 36: ADC2.CH4, SENT0 <sup>5)</sup>
Y4	AN37	I	D	Analog Input 37: ADC2.CH5, SENT1 <sup>5)</sup>
W5	AN38	I	D	Analog Input 38: ADC2.CH6, SENT2 <sup>5)</sup>
Y5	AN39	I	D	Analog Input 39: ADC2.CH7, SENT3 <sup>5)</sup>
T6	AN40	I	D	Analog Input 40: ADC2.CH8, SENT4 <sup>5)</sup>
U6	AN41	I	D	Analog Input 41: ADC2.CH9, SENT5 <sup>5)</sup>
T7	AN42	I	D	Analog Input 42: ADC2.CH10, SENT6 <sup>5)</sup>
U7	AN43	I	D	Analog Input 43: ADC2.CH11, SENT7 <sup>5)</sup>
V1	AN44	I	D	Analog Input 44: ADC2.CH12 <sup>5)</sup>
U1	AN45	I	D	Analog Input 45: ADC2.CH13 <sup>5)</sup>
T1	AN46	I	D	Analog Input 46: ADC2.CH14 <sup>5)</sup>
U5	AN47	I	D	Analog Input 47: ADC2.CH15 <sup>5)</sup>
<b>System I/O</b>				
F19	$\overline{\text{PORST}}$	I	PD	<b>Power-on Reset Input</b>
G19	$\overline{\text{ESR0}}$	I/O	A2	<b>External System Request Reset Input 0</b> Default configuration during and after reset is open-drain driver. The driver drives low during power-on reset.
G20	$\overline{\text{ESR1}}$	I/O	A2/ PD	<b>External System Request Reset Input 1</b>
H20	TCK	I	PD	<b>JTAG Module Clock Input</b>
	DAPO	I		<b>Device Access Port Line 0</b>
J17	TDI	I	A2/ PU	<b>JTAG Module Serial Data Input</b>
	$\overline{\text{BRKIN}}$	I		<b>OCDS Break Input (Alternate Output)</b>
	$\overline{\text{BRKOUT}}$	O		<b>OCDS Break Output (Alternate Input)</b>
G17	$\overline{\text{TESTMODE}}$	I	PU	<b>Test Mode Select Input</b>

## Pinning TC1791 Pin Configuration

**Table 2 Pin Definitions and Functions (cont'd)**

Pin	Symbol	Ctrl.	Type	Function
J16	TMS	I	A2/ PD	<b>JTAG Module State Machine Control Input</b>
	DAP1	I/O		<b>Device Access Port Line 1</b>
H19	TRST	I	PD	<b>JTAG Module Reset/Enable Input</b>
K20	XTAL1	I		<b>Main Oscillator/PLL/Clock Generator Input</b>
K19	XTAL2	O		<b>Main Oscillator/PLL/Clock Generator Output</b>
H17	TDO	O	A2/ PU	<b>JTAG Module Serial Data Output</b>
	BRKIN	I		<b>OCDS Break Input (Alternate Input)</b>
	BRKOUT	O		<b>OCDS Break Output (Alternate Output)</b>
	DAP2	O		<b>Device Access Port Line 2</b>
<b>Power Supply</b>				
R2	$V_{DDM}$	-	-	<b>ADC Analog Part Power Supply (3.3V - 5V)</b>
R1	$V_{SSM}$	-	-	<b>ADC Analog Part Ground</b>
Y6	$V_{AREF0}$	-	-	<b>ADC0 Reference Voltage</b>
W6	$V_{AREF1}$	-	-	<b>ADC1 Reference Voltage</b>
W7	$V_{AREF2}$	-	-	<b>ADC2 Reference Voltage</b>
Y7	$V_{AGND0}$	-	-	<b>ADC0 Reference Ground</b>
	$V_{AGND1}$	-	-	<b>ADC1 Reference Ground</b>
	$V_{AGND2}$	-	-	<b>ADC2 Reference Ground</b>
U10	$V_{FAREF}$	-	-	<b>FADC Reference Voltage</b>
W10	$V_{FAGND}$	-	-	<b>FADC Reference Ground</b>
U11	$V_{DDMF}$	-	-	<b>FADC Analog Part Power Supply (3.3V)</b>
T11	$V_{DDAF}$	-	-	<b>FADC Analog Part Logic Power Supply (1.3V)</b>
Y10	$V_{SSMF}$	-	-	<b>FADC Analog Part Ground</b>
	$V_{SSAF}$	-	-	<b>FADC Analog Part Logic Ground</b>

## Pinning TC1791 Pin Configuration

**Table 2 Pin Definitions and Functions (cont'd)**

Pin	Symbol	Ctrl.	Type	Function
K5, L16	$V_{DDFL3}$	-	-	<b>Flash Power Supply (3.3V)</b>
J20	$V_{SSOSC}$	-	-	<b>Oscillator Ground (Main &amp; E-Ray)</b>
	$V_{SSOSC3}$	-	-	<b>Oscillator Ground (Main &amp; E-Ray)</b>
J19	$V_{DDOSC}$	-	-	<b>Main Oscillator Power Supply (1.3V)</b>
K16	$V_{DDOSC3}$	-	-	<b>Main Oscillator Power Supply (3.3V)</b>
K17	$V_{DDPF}$	-	-	<b>E-Ray PLL Power Supply (1.3V)</b>
L17	$V_{DDPF3}$	-	-	<b>E-Ray PLL Power Supply (3.3V)</b>
G8, G13, H7, H14, N7, N14, P8, P13, R16, T17, V19, W20	$V_{DD}$	-	-	<b>Digital Core Power Supply (1.3V)</b>
A2, A19, B3, B10, B18, K2, M19, M20, W11, W17	$V_{DDP}$	-	-	<b>Port Power Supply (3.3V)</b>
L4, L5	$V_{DDSB}$	-	-	<b>Emulation Stand-by SRAM Power Supply (1.3V) (Emulation device only)</b> <i>Note: This pin is N.C. in a productive device.</i>

## Pinning TC1791 Pin Configuration

**Table 2 Pin Definitions and Functions (cont'd)**

Pin	Symbol	Ctrl.	Type	Function
P9, P10, P11, P12, N9, N10, N11, N12	$V_{SS}$	-	-	<b>Digital Ground (center balls)</b>
M7, M8, M10, M11, M13, M14, J7, J8, J10, J11, J13, J14	$V_{SS}$	-	-	<b>Digital Ground (center balls cont'd)</b>
L7, L8, L9, L10, L11, L12, L13, L14	$V_{SS}$	-	-	<b>Digital Ground (center balls cont'd)</b>
K7, K8, K9, K10, K11, K12, K13, K14	$V_{SS}$	-	-	<b>Digital Ground (center balls cont'd)</b>

## Pinning TC1791 Pin Configuration

**Table 2 Pin Definitions and Functions (cont'd)**

Pin	Symbol	Ctrl.	Type	Function
G9, G10, G11, G12, H9, H10, H11, H12	$V_{SS}$	-	-	<b>Digital Ground (center balls cont'd)</b>
T16, U17, W19	$V_{SS}$	-	-	<b>Digital Ground (outer balls)</b>
L19, L20, Y17, Y20	$V_{SS}$	-	-	<b>Digital Ground (outer balls)</b>
A10, A20, B2, B19, D4, D17, E5, E16, K1, Y11	$V_{SS}$	-	-	<b>Digital Ground (outer balls)</b>
A1, Y1	N.C.	-	-	<b>Not connected.</b> These pins are reserved for future extension and shall not be connected externally.

- 1) Only applicable in TC1791ED. Reserved in TC1791PD.
- 2) Only available for SAK-TC1791S-512F240EP, SAK-TC1791F-512F240EP, SAK-TC1791F-512F240EL, SAK-TC1791S-384F200EP, SAK-TC1791F-384F200EP, and SAK-TC1791F-384F200EL.
- 3) The MTSR output of SSCx is overlaid with the MRSTG input of the related SSCGx
- 4) Analog Input overlaid with a SENT Digital Input. The related port logic is used to configure the input as either analog input (default after reset) or digital input. The related port logic supports only the port input features as the connected pads are input pads only.
- 5) IOZ1 valid for this pin is the parameter with overlaid = No in the ADC parameter table.
- 6) IOZ1 valid for this pin is the parameter with overlaid = Yes in the ADC parameter table.



**Legend for Table 2**Column “**Ctrl.**”:I = Input (for GPIO port lines with IOCR bit field selection  $PCx = 0XXX_B$ )

O = Output

O0 = Output with IOCR bit field selection  $PCx = 1X00_B$ O1 = Output with IOCR bit field selection  $PCx = 1X01_B$  (ALT1)O2 = Output with IOCR bit field selection  $PCx = 1X10_B$  (ALT2)O3 = Output with IOCR bit field selection  $PCx = 1X11_B$  (ALT3)Column “**Type**”:

A1 = Pad class A1 (LVTTTL)

A1+ = Pad class A1+ (LVTTTL)

A2 = Pad class A2 (LVTTTL)

F = Pad class F (LVDS/CMOS)

D = Pad class D (ADC)

S = Pad class S (SENT)

PU = with pull-up device connected during reset ( $\overline{PORST} = 0$ )PD = with pull-down device connected during reset ( $PORST = 0$ )TR = tri-state during reset ( $\overline{PORST} = 0$ )

## 4 Identification Registers

The Identification Registers uniquely identify the whole device.

**Table 3 SAK-TC1791F-512F240EL Identification Registers**

Short Name	Value	Address	Stepping
CBS_JDPID	0000 6350 <sub>H</sub>	F000 0408 <sub>H</sub>	AB
CBS_JTAGID	1018 E083 <sub>H</sub>	F000 0464 <sub>H</sub>	AB
SCU_CHIPID	0700 9502 <sub>H</sub>	F000 0640 <sub>H</sub>	AB
SCU_MANID	0000 1820 <sub>H</sub>	F000 0644 <sub>H</sub>	AB
SCU_RTID	0000 0000 <sub>H</sub>	F000 0648 <sub>H</sub>	AB

**Table 4 SAK-TC1791F-512F240EP Identification Registers**

Short Name	Value	Address	Stepping
CBS_JDPID	0000 6350 <sub>H</sub>	F000 0408 <sub>H</sub>	AB
CBS_JTAGID	1018 E083 <sub>H</sub>	F000 0464 <sub>H</sub>	AB
SCU_CHIPID	8700 9502 <sub>H</sub>	F000 0640 <sub>H</sub>	AB
SCU_MANID	0000 1820 <sub>H</sub>	F000 0644 <sub>H</sub>	AB
SCU_RTID	0000 0000 <sub>H</sub>	F000 0648 <sub>H</sub>	AB

**Table 5 SAK-TC1791F-512F200EL Identification Registers**

Short Name	Value	Address	Stepping
CBS_JDPID	0000 6350 <sub>H</sub>	F000 0408 <sub>H</sub>	AB
CBS_JTAGID	1018 E083 <sub>H</sub>	F000 0464 <sub>H</sub>	AB
SCU_CHIPID	1700 9502 <sub>H</sub>	F000 0640 <sub>H</sub>	AB
SCU_MANID	0000 1820 <sub>H</sub>	F000 0644 <sub>H</sub>	AB
SCU_RTID	0000 0000 <sub>H</sub>	F000 0648 <sub>H</sub>	AB

**Table 6 SAK-TC1791F-512F200EP Identification Registers**

Short Name	Value	Address	Stepping
CBS_JDPID	0000 6350 <sub>H</sub>	F000 0408 <sub>H</sub>	AB
CBS_JTAGID	1018 E083 <sub>H</sub>	F000 0464 <sub>H</sub>	AB
SCU_CHIPID	9700 9502 <sub>H</sub>	F000 0640 <sub>H</sub>	AB

**Identification Registers**
**Table 6 SAK-TC1791F-512F200EP Identification Registers (cont'd)**

Short Name	Value	Address	Stepping
SCU_MANID	0000 1820 <sub>H</sub>	F000 0644 <sub>H</sub>	AB
SCU_RTID	0000 0000 <sub>H</sub>	F000 0648 <sub>H</sub>	AB

**Table 7 SAK-TC1791F-384F200EL Identification Registers**

Short Name	Value	Address	Stepping
CBS_JDPID	0000 6350 <sub>H</sub>	F000 0408 <sub>H</sub>	AB
CBS_JTAGID	1018 E083 <sub>H</sub>	F000 0464 <sub>H</sub>	AB
SCU_CHIPID	1600 9502 <sub>H</sub>	F000 0640 <sub>H</sub>	AB
SCU_MANID	0000 1820 <sub>H</sub>	F000 0644 <sub>H</sub>	AB
SCU_RTID	0000 0000 <sub>H</sub>	F000 0648 <sub>H</sub>	AB

**Table 8 SAK-TC1791F-384F200EP Identification Registers**

Short Name	Value	Address	Stepping
CBS_JDPID	0000 6350 <sub>H</sub>	F000 0408 <sub>H</sub>	AB
CBS_JTAGID	1018 E083 <sub>H</sub>	F000 0464 <sub>H</sub>	AB
SCU_CHIPID	9600 9502 <sub>H</sub>	F000 0640 <sub>H</sub>	AB
SCU_MANID	0000 1820 <sub>H</sub>	F000 0644 <sub>H</sub>	AB
SCU_RTID	0000 0000 <sub>H</sub>	F000 0648 <sub>H</sub>	AB

**Table 9 SAK-TC1791S-512F240EP Identification Registers**

Short Name	Value	Address	Stepping
CBS_JDPID	0000 6350 <sub>H</sub>	F000 0408 <sub>H</sub>	AB
CBS_JTAGID	1018 E083 <sub>H</sub>	F000 0464 <sub>H</sub>	AB
SCU_CHIPID	8700 AA02 <sub>H</sub>	F000 0640 <sub>H</sub>	AB
SCU_MANID	0000 1820 <sub>H</sub>	F000 0644 <sub>H</sub>	AB
SCU_RTID	0000 0000 <sub>H</sub>	F000 0648 <sub>H</sub>	AB

Identification Registers

**Table 10 SAK-TC1791S-384F200EP Identification Registers**

Short Name	Value	Address	Stepping
CBS_JDPID	0000 6350 <sub>H</sub>	F000 0408 <sub>H</sub>	AB
CBS_JTAGID	1018 E083 <sub>H</sub>	F000 0464 <sub>H</sub>	AB
SCU_CHIPID	9600 AA02 <sub>H</sub>	F000 0640 <sub>H</sub>	AB
SCU_MANID	0000 1820 <sub>H</sub>	F000 0644 <sub>H</sub>	AB
SCU_RTID	0000 0000 <sub>H</sub>	F000 0648 <sub>H</sub>	AB

**Table 11 SAK-TC1791N-384F200EP Identification Registers**

Short Name	Value	Address	Stepping
CBS_JDPID	0000 6350 <sub>H</sub>	F000 0408 <sub>H</sub>	AB
CBS_JTAGID	1018 E083 <sub>H</sub>	F000 0464 <sub>H</sub>	AB
SCU_CHIPID	9600 B502 <sub>H</sub>	F000 0640 <sub>H</sub>	AB
SCU_MANID	0000 1820 <sub>H</sub>	F000 0644 <sub>H</sub>	AB
SCU_RTID	0000 0000 <sub>H</sub>	F000 0648 <sub>H</sub>	AB

## **5 Electrical Parameters**

This specification provides all electrical parameters of the TC1791.

### **5.1 General Parameters**

#### **5.1.1 Parameter Interpretation**

The parameters listed in this section partly represent the characteristics of the TC1791 and partly its requirements on the system. To aid interpreting the parameters easily when evaluating them for a design, they are marked with an two-letter abbreviation in column "Symbol":

- **CC**  
Such parameters indicate **C**ontroller **C**haracteristics which are a distinctive feature of the TC1791 and must be regarded for a system design.
- **SR**  
Such parameters indicate **S**ystem **R**equirements which must provided by the microcontroller system in which the TC1791 designed in.

## Electrical Parameters General Parameters

## 5.1.2 Pad Driver and Pad Classes Summary

This section gives an overview on the different pad driver classes and its basic characteristics. More details (mainly DC parameters) are defined in the [Section 5.2.1](#).

Table 12 Pad Driver and Pad Classes Overview

Class	Power Supply	Type	Sub Class	Speed Grade <sup>1)</sup>	Load <sup>1)</sup>	Leakage 150°C <sup>1)</sup>	Termination
A	3.3 V	LVTTL I/O, LVTTL outputs	A1 (e.g. GPIO)	6 MHz	100 pF	500 nA	No
			A1+ (e.g. serial I/Os)	25 MHz	50 pF	1 μA	Series termination recommended
			A2 (e.g. serial I/Os)	40 MHz	50 pF	3 μA	Series termination recommended
F	3.3 V	LVDS	–	50 MHz	–	–	Parallel termination, 100 Ω ± 10% <sup>2)</sup>
		CMOS	–	6 MHz	50 pF	–	
D <sub>E</sub>	5 V	ADC	–	–	–	–	
I	3.3 V	LVTTL (input only)	–	–	–	–	

1) These values show typical application configurations for the pad. Complete and detailed pad parameters are available in the individual pad parameter table on the following pages.

2) In applications where the LVDS pins are not used (disabled), these pins must be either left unconnected, or properly terminated with the differential parallel termination of 100 Ω ± 10%.

## Electrical Parameters General Parameters

**5.1.3 Absolute Maximum Ratings**

Stresses above the values listed under “Absolute Maximum Ratings” may cause permanent damage to the device. This is a stress rating only and functional operation of the device at these or any other conditions above those indicated in the operational sections of this specification is not implied. Exposure to absolute maximum rating conditions may affect device reliability.

**Table 13 Absolute Maximum Rating Parameters**

Parameter	Symbol	Values			Unit	Note / Test Condition
		Min.	Typ.	Max.		
Storage temperature	$T_{ST}$ SR	-65	–	150	°C	–
Voltage at 1.3 V power supply pins with respect to $V_{SS}$	$V_{DD}$ SR	–	–	2.0	V	–
Voltage at 3.3 V power supply pins with respect to $V_{SS}$	$V_{DDP}$ SR	–	–	4.33	V	–
Voltage at 5 V power supply pins with respect to $V_{SS}$	$V_{DDM}$ SR	–	–	7.0	V	–
Voltage on any Class A input pin and dedicated input pins with respect to $V_{SS}$	$V_{IN}$ SR	-0.7	–	$V_{DDP} + 0.5$ or max. 4.33	V	Whatever is lower
Voltage on any Class D analog input pin with respect to $V_{AGND}$	$V_{AIN}$ $V_{AREF_x}$ SR	-0.6	–	7.0	V	–
Voltage on any shared Class D analog input pin with respect to $V_{SSAF}$ , if the FADC is switched through to the pin.	$V_{AINF}$ $V_{FAREF}$ SR	-0.6	–	7.0	V	–
Input current on any pin during overload condition	$I_{IN}$	-10	–	+10	mA	
Absolute maximum sum of all input circuit currents for one port group during overload condition <sup>1)</sup>	$I_{IN}$	-25	–	+25	mA	
Absolute maximum sum of all input circuit currents during overload condition	$\Sigma I_{IN}$	-200	–	200	mA	

1) The port groups are defined in [Table 18](#).

### 5.1.4 Pin Reliability in Overload

When receiving signals from higher voltage devices, low-voltage devices experience overload currents and voltages that go beyond their own IO power supplies specification.

**Table 14** defines overload conditions that will not cause any negative reliability impact if all the following conditions are met:

- full operation life-time (24000 h) is not exceeded
- **Operating Conditions** are met for
  - pad supply levels ( $V_{DDP}$  or  $V_{DDM}$ )
  - temperature

If a pin current is out of the **Operating Conditions** but within the overload parameters, then the parameters functionality of this pin as stated in the Operating Conditions can no longer be guaranteed. Operation is still possible in most cases but with relaxed parameters.

*Note: An overload condition on one or more pins does not require a reset.*

**Table 14** Overload Parameters

Parameter	Symbol	Values			Unit	Note / Test Condition
		Min.	Typ.	Max.		
Input current on any digital pin during overload condition except LVDS pins	$I_{IN}$	-5	–	+5	mA	
Input current on LVDS pins	$I_{INLVDS}$	-3	–	+3	mA	
Absolute sum of all input circuit currents for one port group during overload condition <sup>1)</sup>	$I_{ING}$	-20	–	+20	mA	
Input current on analog pins	$I_{INANA}$	-3	–	+3	mA	
Absolute sum of all analog input currents for analog inputs during overload condition	$I_{INSA}$	-45	–	+45	mA	
Absolute sum of all input circuit currents during overload condition	$\Sigma I_{INS}$	-100	–	100	mA	

1) The port groups are defined in **Table 18**.

*Note: FADC input pins count as analog pin as they are overlaid with an ADC pins.*



## Electrical Parameters General Parameters

**Table 15 PN-Junction Characteristics for positive Overload**

Pad Type	$I_{IN} = 3 \text{ mA}$	$I_{IN} = 5 \text{ mA}$
A1 / A1+ / F	$U_{IN} = V_{DDP} + 0.6 \text{ V}$	$U_{IN} = V_{DDP} + 0.7 \text{ V}$
A2	$U_{IN} = V_{DDP} + 0.5 \text{ V}$	$U_{IN} = V_{DDP} + 0.6 \text{ V}$
LVDS	$U_{IN} = V_{DDP} + 0.7 \text{ V}$	-
D	$U_{IN} = V_{DDM} + 0.6 \text{ V}$	-
S	$U_{IN} = V_{DDM} + 0.6 \text{ V}$	-

**Table 16 PN-Junction Characteristics for negative Overload**

Pad Type	$I_{IN} = -3 \text{ mA}$	$I_{IN} = -5 \text{ mA}$
A1 / A1+ / F	$U_{IN} = V_{SS} - 0.6 \text{ V}$	$U_{IN} = V_{SS} - 0.7 \text{ V}$
A2	$U_{IN} = V_{SS} - 0.5 \text{ V}$	$U_{IN} = V_{SS} - 0.6 \text{ V}$
LVDS	$U_{IN} = V_{SS} - 0.7 \text{ V}$	-
D	$U_{IN} = V_{SSM} - 0.6 \text{ V}$	-
S	$U_{IN} = V_{SSM} - 0.6 \text{ V}$	-

*Note: A series resistor at the pin to limit the current to the maximum permitted overload current is sufficient to handle failure situations like short to battery without having any negative reliability impact on the operational life-time.*

### 5.1.5 Operating Conditions

The following operating conditions must not be exceeded in order to ensure correct operation and reliability of the TC1791. All parameters specified in the following tables refer to these operating conditions, unless otherwise noticed.

Digital supply voltages applied to the TC1791 must be static regulated voltages which allow a typical voltage swing of  $\pm 5\%$ .

All parameters specified in the following tables ([Table 19](#) and following) refer to these operating conditions ([Table 17](#)), unless otherwise noticed in the Note / Test Condition column.

The [Extended Range Operating Conditions](#) did not increase area of validity of the parameters defined in table 11 and later.

**Table 17 Operating Conditions Parameters**

Parameter	Symbol	Values			Unit	Note / Test Condition
		Min.	Typ.	Max.		
Overload coupling factor for analog inputs, negative	$K_{OVAN}$ CC	–	–	0.0001		$I_{OV} \leq 0$ mA; $I_{OV} \geq -2$ mA; analog pad= 5.0 V
Overload coupling factor for analog inputs, positive	$K_{OVAP}$ CC	–	–	0.0000 1		$I_{OV} \leq 3$ mA; $I_{OV} \geq 0$ mA; analog pad= 5.0 V

**Electrical Parameters General Parameters**
**Table 17 Operating Conditions Parameters (cont'd)**

Parameter	Symbol	Values			Unit	Note / Test Condition
		Min.	Typ.	Max.		
CPU Frequency	$f_{\text{CPU SR}}$	–	–	240	MHz	SAK-TC1791F-512F 240EL; SAK-TC1791F-512F 240EP; SAK-TC1791S-512F 240EP
		–	–	200	MHz	SAK-TC1791F-512F 200EL SAK-TC1791F-512F 200EP; SAK-TC1791F-384F 200EL; SAK-TC1791F-384F 200EP; SAK-TC1791S-384F 200EP; SAK-TC1791F-384N 200EL; SAK-TC1791F-384N 200EP

**Electrical Parameters General Parameters**
**Table 17 Operating Conditions Parameters (cont'd)**

Parameter	Symbol	Values			Unit	Note / Test Condition
		Min.	Typ.	Max.		
Modulated $f_{CPU}$	$f_{CPU\_modulated}$ SR	–	–	240	MHz	SAK-TC1791F-512F 240EL; SAK-TC1791F-512F 240EP; SAK-TC1791S-512F 240EP
		–	–	200	MHz	SAK-TC1791F-512F 200EL SAK-TC1791F-512F 200EP; SAK-TC1791F-384F 200EL; SAK-TC1791F-384F 200EP; SAK-TC1791S-384F 200EP; SAK-TC1791F-384N 200EL; SAK-TC1791F-384N 200EP
FPI bus frequency	$f_{FPI}$ SR	–	–	100	MHz	
Modulated $f_{FPI}$	$f_{FPI\_modulated}$ SR	–	–	100-2*MA <sup>1)</sup>	MHz	MA = modulation amplitude
FSI frequency	$f_{FSI}$ SR	–	–	150	MHz	
Modulated $f_{FSI}$	$f_{FSI\_modulated}$ SR	–	–	150-2*MA <sup>1)</sup>	MHz	MA = modulation amplitude
PCP Frequency	$f_{PCP}$ SR	–	–	200	MHz	
Modulated $f_{PCP}$	$f_{PCP\_modulated}$ SR	–	–	200-2*MA <sup>1)</sup>	MHz	MA = modulation amplitude

**Electrical Parameters General Parameters**
**Table 17 Operating Conditions Parameters (cont'd)**

Parameter	Symbol	Values			Unit	Note / Test Condition
		Min.	Typ.	Max.		
SRI Frequency	$f_{SRI}$ SR	–	–	240	MHz	SAK-TC1791F-512F 240EL; SAK-TC1791F-512F 240EP; SAK-TC1791S-512F 240EP
		–	–	200	MHz	SAK-TC1791F-512F 200EL SAK-TC1791F-512F 200EP; SAK-TC1791F-384F 200EL; SAK-TC1791F-384F 200EP; SAK-TC1791S-384F 200EP; SAK-TC1791F-384N 200EL; SAK-TC1791F-384N 200EP

## Electrical Parameters General Parameters

Table 17 Operating Conditions Parameters (cont'd)

Parameter	Symbol	Values			Unit	Note / Test Condition
		Min.	Typ.	Max.		
Modulated $f_{\text{SRI}}$	$f_{\text{SRI\_modulated SR}}$	–	–	240	MHz	SAK-TC1791F-512F 240EL; SAK-TC1791F-512F 240EP; SAK-TC1791S-512F 240EP
		–	–	200	MHz	SAK-TC1791F-512F 200EL SAK-TC1791F-512F 200EP; SAK-TC1791F-384F 200EL; SAK-TC1791F-384F 200EP; SAK-TC1791S-384F 200EP; SAK-TC1791F-384N 200EL; SAK-TC1791F-384N 200EP
Inactive device pin current	$I_{\text{ID SR}}$	-1	–	1	mA	All power supply voltages $V_{\text{DDx}} = 0$
Short circuit current of digital outputs <sup>2)</sup>	$I_{\text{SC SR}}$	-5	–	5	mA	
Absolute sum of short circuit currents of the device	$\Sigma I_{\text{SC\_D CC}}$	–	–	100	mA	
Absolute sum of short circuit currents per pin group	$\Sigma I_{\text{SC\_PG CC}}$	–	–	20	mA	
Ambient Temperature	$T_{\text{A SR}}$	-40	–	125	°C	
Junction temperature	$T_{\text{J SR}}$	-40	–	150	°C	
Core Supply Voltage	$V_{\text{DD SR}}$	1.17	1.3	1.43 <sup>3)</sup>	V	for duration limitation see <a href="#">Section 5.1.5.1</a>

## Electrical Parameters General Parameters

Table 17 Operating Conditions Parameters (cont'd)

Parameter	Symbol	Values			Unit	Note / Test Condition
		Min.	Typ.	Max.		
Flash supply voltage 3.3V	$V_{DDFL3}$ SR	2.97	3.3	3.63 <sup>5)</sup>	V	for duration limitation see <a href="#">Section 5.1.5.1</a>
ADC analog supply voltage	$V_{DDM}$ SR	3.135	5	5.5 <sup>4)</sup>	V	
Oscillator core supply voltage	$V_{DDOSC}$ SR	1.17	1.3	1.43 <sup>3)</sup>	V	for duration limitation see <a href="#">Section 5.1.5.1</a>
Oscillator 3.3V supply voltage	$V_{DDOSC3}$ SR	2.97	3.3	3.63 <sup>5)</sup>	V	for duration limitation see <a href="#">Section 5.1.5.1</a>
Digital supply voltage for IO pads	$V_{DDP}$ SR	2.97	3.3	3.63 <sup>5)</sup>	V	for duration limitation see <a href="#">Section 5.1.5.1</a>
E-Ray PLL core voltage supply	$V_{DDPF}$ SR	1.17	1.3	1.43 <sup>3)</sup>	V	for duration limitation see <a href="#">Section 5.1.5.1</a>
E-Ray PLL 3.3V supply	$V_{DDPF3}$ SR	2.97	3.3	3.63 <sup>5)</sup>	V	for duration limitation see <a href="#">Section 5.1.5.1</a>
VDDP voltage to ensure defined pad states <sup>6)</sup>	$V_{DDPPA}$ CC	0.65	–	–	V	
Digital ground voltage	$V_{SS}$ SR	0	–	–	V	
Analog ground voltage for $V_{DDM}$	$V_{SSM}$ SR	-0.1	0	0.1	V	
Analog core supply	$V_{DDAF}$ SR	1.17	1.3	1.43 <sup>3)</sup>	V	
FADC / ADC analog supply voltage	$V_{DDMF}$ SR	2.97	3.3	3.63 <sup>5)</sup>	V	
Analog ground voltage for $V_{DDMF}$	$V_{SSAF}$ SR	-0.1	0	0.1	V	

1) MA equals the modulation amplitude in percentage times the configured PLL clock out frequency.

2) Applicable for digital outputs.

3) Voltage overshoot to 1.7V is permissible at Power-Up and  $\overline{\text{PORST}}$  low, provided the pulse duration is less than 100  $\mu\text{s}$  and the cumulated sum of the pulses does not exceed 1 h.

## Electrical Parameters General Parameters

- 4) Voltage overshoot to 6.5V is permissible at Power-Up and  $\overline{\text{PORST}}$  low, provided the pulse duration is less than 100  $\mu\text{s}$  and the cumulated sum of the pulses does not exceed 1 h.
- 5) Voltage overshoot to 4.0V is permissible at Power-Up and  $\overline{\text{PORST}}$  low, provided the pulse duration is less than 100  $\mu\text{s}$  and the cumulated sum of the pulses does not exceed 1 h.
- 6) This parameter is valid under the assumption the  $\overline{\text{PORST}}$  signal is constantly at low level during the power-up/power-down of  $V_{\text{DDP}}$ .

### 5.1.5.1 Extended Range Operating Conditions

The following extended operating conditions are defined:

- $1.3\text{V} + 5\% < V_{\text{DD}} / V_{\text{DDOSC}} / V_{\text{DDPF}} / V_{\text{DDAF}} < 1.3\text{V} + 7.5\%$  (overvoltage condition):
  - limited to 10000 hour duration cumulative in lifetime, due to the reliability reduction of the chip caused by the overvoltage stress.
- $1.3\text{V} + 7.5\% < V_{\text{DD}} / V_{\text{DDOSC}} / V_{\text{DDPF}} / V_{\text{DDAF}} < 1.3\text{V} + 10\%$  (overvoltage condition):
  - limited to 1000 hours duration cumulative in lifetime, due to the reliability reduction of the chip caused by the overvoltage stress.
- $3.3\text{V} + 5\% < V_{\text{DDP}} / V_{\text{DDOSC3}} / V_{\text{DDPF3}} / V_{\text{DDFL3}} / V_{\text{DDMF}} < 3.3\text{V} + 10\%$  (overvoltage condition):
  - limited to 1000 hours duration cumulative in lifetime, due to the reliability reduction of the chip caused by the overvoltage stress.

**Table 18 Pin Groups for Overload / Short-Circuit Current Sum Parameter**

Group	Pins
1	P2.[4:2], P6.[6:9]
2	P6.[5:4], P6.[11:10]
3	P6.[15:12]
4	P8.[5:0]
5	P8.[7:6]
6	P1.7, P1.9
7	P1.6, P1.12
8	P1.[1:0], P7.[2:0]
9	P7.[5:3]
10	P4.[6:0]
11	P4.[10:7]
12	P4.12, P4.14
13	P10.[5:0]
14	P14.8



**Table 18 Pin Groups for Overload / Short-Circuit Current Sum Parameter**

Group	Pins
15	P14.4, P14.6
16	P13.15, P14.0, P14.2
17	P13.[14:11]
18	P13.[10:8]
19	P13.[7:4]
20	P13.[3:0]
21	P9.10, P9.14
22	P9.7, P9.13
23	P9.[4:2], P9.6
24	P9.1, P9.5, P9.8
25	P9.0
26	P5.[11:8]
27	P5.6, P5.[15:12]
28	P5.0, P5.[5:2], P5.7
29	P3.0, P3.4, P5.1
30	P3.10, P3.12
31	P0.[3:0]
32	P0.[11:4]
33	P0.[14:12]
34	P2:12, P2.14
35	P2.[10:5]

## Electrical Parameters DC Parameters

## 5.2 DC Parameters

## 5.2.1 Input/Output Pins

Table 19 Standard\_Pads Parameters

Parameter	Symbol	Values			Unit	Note / Test Condition
		Min.	Typ.	Max.		
Pin capacitance (digital inputs/outputs)	$C_{IO}$ CC	–	–	10	pF	$T_A = 25\text{ }^\circ\text{C}$ ; $f = 1\text{ MHz}$
Pull-down current	$ I_{PDL} $ CC	–	–	150	$\mu\text{A}$	$V_I \geq 0.6 \times V_{DDP}$ V
		10	–	–	$\mu\text{A}$	$V_I \geq 0.36 \times V_{DDP}$ V
Pull-Up current	$ I_{PUH} $ CC	10	–	–	$\mu\text{A}$	$V_I \leq 0.6 \times V_{DDP}$ V
		–	–	100	$\mu\text{A}$	$V_I \leq 0.36 \times V_{DDP}$ V
Spike filter always blocked pulse duration	$t_{SF1}$ CC	–	–	10	ns	only PORST pin
Spike filter pass-through pulse duration	$t_{SF2}$ CC	100	–	–	ns	only PORST pin

Table 20 Standard\_Pads Class\_A1

Parameter	Symbol	Values			Unit	Note / Test Condition
		Min.	Typ.	Max.		
Input Hysteresis for A1 pads <sup>1)</sup>	$HYS_{A1}$ CC	$0.1 \times V_{DDP}$	–	–	V	
Input Leakage Current Class A1	$I_{OZA1}$ CC	-500	–	500	nA	$V_I \geq 0\text{ V}$ ; $V_I \leq V_{DDP}$ V
Ratio $V_{IH1}/V_{IL1}$ , A1 pads	$V_{ILA1} / V_{IHA1}$ CC	0.6	–	–		
On-Resistance of the class A1 pad, weak driver	$R_{DSONW}$ CC	–	450	600	Ohm	$I_{OH} > -0.5\text{ mA}$ ; P_MOS
		–	210	340	Ohm	$I_{OL} < 0.5\text{ mA}$ ; N_MOS

## Electrical Parameters DC Parameters

Table 20 Standard\_Pads Class\_A1 (cont'd)

Parameter	Symbol	Values			Unit	Note / Test Condition
		Min.	Typ.	Max.		
On-Resistance of the class A1 pad, medium driver	$R_{DSONM}$ CC	–	–	155	Ohm	$I_{OH} > -2$ mA; P_MOS
		–	–	110	Ohm	$I_{OL} < 2$ mA; N_MOS
Fall time, pad type A1	$t_{FA1}$ CC	–	–	150	ns	$C_L = 20$ pF; pin out driver= weak
		–	–	50	ns	$C_L = 50$ pF; pin out driver= medium
		–	–	140	ns	$C_L = 150$ pF; pin out driver= medium
		–	–	550	ns	$C_L = 150$ pF; pin out driver= weak
		–	–	18000	ns	$C_L = 20000$ pF; pin out driver= medium
		–	–	65000	ns	$C_L = 20000$ pF; pin out driver= weak

## Electrical Parameters DC Parameters

Table 20 Standard\_Pads Class\_A1 (cont'd)

Parameter	Symbol	Values			Unit	Note / Test Condition
		Min.	Typ.	Max.		
Rise time, pad type A1	$t_{RA1}$ CC	–	–	150	ns	$C_L = 20$ pF; pin out driver= weak
		–	–	50	ns	$C_L = 50$ pF; pin out driver= medium
		–	–	140	ns	$C_L = 150$ pF; pin out driver= medium
		–	–	550	ns	$C_L = 150$ pF; pin out driver= weak
		–	–	18000	ns	$C_L = 20000$ pF; pin out driver= medium
		–	–	65000	ns	$C_L = 20000$ pF; pin out driver= weak
Input high voltage class A1 pads	$V_{IHA1}$ SR	$0.6 \times V_{DDP}$	–	$\min(V_{DDP} + 0.3, 3.6)$	V	
Input low voltage class A1 pads	$V_{ILA1}$ SR	-0.3	–	$0.36 \times V_{DDP}$	V	

## Electrical Parameters DC Parameters

**Table 20 Standard\_Pads Class\_A1 (cont'd)**

Parameter	Symbol	Values			Unit	Note / Test Condition
		Min.	Typ.	Max.		
Output voltage high class A1 pads	$V_{\text{OHA1}}$ CC	$V_{\text{DDP}} - 0.4$	–	–	V	$I_{\text{OH}} \geq -1.4$ mA; pin out driver= medium
		2.4	–	–	V	$I_{\text{OH}} \geq -2$ mA; pin out driver= medium
		$V_{\text{DDP}} - 0.4$	–	–	V	$I_{\text{OH}} \geq -400$ $\mu$ A; pin out driver= weak
		2.4	–	–	V	$I_{\text{OH}} \geq -500$ $\mu$ A; pin out driver= weak
Output voltage low class A1 pads	$V_{\text{OLA1}}$ CC	–	–	0.4	V	$I_{\text{OL}} \leq 2$ mA; pin out driver= medium
		–	–	0.4	V	$I_{\text{OL}} \leq 500$ $\mu$ A; pin out driver= weak

1) Hysteresis is implemented to avoid metastable states and switching due to internal ground bounce. It can't be guaranteed that it suppresses switching due to external system noise.

**Table 21 Standard\_Pads Class\_A1+**

Parameter	Symbol	Values			Unit	Note / Test Condition
		Min.	Typ.	Max.		
Input Hysteresis for A1+ pads <sup>1)</sup>	$H_{\text{YSA1}}$ + CC	$0.1 \times V_{\text{DDP}}$	–	–	V	
Input Leakage Current Class A1+	$I_{\text{OZA1+}}$ CC	-1000	–	1000	nA	
On-Resistance of the class A1+ pad, weak driver	$R_{\text{DSONW}}$ CC	–	450	600	Ohm	$I_{\text{OH}} > -0.5$ mA; P_MOS
		–	210	340	Ohm	$I_{\text{OL}} < 0.5$ mA; N_MOS

## Electrical Parameters DC Parameters

Table 21 Standard\_Pads Class\_A1+ (cont'd)

Parameter	Symbol	Values			Unit	Note / Test Condition
		Min.	Typ.	Max.		
On-Resistance of the class A1+ pad, medium driver	$R_{DSONM}$ CC	–	–	155	Ohm	$I_{OH} > -2$ mA; P_MOS
		–	–	110	Ohm	$I_{OL} < 2$ mA; N_MOS
On-Resistance of the class A1+ pad, strong driver	$R_{DSON1+}$ CC	–	–	100	Ohm	$I_{OH} > -2$ mA; P_MOS
		–	–	80	Ohm	$I_{OL} < 2$ mA; N_MOS
Fall time, pad type A1+	$t_{FA1+}$ CC	–	–	150	ns	$C_L = 20$ pF; pin out driver= weak
		–	–	28	ns	$C_L = 50$ pF; edge= slow ; pin out driver= strong
		–	–	16	ns	$C_L = 50$ pF; edge= soft ; pin out driver= strong
		–	–	50	ns	$C_L = 50$ pF; pin out driver= medium
		–	–	140	ns	$C_L = 150$ pF; pin out driver= medium
		–	–	550	ns	$C_L = 150$ pF; pin out driver= weak
		–	–	18000	ns	$C_L = 20000$ pF; pin out driver= medium
		–	–	65000	ns	$C_L = 20000$ pF; pin out driver= weak
		–	–			

## Electrical Parameters DC Parameters

Table 21 Standard\_Pads Class\_A1+ (cont'd)

Parameter	Symbol	Values			Unit	Note / Test Condition
		Min.	Typ.	Max.		
Rise time, pad type A1+	$t_{RA1+}$ CC	–	–	150	ns	$C_L = 20$ pF; pin out driver= weak
		–	–	28	ns	$C_L = 50$ pF; edge= slow ; pin out driver= strong
		–	–	16	ns	$C_L = 50$ pF; edge= soft ; pin out driver= strong
		–	–	50	ns	$C_L = 50$ pF; pin out driver= medium
		–	–	140	ns	$C_L = 150$ pF; pin out driver= medium
		–	–	550	ns	$C_L = 150$ pF; pin out driver= weak
		–	–	18000	ns	$C_L = 20000$ pF; pin out driver= medium
		–	–	65000	ns	$C_L = 20000$ pF; pin out driver= weak
Input high voltage, Class A1+ pads	$V_{IHA1+}$ SR	$0.6 \times V_{DDP}$	–	$\min(V_{DDP} + 0.3, 3.6)$	V	
Input low voltage Class A1+ pads	$V_{ILA1+}$ SR	-0.3	–	$0.36 \times V_{DDP}$	V	
Ratio $V_{il}/V_{ih}$ , A1+ pads	$V_{ILA1+} / V_{IHA1+}$ CC	0.6	–	–		

## Electrical Parameters DC Parameters

Table 21 Standard\_Pads Class\_A1+ (cont'd)

Parameter	Symbol	Values			Unit	Note / Test Condition
		Min.	Typ.	Max.		
Output voltage high class A1+ pads	$V_{\text{OHA1+CC}}$	$V_{\text{DDP}} - 0.4$	—	—	V	$I_{\text{OH}} \geq -1.4 \text{ mA}$ ; pin out driver= medium
		$V_{\text{DDP}} - 0.4$	—	—	V	$I_{\text{OH}} \geq -1.4 \text{ mA}$ ; pin out driver= strong
		2.4	—	—	V	$I_{\text{OH}} \geq -2 \text{ mA}$ ; pin out driver= medium
		2.4	—	—	V	$I_{\text{OH}} \geq -2 \text{ mA}$ ; pin out driver= strong
		$V_{\text{DDP}} - 0.4$	—	—	V	$I_{\text{OH}} \geq -400 \mu\text{A}$ ; pin out driver= weak
		2.4	—	—	V	$I_{\text{OH}} \geq -500 \mu\text{A}$ ; pin out driver= weak
Output voltage low class A1+ pads	$V_{\text{OLA1+CC}}$	—	—	0.4	V	$I_{\text{OL}} \leq 2 \text{ mA}$ ; pin out driver= medium
		—	—	0.4	V	$I_{\text{OL}} \leq 2 \text{ mA}$ ; pin out driver= strong
		—	—	0.4	V	$I_{\text{OL}} \leq 500 \mu\text{A}$ ; pin out driver= weak

1) Hysteresis is implemented to avoid metastable states and switching due to internal ground bounce. It can't be guaranteed that it suppresses switching due to external system noise.



## Electrical Parameters DC Parameters

Table 22 Standard\_Pads Class\_A2

Parameter	Symbol	Values			Unit	Note / Test Condition
		Min.	Typ.	Max.		
Input Hysteresis for A2 pads <sup>1)</sup>	$H_{YSA2}$ CC	$0.1 \times V_{DDP}$	–	–	V	
Input Leakage current Class A2	$I_{OZA2}$ CC	-6000	–	6000	nA	$V_i < V_{DDP} / 2 - 1 \text{ V}; V_i > V_{DDP} / 2 + 1 \text{ V}; V_i \geq 0 \text{ V}; V_i \leq V_{DDP} \text{ V}$
		-3000	–	3000	nA	$V_i > V_{DDP} / 2 - 1 \text{ V}; V_i < V_{DDP} / 2 + 1 \text{ V}$
Ratio $V_{il}/V_{ih}$ , A2 pads	$V_{ILA2} / V_{IHA2}$ CC	0.6	–	–		
On-Resistance of the class A2 pad, weak driver	$R_{DSONW}$ CC	–	450	600	Ohm	$I_{OH} > -0.5 \text{ mA}; P\_MOS$
		–	210	340	Ohm	$I_{OL} < 0.5 \text{ mA}; N\_MOS$
On-Resistance of the class A2 pad, medium driver	$R_{DSONM}$ CC	–	–	155	Ohm	$I_{OH} > -2 \text{ mA}; P\_MOS$
		–	–	110	Ohm	$I_{OL} < 2 \text{ mA}; N\_MOS$
On-Resistance of the class A2 pad, strong driver	$R_{DSON2}$ CC	–	–	28	Ohm	$I_{OH} > -2 \text{ mA}; P\_MOS$
		–	–	22	Ohm	$I_{OL} < 2 \text{ mA}; N\_MOS$

## Electrical Parameters DC Parameters

Table 22 Standard\_Pads Class\_A2 (cont'd)

Parameter	Symbol	Values			Unit	Note / Test Condition
		Min.	Typ.	Max.		
Fall time, pad type A2	$t_{FA2\ CC}$	–	–	150	ns	$C_L = 20\ \text{pF}$ ; pin out driver= weak
		–	–	7	ns	$C_L = 50\ \text{pF}$ ; edge= medium ; pin out driver= strong
		–	–	10	ns	$C_L = 50\ \text{pF}$ ; edge= medium-minus ; pin out driver= strong
		–	–	3.7	ns	$C_L = 50\ \text{pF}$ ; edge= sharp ; pin out driver= strong
		–	–	5	ns	$C_L = 50\ \text{pF}$ ; edge= sharp-minus ; pin out driver= strong
		–	–	16	ns	$C_L = 50\ \text{pF}$ ; edge= soft ; pin out driver= strong
		–	–	50	ns	$C_L = 50\ \text{pF}$ ; pin out driver= medium
		–	–	7.5	ns	$C_L = 100\ \text{pF}$ ; edge= sharp ; pin out driver= strong
		–	–	140	ns	$C_L = 150\ \text{pF}$ ; pin out driver= medium

## Electrical Parameters DC Parameters

Table 22 Standard\_Pads Class\_A2 (cont'd)

Parameter	Symbol	Values			Unit	Note / Test Condition
		Min.	Typ.	Max.		
		–	–	550	ns	$C_L = 150$ pF; pin out driver= weak
		–	–	18000	ns	$C_L = 20000$ pF; pin out driver= medium
		–	–	65000	ns	$C_L = 20000$ pF; pin out driver= weak

## Electrical Parameters DC Parameters

Table 22 Standard\_Pads Class\_A2 (cont'd)

Parameter	Symbol	Values			Unit	Note / Test Condition
		Min.	Typ.	Max.		
Rise time, pad type A2	$t_{RA2\ CC}$	–	–	150	ns	$C_L = 20\ \text{pF}$ ; pin out driver= weak
		–	–	7.0	ns	$C_L = 50\ \text{pF}$ ; edge= medium ; pin out driver= strong
		–	–	10	ns	$C_L = 50\ \text{pF}$ ; edge= medium-minus ; pin out driver= strong
		–	–	3.7	ns	$C_L = 50\ \text{pF}$ ; edge= sharp ; pin out driver= strong
		–	–	5	ns	$C_L = 50\ \text{pF}$ ; edge= sharp-minus ; pin out driver= strong
		–	–	16	ns	$C_L = 50\ \text{pF}$ ; edge= soft ; pin out driver= strong
		–	–	50	ns	$C_L = 50\ \text{pF}$ ; pin out driver= medium
		–	–	7.5	ns	$C_L = 100\ \text{pF}$ ; edge= sharp ; pin out driver= strong
		–	–	140	ns	$C_L = 150\ \text{pF}$ ; pin out driver= medium

## Electrical Parameters DC Parameters

Table 22 Standard\_Pads Class\_A2 (cont'd)

Parameter	Symbol	Values			Unit	Note / Test Condition
		Min.	Typ.	Max.		
		–	–	550	ns	$C_L = 150$ pF; pin out driver= weak
		–	–	18000	ns	$C_L = 20000$ pF; pin out driver= medium
		–	–	65000	ns	$C_L = 20000$ pF; pin out driver= weak
Input high voltage, class A2 pads	$V_{IHA2}$ SR	$0.6 \times V_{DDP}$	–	$\min(V_{DDP} + 0.3, 3.6)$	V	
Input low voltage Class A2 pads	$V_{ILA2}$ SR	-0.3	–	$0.36 \times V_{DDP}$	V	
Output voltage high class A2 pads	$V_{OHA2}$ CC	$V_{DDP} - 0.4$	–	–	V	$I_{OH} \geq -1.4$ mA; pin out driver= medium
		$V_{DDP} - 0.4$	–	–	V	$I_{OH} \geq -1.4$ mA; pin out driver= strong
		2.4	–	–	V	$I_{OH} \geq -2$ mA; pin out driver= medium
		2.4	–	–	V	$I_{OH} \geq -2$ mA; pin out driver= strong
		$V_{DDP} - 0.4$	–	–	V	$I_{OH} \geq -400$ $\mu$ A; pin out driver= weak
		2.4	–	–	V	$I_{OH} \geq -500$ $\mu$ A; pin out driver= weak

## Electrical Parameters DC Parameters

Table 22 Standard\_Pads Class\_A2 (cont'd)

Parameter	Symbol	Values			Unit	Note / Test Condition
		Min.	Typ.	Max.		
Output voltage low class A2 pads	$V_{OLA2}$ CC	–	–	0.4	V	$I_{OL} \leq 2$ mA; pin out driver= medium
		–	–	0.4	V	$I_{OL} \leq 2$ mA; pin out driver= strong
		–	–	0.4	V	$I_{OL} \leq 500$ $\mu$ A; pin out driver= weak

1) Hysteresis is implemented to avoid metastable states and switching due to internal ground bounce. It can't be guaranteed that it suppresses switching due to external system noise.

Table 23 Standard\_Pads Class\_F

Parameter	Symbol	Values			Unit	Note / Test Condition
		Min.	Typ.	Max.		
Input Hysteresis F <sup>1)</sup>	$HYSF$ CC	0.05 x $V_{DDP}$	–	–	V	
Input Leakage Current Class F	$I_{OZF}$ CC	-6000	–	6000	nA	$V_i < V_{DDP} / 2 - 1$ V; $V_i > V_{DDP} / 2 + 1$ V; $V_i \geq 0$ V; $V_i \leq V_{DDP}$ V
		-3000	–	3000	nA	$V_i > V_{DDP} / 2 - 1$ V; $V_i < V_{DDP} / 2 + 1$ V
Ratio $V_{il}$ / $V_{ih}$ , F pads	$V_{ILF} / V_{IHF}$ CC	0.6	–	–		
On-Resistance of the class F pad, medium driver	$R_{DSONM}$ CC	–	–	170	Ohm	$I_{OH} > -2$ mA; P_MOS
		–	–	145	Ohm	$I_{OL} < 2$ mA; N_MOS
Fall time, pad type F, CMOS mode	$t_{FF}$ CC	–	–	60	ns	$C_L = 50$ pF
Rise time, pad type F, CMOS mode	$t_{RF}$ CC	–	–	60	ns	$C_L = 50$ pF

## Electrical Parameters DC Parameters

**Table 23 Standard\_Pads Class\_F (cont'd)**

Parameter	Symbol	Values			Unit	Note / Test Condition
		Min.	Typ.	Max.		
Input high voltage, pad class F, CMOS mode	$V_{IHF}$ SR	$0.6 \times V_{DDP}$	–	$\min(V_{DDP} + 0.3, 3.6)$	V	
Input low voltage, Class F pads, CMOS mode	$V_{ILF}$ SR	-0.3	–	$0.36 \times V_{DDP}$	V	
Output high voltage, class F pads, CMOS mode	$V_{OHF}$ CC	$V_{DDP} - 0.4$	–	–	V	$I_{OH} \geq -1.4$ mA
		2.4	–	–	V	$I_{OH} \geq -2$ mA
Output low voltage, class F pads, CMOS mode	$V_{OLF}$ CC	–	–	0.4	V	$I_{OL} \leq 2$ mA

1) Hysteresis is implemented to avoid metastable states and switching due to internal ground bounce. It can't be guaranteed that it suppresses switching due to external system noise.

**Table 24 Standard\_Pads Class\_I**

Parameter	Symbol	Values			Unit	Note / Test Condition
		Min.	Typ.	Max.		
Input Hysteresis Class I <sup>1)</sup>	$HYSI$ CC	$0.1 \times V_{DDP}$	–	–	V	
Input Leakage Current	$I_{OZI}$ CC	-1000	–	1000	nA	
Ratio between low and high input threshold	$V_{ILI} / V_{IHI}$ CC	0.6	–	–		
Input high voltage, class I pins	$V_{IHI}$ SR	$0.6 \times V_{DDP}$	–	$\min(V_{DDP} + 0.3, 3.6)$	V	
Input low voltage, Class I pads	$V_{ILI}$ SR	-0.3	–	$0.36 \times V_{DDP}$	V	

1) Hysteresis is implemented to avoid metastable states and switching due to internal ground bounce. It can't be guaranteed that it suppresses switching due to external system noise.

Class S pad parameters are only valid for  $V_{DDM} = 4.75$  V to 5.25 V.

## Electrical Parameters DC Parameters

**Table 25 Standard\_Pads Class\_S**

Parameter	Symbol	Values			Unit	Note / Test Condition
		Min.	Typ.	Max.		
Input Hysteresis for class S pads <sup>1)</sup>	$H_{YSS}$ CC	0.3	–	–	V	
Input leakage current	$I_{OZS}$ CC	-300	–	300	nA	
Input voltage high	$V_{IHS}$ CC	–	–	3.6	V	
Input voltage low	$V_{ILS}$ CC	1.9	–	–	V	
$V_{ILS}$ Delta <sup>2)</sup>	$V_{ILSD}$ CC	-50	–	50	mV	Maximum input low state threshold variation over 1ms ( $V_{DDP} = \text{constant}$ )

- 1) Hysteresis is implemented to avoid metastable states and switching due to internal ground bounce. It can't be guaranteed that it suppresses switching due to external system noise.
- 2)  $V_{ILSD}$  is implemented to ensure J2716 specification. It can't be guaranteed that it suppresses switching due to external noise.

**Table 26 LVDS\_Pads Parameters**

Parameter	Symbol	Values			Unit	Note / Test Condition
		Min.	Typ.	Max.		
Output impedance, pad class F, LVDS mode	$R_O$ CC	40	–	140	Ohm	
Fall time, pad type LVDS	$t_{FL}$ CC	–	–	2	ns	termination 100 $\Omega \pm 1\%$ ; differential capacitance = 10 pF; input capacitance = 20 pF



## Electrical Parameters DC Parameters

**Table 26 LVDS\_Pads Parameters (cont'd)**

Parameter	Symbol	Values			Unit	Note / Test Condition
		Min.	Typ.	Max.		
Rise time, pad type LVDS	$t_{RL\ CC}$	–	–	2	ns	termination 100 $\Omega$ $\pm$ 1 %; differential capacitance = 1 0 pF; input capacitance = 2 0 pF
Pad set-up time	$t_{SET\_LVD\ S\ CC}$	–	–	13	$\mu$ s	termination 100 $\Omega$ $\pm$ 1 %
Output Differential Voltage	$V_{OD\ CC}$	150	–	400	mV	termination 100 $\Omega$ $\pm$ 1 %
Output voltage high, pad class F, LVDS mode	$V_{OH\ CC}$	–	–	1525	mV	termination 100 $\Omega$ $\pm$ 1 %
Output voltage low, pad class F, LVDS mode	$V_{OL\ CC}$	875	–	–	mV	termination 100 $\Omega$ $\pm$ 1 %
Output Offset Voltage	$V_{OS\ CC}$	1075	–	1325	mV	termination 100 $\Omega$ $\pm$ 1 %

## Electrical Parameters DC Parameters

## 5.2.2 Analog to Digital Converters (ADCx)

ADC parameter are valid for  $V_{DD} / V_{DDAF} = 1.235 \text{ V to } 1.365 \text{ V}$ ;  $V_{DDM} = 4.5 \text{ V to } 5.5 \text{ V}$ .

Table 27 ADC Parameters

Parameter	Symbol	Values			Unit	Note / Test Condition
		Min.	Typ.	Max.		
Switched capacitance at the analog voltage inputs <sup>1)</sup>	$C_{AINSW}$ CC	–	9	20	pF	
Total capacitance of an analog input	$C_{AINTOT}$ CC	–	20	30	pF	
Switched capacitance at the positive reference voltage input <sup>2)(3)</sup>	$C_{AREFSW}$ CC	–	15	30	pF	
Total capacitance of the voltage reference inputs <sup>2)</sup>	$C_{AREFTO}$ T CC	–	20	40	pF	
Differential Non-Linearity Error <sup>4)(5)(6)(7)</sup>	$EA_{DNL}$ CC	-3	–	3	LSB	ADC resolution= 12-bit <sup>8) 9)</sup>
Gain Error <sup>4)(5)(6)(7)</sup>	$EA_{GAIN}$ CC	-3.5	–	3.5	LSB	ADC resolution= 12-bit <sup>8) 9)</sup>
Integral Non-Linearity <sup>4)(5)(6)(7)</sup>	$EA_{INL}$ CC	-3	–	3	LSB	ADC resolution= 12-bit <sup>8) 9)</sup>
Offset Error <sup>4)(5)(6)(7)</sup>	$EA_{OFF}$ CC	-4	–	4	LSB	ADC resolution= 12-bit <sup>8) 9)</sup>
Converter clock	$f_{ADC}$ SR	4	–	100	MHz	$f_{ADC} = f_{FPI}$
Internal ADC clock	$f_{ADCI}$ CC	1	–	18	MHz	ADC0
		1	–	18	MHz	ADC1
		1	–	20 <sup>10)</sup>	MHz	ADC2
Charge consumption per conversion	$Q_{CONV}$ CC	70	85 <sup>11)</sup>	100	pC	charge needs to be provided via $V_{AREF0}$

## Electrical Parameters DC Parameters

Table 27 ADC Parameters (cont'd)

Parameter	Symbol	Values			Unit	Note / Test Condition
		Min.	Typ.	Max.		
Input leakage at analog inputs <sup>12)</sup>	$I_{OZ1}$ CC	-100	–	500	nA	$V_i \leq V_{DDM}$ V; $V_i \geq 0.97 \times V_{DDM}$ V; overlaid= No
		-100	–	600	nA	$V_i \geq 0.97 \times V_{DDM}$ V; $V_i \leq V_{DDM}$ V; overlaid= Yes
		-500	–	100	nA	$V_i \leq 0.03 \times V_{DDM}$ V; $V_i \geq 0$ V; overlaid= No
		-600	–	100	nA	$V_i \leq 0.03 \times V_{DDM}$ V; $V_i \geq 0$ V; overlaid= Yes
		-100	–	200	nA	$V_i > 0.03 \times V_{DDM}$ V; $V_i < 0.97 \times V_{DDM}$ V; overlaid= No
		-100	–	300	nA	$V_i < 0.97 \times V_{DDM}$ V; $V_i > 0.03 \times V_{DDM}$ V; overlaid= Yes
		Input leakage current at $V_{AREF0} / V_{AREF2}$	$I_{OZ2}$ CC	-1	–	1
Input leakage current at $V_{AREF1}$	-2	–		2	$\mu$ A	$V_{AREFx} \geq 0$ V; $V_{AREFx} \leq V_{DDM}$ V
Input leakage current at $V_{AGND0}$	$I_{OZ3}$ CC	-4	–	4	$\mu$ A	$V_{AGND0} \geq 0$ V; $V_{AGND0} \leq V_{DDM}$ V
ON resistance of the transmission gates in the analog voltage path	$R_{AIN}$ CC	–	900	1500	Ohm	

## Electrical Parameters DC Parameters

Table 27 ADC Parameters (cont'd)

Parameter	Symbol	Values			Unit	Note / Test Condition
		Min.	Typ.	Max.		
ON resistance for the ADC test (pull down for AIN7)	$R_{AIN7T}$ CC	180	550	900	Ohm	
Resistance of the reference voltage input path	$R_{AREF}$ CC	–	500	1000	Ohm	
Sample time	$t_S$ CC	2	–	257	$T_{ADCI}$	
Calibration time after bit ADC_GLOB_CFG.SUCAL is set	$t_{CAL}$ CC	–	–	4352	cycle s	
Total Unadjusted Error <sup>6)5)13)</sup>	TUE CC	-4	–	4 <sup>14)</sup>	LSB	ADC resolution= 12-bit
Analog reference ground <sup>2)</sup>	$V_{AGNDx}$ SR	$V_{SSM} - 0.05$	–	$V_{AREFx} - 1$	V	
Analog input voltage	$V_{AIN}$ SR	$V_{AGNDx}$	–	$V_{AREFx}$	V	
Analog reference voltage <sup>2)</sup>	$V_{AREFx}$ SR	$V_{AGNDx} + 1$	–	$V_{DDM} + 0.05$ <sup>15)</sup> <sup>16)</sup>	V	
Analog reference voltage range <sup>6)5)2)</sup>	$V_{AREFx} - V_{AGNDx}$ SR	$V_{DDM}/2$	–	$V_{DDM} + 0.05$	V	

- 1) The sampling capacity of the conversion C-network is pre-charged to  $V_{AREF}/2$  before the sampling moment. Because of the parasitic elements the voltage measured at AINx can deviate from  $V_{AREF}/2$ .
- 2) Applies to AINx, when used as auxiliary reference input.
- 3) This represents an equivalent switched capacitance. This capacitance is not switched to the reference voltage at once. Instead smaller capacitances are successively switched to the reference voltage.
- 4) The sum of DNL/INL/GAIN/OFF errors does not exceed the related TUE total unadjusted error.
- 5) If a reduced analog reference voltage between 1V and  $V_{DDM}/2$  is used, then there are additional decrease in the ADC speed and accuracy.
- 6) If the analog reference voltage range is below  $V_{DDM}$  but still in the defined range of  $V_{DDM}/2$  and  $V_{DDM}$  is used, then the ADC converter errors increase. If the reference voltage is reduced by the factor k ( $k < 1$ ), TUE, DNL, INL, Gain, and Offset errors increase also by the factor  $1/k$ .
- 7) If the analog reference voltage is  $> V_{DDM}$ , then the ADC converter errors increase.
- 8) For 10-bit conversions the error value must be multiplied with a factor 0.25.
- 9) For 8-bit conversions the error value must be multiplied with a factor 0.0625.
- 10) For  $f_{ADCI}$  between 18MHz and 20MHz the TUE and Gain Error can increase beyond the given limits. For  $STC < 2$  INL, DNL, and Offset errors can also increase.

**Electrical Parameters DC Parameters**

- 11) For a conversion time of 1  $\mu$ s a rms value of 85 $\mu$ A result for  $I_{AREF0}$ .
- 12) The leakage current definition is a continuous function, as shown in figure ADCx Analogue Input Leakage. The numerical values defined determine the characteristic points of the given continuous linear approximation - they do not define step function.
- 13) Measured without noise.
- 14) For 10-bit conversion the TUE is  $\pm 2$ LSB; for 8-bit conversion the TUE is  $\pm 1$ LSB
- 15) A running conversion may become inexact in case of violating the normal conditions (voltage overshoot).
- 16) If the reference voltage  $V_{AREF}$  increase or the  $V_{DDM}$  decrease, so that  $V_{AREF} = (V_{DDM} + 0.05V \text{ to } V_{DDM} + 0.07V)$ , then the accuracy of the ADC decrease by 4LSB<sup>12</sup>.

**Table 28 Conversion Time** (Operating Conditions apply)

Parameter	Symbol	Values	Unit	Note
Conversion time with post-calibration	$t_C$ CC	$2 \times T_{ADC} + (4 + STC + n) \times T_{ADCI}$	$\mu$ s	n = 8, 10, 12 for n - bit conversion $T_{ADC} = 1 / f_{FPI}$ $T_{ADCI} = 1 / f_{ADCI}$
Conversion time without post-calibration		$2 \times T_{ADC} + (2 + STC + n) \times T_{ADCI}$		

The power-up calibration of the ADC requires a maximum number of 4352  $f_{ADCI}$  cycles.

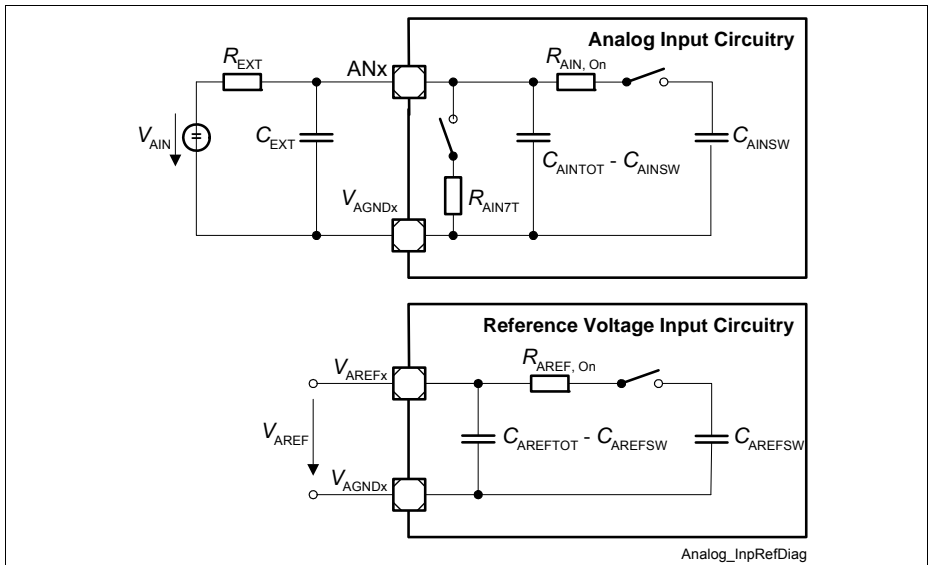

**Figure 8 ADCx Input Circuits**

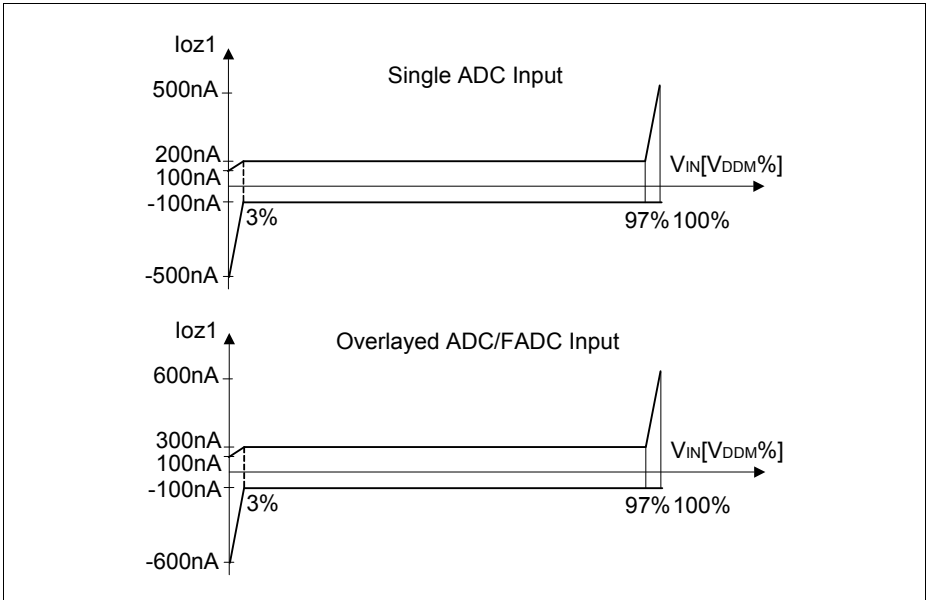

**Figure 9 ADCx Analog Inputs Leakage**

## Electrical Parameters DC Parameters

## 5.2.3 Fast Analog to Digital Converter (FADC)

FADC parameter are valid for  $V_{DD/DDAF} = 1.235\text{ V to }1.365\text{ V}$ ;  $V_{DDMF} = 2.97\text{ V to }3.6\text{ V}$ .

Table 29 FADC Parameters

Parameter	Symbol	Values			Unit	Note / Test Condition
		Min.	Typ.	Max.		
Input current at VFAREF	$I_{FAREF}$ CC	–	–	120	μA	
Input leakage current at VFAREF <sup>1)</sup>	$I_{FOZ2}$ CC	-500	–	500	nA	$V_{FAREF} \leq V_{DDMF}$ $V$ ; $V_{FAREF} \geq 0\text{ V}$
Input leakage current at VFAGND	$I_{FOZ3}$ CC	-500	–	500	nA	
DNL error	$EF_{DNL}$ CC	-1	–	1	LSB	$V_{IN}$ mode= differential; Gain = 1 or 2
		-2	–	2	LSB	$V_{IN}$ mode= differential; Gain = 4 or 8 <sup>2)</sup>
		-1	–	1	LSB	$V_{IN}$ mode= single ended; Gain = 1 or 2
		-2	–	2	LSB	$V_{IN}$ mode= single ended; Gain = 4 or 8 <sup>2)</sup>
GRADient error	$EF_{GRAD}$ CC	-5	–	5	%	$V_{IN}$ mode= differential ; Gain ≤ 4
		-5	–	5	%	$V_{IN}$ mode= single ended ; Gain ≤ 4
		-6	–	6	%	$V_{IN}$ mode= differential ; Gain= 8
		-6	–	6	%	$V_{IN}$ mode= single ended ; Gain= 8

## Electrical Parameters DC Parameters

Table 29 FADC Parameters (cont'd)

Parameter	Symbol	Values			Unit	Note / Test Condition
		Min.	Typ.	Max.		
INL error	$EF_{\text{INL}}$ CC	-4	–	4	LSB	$V_{\text{IN}}$ mode= differential
		-4	–	4	LSB	$V_{\text{IN}}$ mode= single ended
Offset error	$EF_{\text{OFF}}$ CC	-90	–	90	mV	$V_{\text{IN}}$ mode= differential ; Calibration= No
		-90	–	90	mV	$V_{\text{IN}}$ mode= single ended ; Calibration= No
		-20	–	20	mV	$V_{\text{IN}}$ mode= differential ; Calibration= Yes <sup>3)4)</sup>
		-20	–	20	mV	$V_{\text{IN}}$ mode= single ended ; Calibration= Yes <sup>3)4)</sup>
Error of common mode voltage $V_{\text{FAREF}}/2$	$EF_{\text{REF}}$ CC	-60	–	60	mV	
Channel amplifier cutoff frequency	$f_{\text{COFF}}$ CC	2	–	–	MHz	
Converter clock	$f_{\text{FADC}}$ SR	1	–	100	MHz	$f_{\text{FADC}} = f_{\text{FPI}}$
Conversion time	$t_{\text{C}}$ CC	–	–	21	1 / $f_{\text{FADC}}$	For 10-bit conversion
Input resistance of the analog voltage path (Rn, Rp)	$R_{\text{FAIN}}$ CC	100	–	200	kOhm	
Settling time of a channel amplifier after changing ENN or ENP	$t_{\text{SET}}$ CC	–	–	5	μs	
Analog input voltage range	$V_{\text{AINF}}$ SR	$V_{\text{FAGND}}$	–	$V_{\text{DDMF}}$	V	



## Electrical Parameters DC Parameters

**Table 29 FADC Parameters (cont'd)**

Parameter	Symbol	Values			Unit	Note / Test Condition
		Min.	Typ.	Max.		
Analog reference ground	$V_{FAGND}$ SR	$V_{SSAF} - 0.05$	–	$V_{SSAF} + 0.05$	V	
Analog reference voltage	$V_{FAREF}$ SR	2.97	–	$3.63^{5)}$ $6)$	V	

- 1) This value applies in power-down mode.
- 2) No missing codes.
- 3) Calibration should be performed at each power-up. In case of a continuous operation, it should be performed minimum once per week.
- 4) The offset error voltage drifts over the whole temperature range maximum  $\pm 3$ LSB.
- 5) Voltage overshoot to 4V is permissible, provided the pulse duration is less than 100  $\mu$ s and the cumulated sum of the pulses does not exceed 1 h.
- 6) A running conversion may become inexact in case of violating the normal operating conditions (voltage overshoots).

The calibration procedure should run after each power-up, when all power supply voltages and the reference voltage have stabilized.

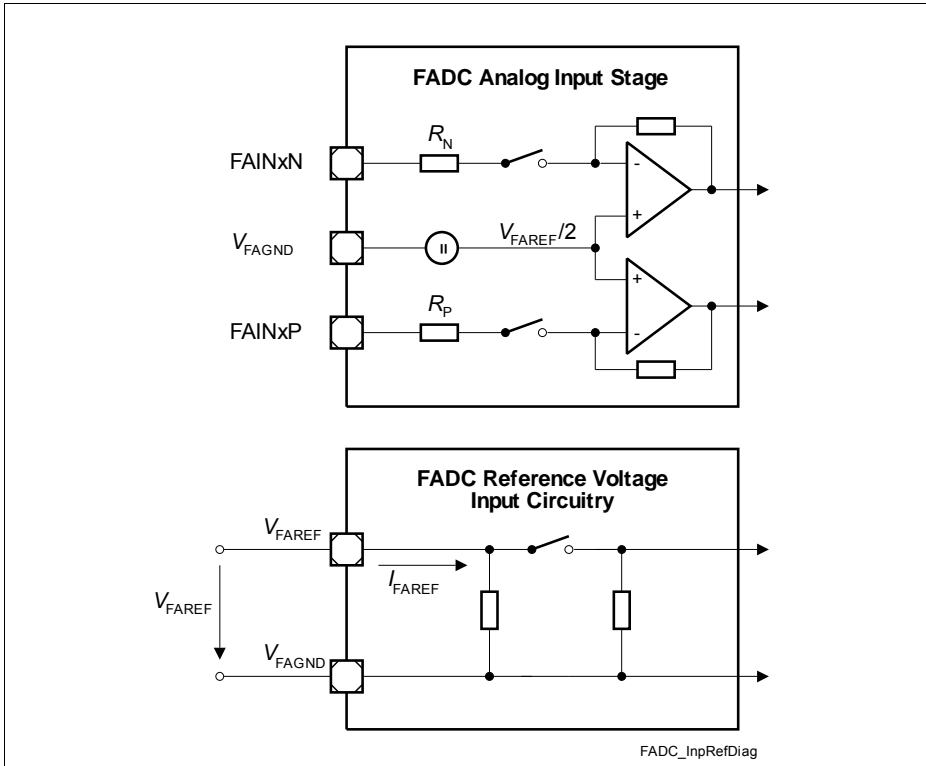

Figure 10 FADC Input Circuits

## 5.2.4 Oscillator Pins

Table 30 OSC\_XTAL Parameters

Parameter	Symbol	Values			Unit	Note / Test Condition
		Min.	Typ.	Max.		
Input current at XTAL1	$I_{IX1}$ CC	-25	–	25	$\mu\text{A}$	$V_{IN} < V_{DDOSC3}$ ; $V_{IN} > 0$ V
Input frequency	$f_{OSC}$ SR	4	–	40	MHz	Direct Input Mode selected
		8	–	25	MHz	External Crystal Mode selected
Oscillator start-up time <sup>1)</sup>	$t_{OSCS}$ CC	–	–	10	ms	
Input high voltage at XTAL1 <sup>2)</sup>	$V_{IHx}$ SR	$0.7 \times V_{DDOS C3}$	–	$V_{DDOS C3} + 0.5$	V	
Input low voltage at XTAL1	$V_{ILx}$ SR	-0.5	–	$0.3 \times V_{DDOS C3}$	V	
Input Hysteresis for XTAL1 pad <sup>3)</sup>	$HYSAX$ CC	–	–	200	mV	

1)  $t_{OSCS}$  is defined from the moment when  $V_{DDOSC3} = 3.13\text{V}$  until the oscillations reach an amplitude at XTAL1 of  $0.3 \times V_{DDOSC3}$ . The external oscillator circuitry must be optimized by the customer and checked for negative resistance as recommended and specified by crystal suppliers.

2) If the XTAL1 pin is driven by a crystal, reaching a minimum amplitude (peak-to-peak) of  $0.4 \times V_{DDOSC3}$  is necessary.

3) Hysteresis is implemented to avoid metastable states and switching due to internal ground bounce. It can't be guaranteed that it suppresses switching due to external system noise.

*Note: It is strongly recommended to measure the oscillation allowance (negative resistance) in the final target system (layout) to determine the optimal parameters for the oscillator operation. Please refer to the limits specified by the crystal or ceramic resonator supplier.*

### 5.2.5 Temperature Sensor

**Table 31 DTS Parameters**

Parameter	Symbol	Values			Unit	Note / Test Condition
		Min.	Typ.	Max.		
Measurement time	$t_M$ CC	–	–	100	μs	
Temperature sensor range	$T_{SR}$ SR	-40	–	150	°C	
Sensor Accuracy (calibrated)	$T_{TSA}$ CC	-6	–	6	°C	
Start-up time after resets inactive	$t_{TSST}$ SR	–	–	20	μs	

The following formula calculates the temperature measured by the DTS in [°C] from the RESULT bit field of the DTSSTAT register.

(1)

$$T_j = \frac{DTSSTAT_{RESULT} - 596}{2,03}$$

### 5.2.6 Power Supply Current

The total power supply current defined below consists of leakage and switching component.

Application relevant values are typically lower than those given in the following two tables and depend on the customer's system operating conditions (e.g. thermal connection or used application configurations).

The operating conditions for the parameters in the following table are:

$V_{DD} / V_{DDOSC} / V_{DDAF} / V_{DDPF} = 1.365 \text{ V}$ ,  $V_{DDP} / V_{DDOSC} / V_{DDMF} / V_{DDFL3} / V_{DDPF} = 3.47 \text{ V}$ ,  
 $V_{DDM} = 5.25 \text{ V}$   $f_{SRI} / CPU = 240 / 200 \text{ MHz}$ ,  $f_{PCP} = 120 / 200 \text{ MHz}$ ,  $f_{SRI} = 80 / 100 \text{ MHz}$ ,  
 $T_J = 150 \text{ }^\circ\text{C}$

The realistic power pattern defines the following conditions:

- $T_J = 150 \text{ }^\circ\text{C}$
- $f_{SRI} = f_{CPU} = 240 / 200 \text{ MHz}$
- $f_{PCP} = 120 / 200 \text{ MHz}$
- $f_{FPI} = 80 / 100 \text{ MHz}$
- $V_{DD} = V_{DDOSC} = V_{DDAF} = V_{DDPF} = 1.326 \text{ V}$
- $V_{DDP} = V_{DDOSC3} = V_{DDFL3} V_{DDPF3} = V_{DDMF} = 3.366 \text{ V}$
- $V_{DDM} = 5.1 \text{ V}$

The max power pattern defines the following conditions:

- $T_J = 150 \text{ }^\circ\text{C}$
- $f_{SRI} = f_{CPU} = 240 / 200 \text{ MHz}$
- $f_{PCP} = 120 / 200 \text{ MHz}$
- $f_{FPI} = 80 / 100 \text{ MHz}$
- $V_{DD} = V_{DDOSC} = V_{DDAF} = V_{DDPF} = 1.43 \text{ V}$
- $V_{DDP} = V_{DDOSC3} = V_{DDFL3} V_{DDPF3} = V_{DDMF} = 3.63 \text{ V}$
- $V_{DDM} = 5.5 \text{ V}$

## Electrical Parameters DC Parameters

Table 32 Power Supply Parameters

Parameter	Symbol	Values			Unit	Note / Test Condition
		Min.	Typ.	Max.		
Core active mode supply current <sup>1)2)</sup>	$I_{DD\ CC}$	–	–	789 <sup>3)</sup>	mA	power pattern= max; $f_{CPU}=240\text{ MHz}$
		–	–	591	mA	power pattern= realistic; $f_{CPU}=240\text{ MHz}$
		–	–	735 <sup>4)</sup>	mA	power pattern= max; $f_{CPU}=200\text{ MHz}$
		–	–	555	mA	power pattern= realistic; $f_{CPU}=200\text{ MHz}$
$I_{DD}$ current at PORST Low	$I_{DD\_PORS\ T\ CC}$	–	–	298	mA	$T_J=150\text{ °C}$
		–	–	249	mA	$T_J=140\text{ °C}$
E-Ray PLL core supply current	$I_{DDPF\ CC}$	–	–	4	mA	
Oscillator core supply current	$I_{DDOSC\ CC}$	–	–	3	mA	
Analog core supply current	$I_{DDAF\ CC}$	–	–	26	mA	
Sum of all 1.3 V supply currents	$I_{DDSUM\ CC}$	–	–	624	mA	power pattern= realistic; $f_{CPU}=240\text{ MHz}$
		–	–	588	mA	power pattern= realistic; $f_{CPU}=200\text{ MHz}$
E-Ray PLL 3.3V supply	$I_{DDPF3\ CC}$	–	–	4	mA	
Oscillator power supply current, 3.3V	$I_{DDOSC3\ CC}$	–	–	11	mA	

## Electrical Parameters DC Parameters

Table 32 Power Supply Parameters (cont'd)

Parameter	Symbol	Values			Unit	Note / Test Condition
		Min.	Typ.	Max.		
FADC analog supply current, 3.3V	$I_{DDMF}$ CC	–	–	15	mA	
$I_{DDP}$ current at PORST Low	$I_{DDP\_PORST}$ CC	–	–	7	mA	
$I_{DDP}$ current no pad activity, LVDS off <sup>5)</sup>	$I_{DDP}$ CC	–	–	$I_{DDP\_PORST} + 25$	mA	including flash read current
		–	–	$I_{DDP\_PORST} + 55$	mA	including flash programming current <sup>6)</sup>
		–	–	$I_{DDP\_PORST} + 40$ <sup>7)</sup>	mA	including flash erase verify current <sup>6)</sup>
Flash memory current <sup>5)</sup>	$I_{DDFL3}$ CC	–	–	98	mA	flash read current
		–	–	29	mA	flash programming current <sup>6)</sup>
		–	–	98	mA	flash erase current <sup>6)</sup>
Current Consumption of LVDS Pad Pairs	$I_{LVDS}$ CC	–	–	24	mA	in total for all LVDS pairs
Sum of all 3.3 V supply currents, no pad activity, LVDS off	$I_{DD3SUM}$ CC	–	–	160 <sup>8)</sup>	mA	including flash read current
ADC 5V power supply current	$I_{DDM}$ CC	–	–	6	mA	

## Electrical Parameters DC Parameters

**Table 32 Power Supply Parameters (cont'd)**

Parameter	Symbol	Values			Unit	Note / Test Condition
		Min.	Typ.	Max.		
Maximum power dissipation	PD CC	–	–	1706	mW	power pattern= max; $f_{\text{CPU}}=240$ MHz
		–	–	1449	mW	power pattern= realisti C; $f_{\text{CPU}}=240$ MHz
		–	–	1523	mW	power pattern= max; $f_{\text{CPU}}=200$ MHz
		–	–	1403	mW	power pattern= realisti C; $f_{\text{CPU}}=200$ MHz

- 1) Infineon Power Loop: CPU and PCP running, all peripherals active. The power consumption of each customer application will most probably be lower than this value, but must be evaluated separately.
- 2) This current includes the E-Ray module power consumption, including the PCP operation component.
- 3) The  $I_{\text{DD}}$  decreases typically by 102 mA if the  $f_{\text{CPU}}$  decreases by 50MHz, at constant  $T_j$
- 4) The  $I_{\text{DD}}$  decreases typically by 105 mA if the  $f_{\text{CPU}}$  decreases by 50MHz, at constant  $T_j$
- 5) For operations including the D-Flash the required currents are always lower than the currents for non D-Flash operation.
- 6) Relevant for the power supply dimensioning, not for thermal considerations.
- 7) In case of erase of Program Flash PFx, internal flash array loading effects may generate transient current spikes of up to 15 mA for maximum 5 ms per flash module.
- 8) For power supply dimensioning of  $V_{\text{DDP}}$  30 mA have to added for flash programming case.

*Note: In general current consumption for operations with data flash are always lower than the defined values for program flash read operation.*

### 5.2.6.1 Calculating the 1.3 V Current Consumption

The current consumption of the 1.3 V rail compose out of two parts:

- Static current consumption
- Dynamic current consumption

The static current consumption is related to the device temperature  $T_j$  and the dynamic current consumption depends of the configured clocking frequencies and the software



---

**Electrical Parameters DC Parameters**

application executed. These two parts needs to be added in order to get the rail current consumption.

(2)

$$I_0 = 3,75 \left[ \frac{\text{mA}}{\text{C}} \right] \times e^{0,02041 \times T_J[\text{C}]}$$

(3)

$$I_0 = 18,77 \left[ \frac{\text{mA}}{\text{C}} \right] \times e^{0,01825 \times T_J[\text{C}]}$$

Function 2 defines the typical static current consumption and Function 3 defines the maximum static current consumption. Both functions are valid for  $V_{DD} = 1.326 \text{ V}$ .

For the dynamic current consumption using the real pattern and  $f_{SRI} = 2 * f_{PCP} = 3 * f_{FPI}$  the function 4 applies:

(4)

$$I_{Dym} = 1,22 \left[ \frac{\text{mA}}{\text{MHz}} \right] \times f_{CPU}[\text{MHz}]$$

For the dynamic current consumption using the real pattern and  $f_{SRI} = f_{PCP} = 2 * f_{FPI}$  the function 5 applies:

(5)

$$I_{Dym} = 1,305 \left[ \frac{\text{mA}}{\text{MHz}} \right] \times f_{CPU}[\text{MHz}]$$

and this finally results in

(6)

$$I_{DD} = I_0 + I_{DYM}$$

### 5.3 AC Parameters

All AC parameters are defined with maximum driver strength unless otherwise noted.

#### 5.3.1 Testing Waveforms

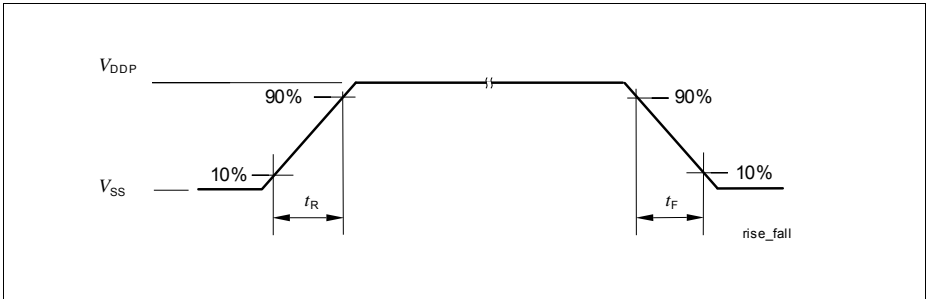

Figure 11 Rise/Fall Time Parameters

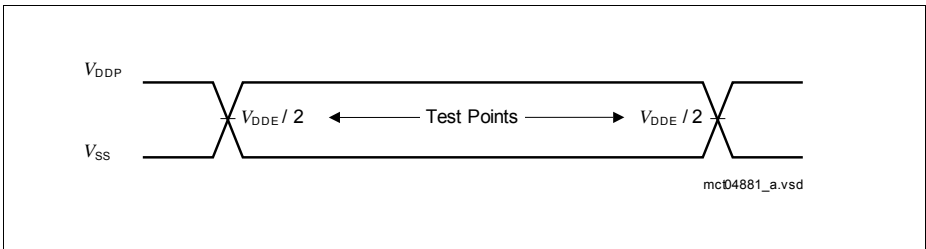

Figure 12 Testing Waveform, Output Delay

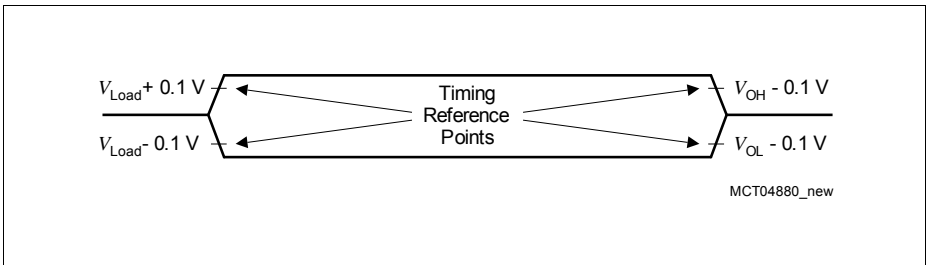
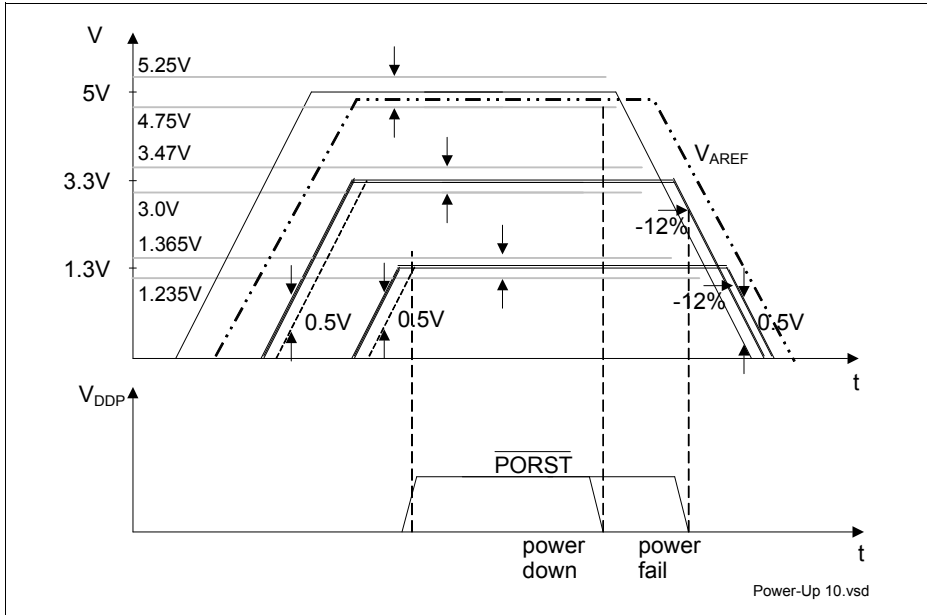

Figure 13 Testing Waveform, Output High Impedance

### 5.3.2 Power Sequencing



**Figure 14 5 V / 3.3 V / 1.3 V Power-Up/Down Sequence**

The following list of rules applies to the power-up/down sequence:

- All ground pins  $V_{SS}$  must be externally connected to one single star point in the system. Regarding the DC current component, all ground pins are internally directly connected.
- At any moment in time to avoid increased latch-up risk, each power supply must be higher than any lower\_power\_supply - 0.5 V, or:  
 $V_{DD5} > V_{DD3.3} - 0.5 \text{ V}$ ;  $V_{DD5} > V_{DD1.3} - 0.5 \text{ V}$ ;  $V_{DD3.3} > V_{DD1.3} - 0.5 \text{ V}$ , see [Figure 14](#).
  - The latch-up risk is minimized if the I/O currents are limited to:
    - 20 mA for one pin group
    - AND 100 mA for the completed device I/Os
    - AND additionally before power-up / after power-down:
      - 1 mA for one pin in inactive mode (0 V on all power supplies)
- During power-up and power-down, the voltage difference between the power supply pins of the same voltage (3.3 V, 1.3 V, and 5 V) with different names (for example  $V_{DDP}$ ,  $V_{DDFL3}$  ...), that are internally connected via diodes, must be lower than 100 mV. On the other hand, all power supply pins with the same name (for example all  $V_{DDP}$ ),

## Electrical Parameters AC Parameters

are internally directly connected. It is recommended that the power pins of the same voltage are driven by a single power supply.

1. The  $\overline{\text{PORST}}$  signal may be deactivated after all  $V_{\text{DD}5}$ ,  $V_{\text{DD}3.3}$ ,  $V_{\text{DD}1.3}$ , and  $V_{\text{AREF}}$  power-supplies and the oscillator have reached stable operation, within the normal operating conditions.
2. At normal power down the  $\overline{\text{PORST}}$  signal should be activated within the normal operating range, and then the power supplies may be switched off. Care must be taken that all Flash write or delete sequences have been completed.
3. At power fail the  $\overline{\text{PORST}}$  signal must be activated at latest when any 3.3 V or 1.3 V power supply voltage falls 12% below the nominal level. If, under these conditions, the  $\overline{\text{PORST}}$  is activated during a Flash write, only the memory row that was the target of the write at the moment of the power loss will contain unreliable content. In order to ensure clean power-down behavior, the  $\overline{\text{PORST}}$  signal should be activated as close as possible to the normal operating voltage range.
4. In case of a power-loss at any power-supply, all power supplies must be powered-down, conforming at the same time to the rules number 2 and 4.
5. Although not necessary, it is additionally recommended that all power supplies are powered-up/down together in a controlled way, as tight to each other as possible.
6. Additionally, regarding the ADC reference voltage  $V_{\text{AREF}}$ :
  - $V_{\text{AREF}}$  must power-up at the same time or later then  $V_{\text{DDM}}$ , and
  - $V_{\text{AREF}}$  must power-down either earlier or at latest to satisfy the condition  $V_{\text{AREF}} < V_{\text{DDM}} + 0.5 \text{ V}$ . This is required in order to prevent discharge of  $V_{\text{AREF}}$  filter capacitance through the ESD diodes through the  $V_{\text{DDM}}$  power supply. In case of discharging the reference capacitance through the ESD diodes, the current must be lower than 5 mA.

### 5.3.3 Power, Pad and Reset Timing

**Table 33 Reset Timings Parameters**

Parameter	Symbol	Values			Unit	Note / Test Condition
		Min.	Typ.	Max.		
Application Reset Boot Time <sup>1)2)</sup>	$t_B$ CC	–	–	1015	$\mu\text{s}$	$f_{\text{CPU}} = 240 \text{ MHz}$
		–	–	1140	$\mu\text{s}$	$f_{\text{CPU}} = 200 \text{ MHz}$
Power on Reset Boot Time <sup>3)4)</sup>	$t_{\text{BP}}$ CC	–	–	2.5	ms	
HWCFG pins hold time from ESR0 rising edge	$t_{\text{HDH}}$ SR	16 / $f_{\text{FPI}}$	–	–	ns	
HWCFG pins setup time to ESR0 rising edge	$t_{\text{HDS}}$ SR	0	–	–	ns	
Ports inactive after ESR0 reset active	$t_{\text{PI}}$ CC	–	–	$8/f_{\text{FPI}}$	ns	
Ports inactive after PORST reset active <sup>5)</sup>	$t_{\text{PIP}}$ CC	–	–	150	ns	
Minimum PORST active time after power supplies are stable at operating levels	$t_{\text{POA}}$ SR	10	–	–	ms	
$\overline{\text{TESTMODE}} / \overline{\text{TRST}}$ hold time from PORST rising edge	$t_{\text{POH}}$ SR	100	–	–	ns	
PORST rise time	$t_{\text{POR}}$ SR	–	–	50	ms	
$\overline{\text{TESTMODE}} / \overline{\text{TRST}}$ setup time to PORST rising edge	$t_{\text{POS}}$ SR	0	–	–	ns	
Application Reset inactive after PORST deassertion	$t_{\text{POR\_APP}}$ SR	–	–	40 <sup>6)</sup>	$\mu\text{s}$	

- 1) The duration of the boot time is defined between the rising edge of the internal application reset and the clock cycle when the first user instruction has entered the CPU pipeline and its processing starts.
- 2) The given time includes the time of the internal reset extension for a configured value of SCU\_RSTCNTCON.RELSA = 0x05BE.
- 3) The duration of the boot time is defined between the rising edge of the  $\overline{\text{PORST}}$  and the clock cycle when the first user instruction has entered the CPU pipeline and its processing starts.
- 4) The given time includes the internal reset extension time for the System and Application Reset which is visible through ESR0.

**Electrical Parameters AC Parameters**

- 5) This parameter includes the delay of the analog spike filter in the  $\overline{\text{PORST}}$  pad.
- 6) Application Reset is assumed not to be extended from external, otherwise the time extends by the time the Application Reset is extended.

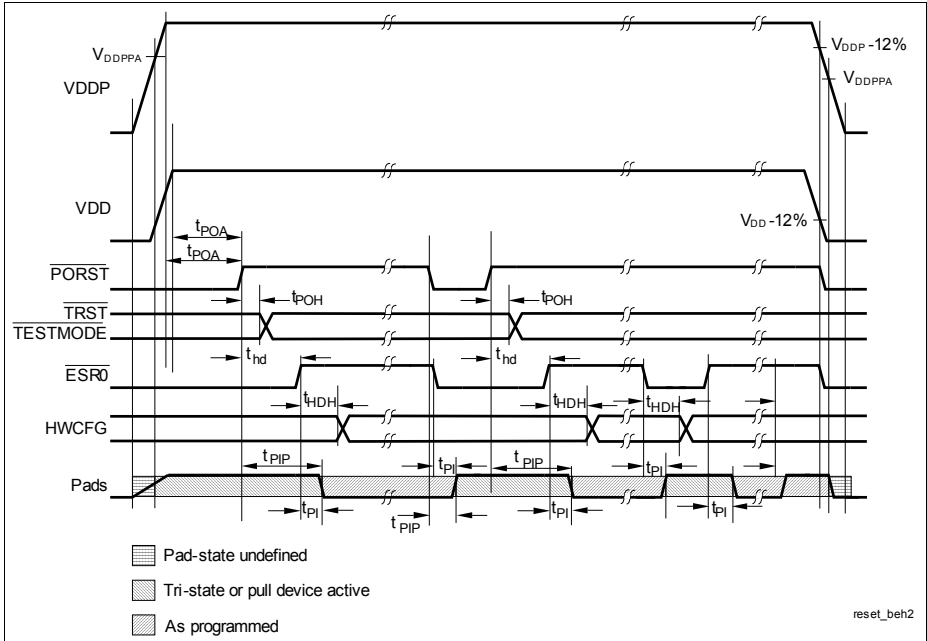

**Figure 15 Power, Pad and Reset Timing**

### 5.3.4 Phase Locked Loop (PLL)

**Table 34 PLL\_SysClk Parameters**

Parameter	Symbol	Values			Unit	Note / Test Condition
		Min.	Typ.	Max.		
Accumulated Jitter	$D_P$ CC	-7	–	7	ns	
Modulation frequency	$f_{MOD}$ SR	50	–	200	kHz	
PLL base frequency	$f_{PLLBASE}$ CC	50	200	320	MHz	
VCO input frequency	$f_{REF}$ CC	8	–	16	MHz	
VCO frequency range	$f_{VCO}$ CC	400	–	720	MHz	with inactive modulation
		400	–	600	MHz	with active modulation
Modulation jitter	$J_{MOD}$ CC	–	–	2.5	ns	
Total long term jitter	$J_{TOT}$ CC	–	–	9.5	ns	Sum of $D_P$ and $J_{MOD}$
Modulation Amplitude	$MA$ SR	0	–	2.5	%	% of $f_{VCO}$
PLL lock-in time	$t_L$ CC	14	–	200	$\mu$ s	$N > 32$
		14	–	400	$\mu$ s	$N \leq 32$
System frequency deviation	$f_{SYSD}$ CC	–	–	0.01	%	with active modulation

#### Phase Locked Loop Operation

When PLL operation is enabled and configured, the PLL clock  $f_{VCO}$  (and with it the SRI-Bus clock  $f_{SRI}$ ) is constantly adjusted to the selected frequency. The PLL is constantly adjusting its output frequency to correspond to the input frequency (from crystal or clock source), resulting in an accumulated jitter that is limited. This means that the relative deviation for periods of more than one clock cycle is lower than for a single clock cycle.

This is especially important for bus cycles using wait states and for the operation of timers, serial interfaces, etc. For all slower operations and longer periods (e.g. pulse train generation or measurement, lower baudrates, etc.) the deviation caused by the PLL jitter is negligible.

**Electrical Parameters AC Parameters**

Two formulas are defined for the (absolute) approximate maximum value of jitter  $D_m$  in [ns] dependent on the K2 - factor, the SRI clock frequency  $f_{SRI}$  in [MHz], and the number  $m$  of consecutive  $f_{SRI}$  clock periods.

for  $(K2 \leq 100)$  and  $(m \leq (f_{SRI}[\text{MHz}])/2)$

$$|D_m[\text{ns}]| = \left( \frac{740}{K2 \times f_{SRI}[\text{MHz}]} + 5 \right) \times \left( \frac{(1 - 0,01 \times K2) \times (m - 1)}{0,5 \times f_{SRI}[\text{MHz}] - 1} + 0,01 \times K2 \right) \quad (7)$$

$$\text{else} \quad |D_m[\text{ns}]| = \frac{740}{K2 \times f_{SRI}[\text{MHz}]} + 5 \quad (8)$$

With rising number  $m$  of clock cycles the maximum jitter increases linearly up to a value of  $m$  that is defined by the K2-factor of the PLL. Beyond this value of  $m$  the maximum accumulated jitter remains at a constant value. Further, a lower SRI-Bus clock frequency  $f_{SRI}$  results in a higher absolute maximum jitter value.

*Note: The specified PLL jitter values are valid if the capacitive load per pin does not exceed  $C_L = 20$  pF with the maximum driver and sharp edge.*

*Note: The maximum peak-to-peak noise on the pad supply voltage, measured between  $V_{DDOSC3}$  and  $V_{SSOSC}$ , is limited to a peak-to-peak voltage of  $V_{PP} = 100$  mV for noise frequencies below 300 KHz and  $V_{PP} = 40$  mV for noise frequencies above 300 KHz.*

*The maximum peak-to-peak noise on the pad supply voltage, measured between  $V_{DDOSC}$  and  $V_{SSOSC}$ , is limited to a peak-to-peak voltage of  $V_{PP} = 100$  mV for noise frequencies below 300 KHz and  $V_{PP} = 40$  mV for noise frequencies above 300 KHz.*

*These conditions can be achieved by appropriate blocking of the supply voltage as near as possible to the supply pins and using PCB supply and ground planes.*

**Oscillator Watchdog (OSC\_WDT)**

The expected input frequency is selected via the bit field SCU\_OSCCON.OSCVAL. The OSC\_WDT checks for too low frequencies and for too high frequencies.

The frequency that is monitored is  $f_{OSCREF}$  which is derived for  $f_{OSC}$ .

(9)

$$f_{OSCREF} = \frac{f_{OSC}}{OSCVAL + 1}$$

The divider value SCU\_OSCCON.OSCVAL has to be selected in a way that  $f_{OSCREF}$  is 2.5 MHz.



---

**Electrical Parameters AC Parameters**

*Note:  $f_{\text{OSCREf}}$  has to be within the range of 2 MHz to 3 MHz and should be as close as possible to 2.5 MHz.*

The monitored frequency is too low if it is below 1.25 MHz and too high if it is above 7.5 MHz. This leads to the following two conditions:

- Too low:  $f_{\text{OSC}} < 1.25 \text{ MHz} \times (\text{SCU\_OSCCON.OSCVAL}+1)$
- Too high:  $f_{\text{OSC}} > 7.5 \text{ MHz} \times (\text{SCU\_OSCCON.OSCVAL}+1)$

*Note: The accuracy is 30% for these boundaries.*

**Frequency Modulation**

Frequency modulation defines a slow and predictable variation of the clock speed. The modulation configuration itself is controlled via register SCU\_PLLCON2 where the two bit fields define the modulation properties.

$$f_{\text{MOD}} = \frac{f_{\text{OSC}}}{P} \times \frac{\text{MODFREQ} \times 31, 32}{\text{MODAMP}} \quad (10)$$

$$\text{MA} = \frac{\text{MODAMP}}{N \times 161} \quad (11)$$

### 5.3.5 ERAY Phase Locked Loop (ERAY\_PLL)

**Table 35 PLL\_ERAY Parameters**

Parameter	Symbol	Values			Unit	Note / Test Condition
		Min.	Typ.	Max.		
Accumulated jitter at SYSCLK pin	$D_{PP}$ CC	-0.8	–	0.8	ns	
Accumulated_Jitter	$D_p$ CC	-0.5	–	0.5	ns	
PLL Base Frequency of the ERAY PLL	$f_{PLLBASE\_ERAY}$ CC	50	250	360	MHz	
VCO input frequency of the ERAY PLL	$f_{REF}$ CC	20	–	40	MHz	
VCO frequency range of the ERAY PLL	$f_{VCO\_ERA}$ CC	450	–	500	MHz	
PLL lock-in time	$t_L$ CC	5.6	–	200	μs	

*Note: The specified PLL jitter values are valid if the capacitive load per pin does not exceed  $C_L = 20$  pF with the maximum driver and sharp edge.*

*Note: The maximum peak-to-peak noise on the pad supply voltage, measured between  $V_{DDPF3}$  and  $V_{SSPF}$ , is limited to a peak-to-peak voltage of  $V_{PP} = 100$  mV for noise frequencies below 300 KHz and  $V_{PP} = 40$  mV for noise frequencies above 300 KHz.*

*These conditions can be achieved by appropriate blocking of the supply voltage as near as possible to the supply pins and using PCB supply and ground planes.*

## Electrical Parameters AC Parameters

**5.3.6 JTAG Interface Timing**

The following parameters are applicable for communication through the JTAG debug interface. The JTAG module is fully compliant with IEEE1149.1-2000.

*Note: These parameters are not subject to production test but verified by design and/or characterization.*

**Table 36 JTAG Interface Timing Parameters  
(Operating Conditions apply)**

Parameter	Symbol	Values			Unit	Note / Test Condition
		Min.	Typ.	Max.		
TCK clock period	$t_1$ SR	25	–	–	ns	–
TCK high time	$t_2$ SR	10	–	–	ns	–
TCK low time	$t_3$ SR	10	–	–	ns	–
TCK clock rise time	$t_4$ SR	–	–	4	ns	–
TCK clock fall time	$t_5$ SR	–	–	4	ns	–
TDI/TMS setup to TCK rising edge	$t_6$ SR	6	–	–	ns	–
TDI/TMS hold after TCK rising edge	$t_7$ SR	6	–	–	ns	–
TDO valid after TCK falling edge <sup>1)</sup> (propagation delay)	$t_8$ CC	–	–	13	ns	$C_L = 50$ pF
	$t_8$ CC	3	–	–	ns	$C_L = 20$ pF
TDO hold after TCK falling edge <sup>1)</sup>	$t_{18}$ CC	2	–	–	ns	
TDO high imped. to valid from TCK falling edge <sup>1)2)</sup>	$t_9$ CC	–	–	14	ns	$C_L = 50$ pF
TDO valid to high imped. from TCK falling edge <sup>1)</sup>	$t_{10}$ CC	–	–	13.5	ns	$C_L = 50$ pF

1) The falling edge on TCK is used to generate the TDO timing.

2) The setup time for TDO is given implicitly by the TCK cycle time.

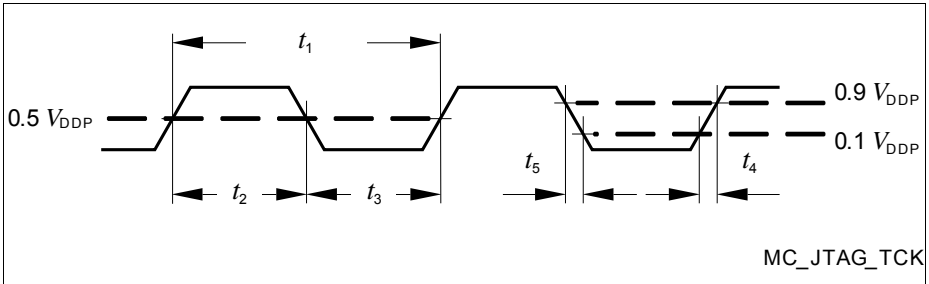

Figure 16 Test Clock Timing (TCK)

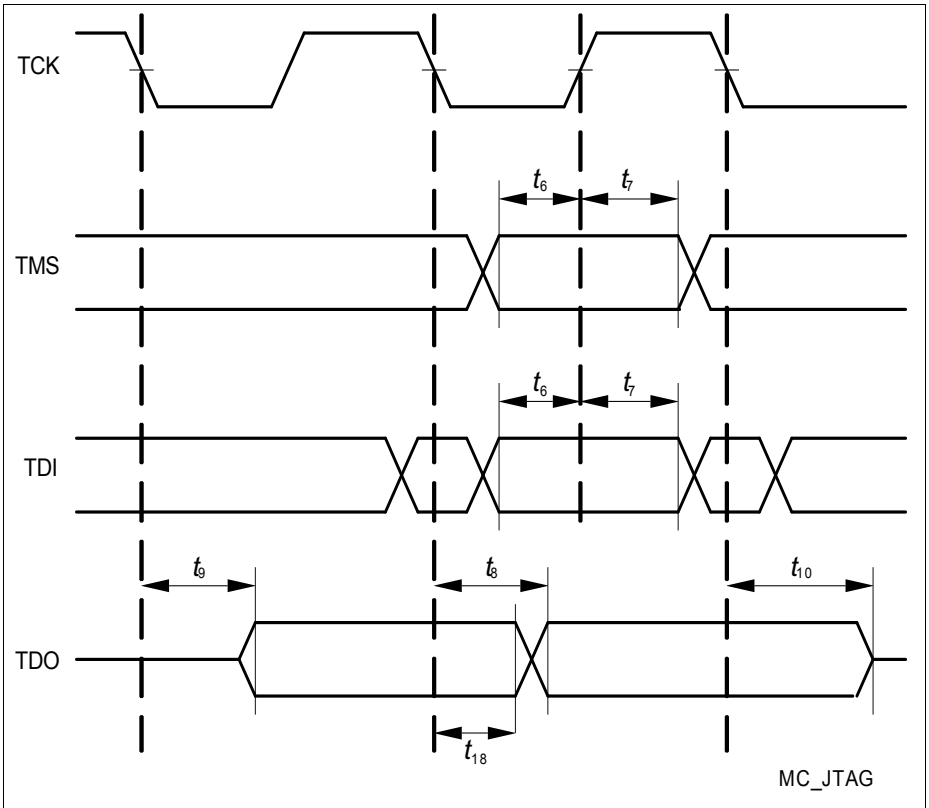

Figure 17 JTAG Timing

### 5.3.7 DAP Interface Timing

The following parameters are applicable for communication through the DAP debug interface.

*Note: These parameters are not subject to production test but verified by design and/or characterization.*

**Table 37 DAP Parameters**

Parameter	Symbol	Values			Unit	Note / Test Condition
		Min.	Typ.	Max.		
DAP0 clock period <sup>1)</sup>	$t_{TCK}$ SR	12.5	–	–	ns	
DAP0 high time	$t_{12}$ SR	4	–	–	ns	
DAP0 low time <sup>1)</sup>	$t_{13}$ SR	4	–	–	ns	
DAP0 clock rise time	$t_{14}$ SR	–	–	2	ns	
DAP0 clock fall time	$t_{15}$ SR	–	–	2	ns	
DAP1 setup to DAP0 rising edge	$t_{16}$ SR	6.0	–	–	ns	
DAP1 hold after DAP0 rising edge	$t_{17}$ SR	6.0	–	–	ns	
DAP1 valid per DAP0 clock period <sup>2)</sup>	$t_{19}$ CC	8	–	–	ns	$C_L = 20$ pF; $f = 80$ MHz
		10	–	–	ns	$C_L = 50$ pF; $f = 40$ MHz

1) See the DAP chapter for clock rate restrictions in the Active:IDLE protocol state.

2) The Host has to find a suitable sampling point by analyzing the sync telegram response.

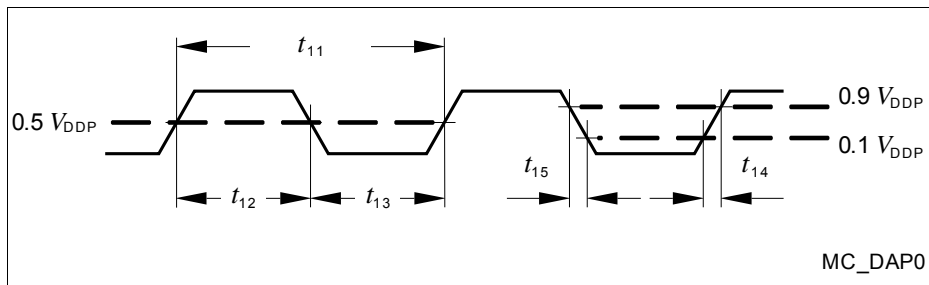

**Figure 18 Test Clock Timing (DAP0)**

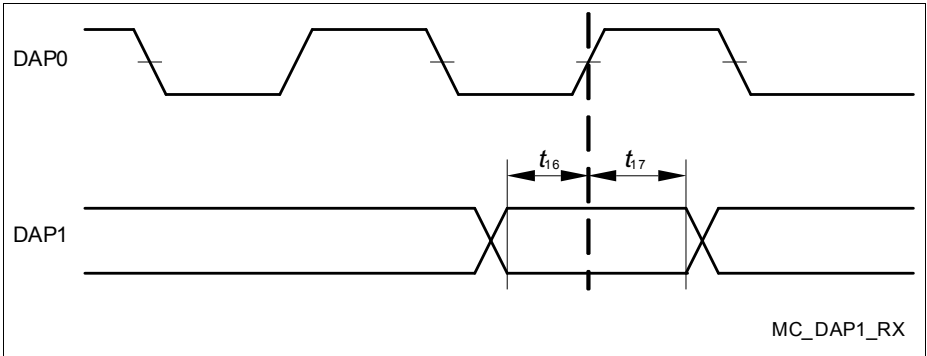

Figure 19 DAP Timing Host to Device

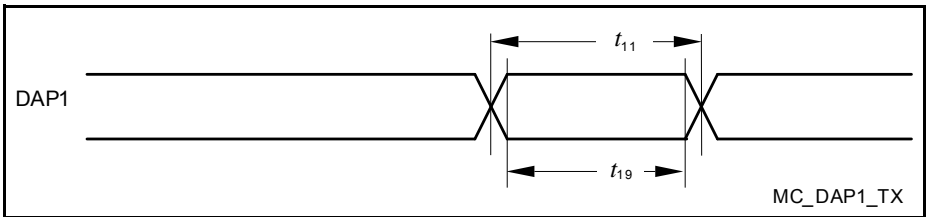
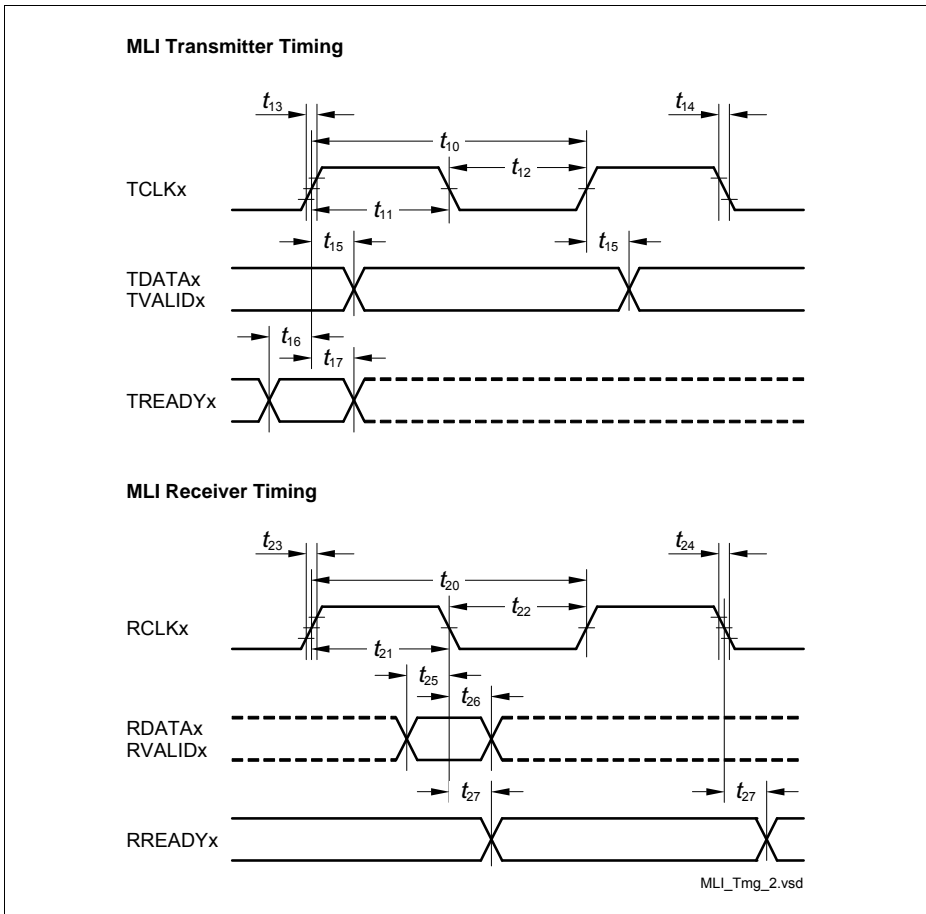

Figure 20 DAP Timing Device to Host

### 5.3.8 Micro Link Interface (MLI) Timing



**Figure 21 MLI Interface Timing**

*Note: The generation of RREADYx is in the input clock domain of the receiver. The reception of TREADYx is asynchronous to TCLKx.*

The MLI parameters are valid for  $C_L = 50$  pF and strong driver medium edge.

## Electrical Parameters AC Parameters

**Table 38 MLI Receiver**

Parameter	Symbol	Values			Unit	Note / Test Condition
		Min.	Typ.	Max.		
RCLK clock period	$t_{20}$ SR	$1 / f_{FPI}$	–	–	ns	
RCLK high time <sup>1)2)</sup>	$t_{21}$ SR	–	$0.5 \times t_{20}$	–	ns	
RCLK low time <sup>1)2)</sup>	$t_{22}$ SR	–	$0.5 \times t_{20}$	–	ns	
RCLK rise time <sup>3)</sup>	$t_{23}$ SR	–	–	4	ns	
RCLK fall time <sup>3)</sup>	$t_{24}$ SR	–	–	4	ns	
RDATA/RVALID setup time before RCLK falling edge	$t_{25}$ SR	4.2	–	–	ns	
RDATA/RVALID hold time after RCLK falling edge	$t_{26}$ SR	2.2	–	–	ns	
RREADY output delay time	$t_{27}$ SR	0	–	16	ns	

1) The following formula is valid:  $t_{21} + t_{22} = t_{20}$ .

2) Min and Max values for this parameter can be derived from the typ. value by considering the other receiver timing parameters.

3) The RCLK max. input rise/fall times are best case parameters for  $f_{SYS} = 90$  MHz. For reduction of EMI, slower input signal rise/fall times can be used for longer RCLK clock periods.

**Table 39 MLI Transmitter**

Parameter	Symbol	Values			Unit	Note / Test Condition
		Min.	Typ.	Max.		
TCLK clock period	$t_{10}$ CC	$2 \times 1 / f_{FPI}$	–	–	ns	
TCLK high time <sup>1)2)</sup>	$t_{11}$ CC	$0.45 \times t_{10}$	$0.5 \times t_{10}$	$0.55 \times t_{10}$	ns	
TCLK low time <sup>1)2)</sup>	$t_{12}$ CC	$0.45 \times t_{10}$	$0.5 \times t_{10}$	$0.55 \times t_{10}$	ns	
TCLK rise time	$t_{13}$ CC	–	–	$0.3 \times t_{10}$ <sup>3)</sup>	ns	
TCLK fall time	$t_{14}$ CC	–	–	$0.3 \times t_{10}$ <sup>3)</sup>	ns	



## Electrical Parameters AC Parameters

**Table 39 MLI Transmitter (cont'd)**

Parameter	Symbol	Values			Unit	Note / Test Condition
		Min.	Typ.	Max.		
TDATA/TVALID output delay time	$t_{15}$ CC	-3	–	4.4	ns	
TREADY setup time before TCLK rising edge	$t_{16}$ SR	18	–	–	ns	
TREADY hold time after TCLK rising edge	$t_{17}$ SR	-2	–	–	ns	

1) The following formula is valid:  $t_{11} + t_{12} = t_{10}$ .

2) The min./max. TCLK low/high times  $t_{11}/t_{12}$  include the PLL jitter of fSYS. Fractional divider settings must be regarded additionally to  $t_{11} / t_{12}$ .

3) For high-speed MLI interface, strong driver sharp or medium edge selection (class A2 pad) is recommended for TCLK.

### 5.3.9 Micro Second Channel (MSC) Interface Timing

The MSC parameters are valid for  $C_L = 50$  pF.

**Table 40 MSC Parameters**

Parameter	Symbol	Values			Unit	Note / Test Condition
		Min.	Typ.	Max.		
FCLP clock period <sup>1)2)</sup>	$t_{40}$ CC	$2 \times T_{MSC}$ <sup>3)</sup>	–	–	ns	
SOP <sup>4)</sup> /ENx outputs delay from FCLP <sup>4)</sup> rising edge	$t_{45}$ CC	-2	–	5	ns	ENx with strong driver and sharp (minus) edge
		-2	–	10	ns	ENx with strong driver and medium (minus) edge
		0	–	21	ns	ENx with strong driver and soft edge
SDI bit time	$t_{46}$ CC	$8 \times T_{MSC}$	–	–	ns	

Electrical Parameters AC Parameters

Table 40 MSC Parameters (cont'd)

Parameter	Symbol	Values			Unit	Note / Test Condition
		Min.	Typ.	Max.		
SDI rise time	$t_{48}$ SR	–	–	200	ns	
SDI fall time	$t_{49}$ SR	–	–	200	ns	

- 1) FCLP signal rise/fall times are only defined by the pad rise/fall times.
- 2) FCLP signal high and low can be minimum  $1 \times T_{MSC}$
- 3)  $T_{MSC} = T_{SYS} = 1 / f_{SYS}$ .
- 4) SOP / FCLP either propagated by LVDS or by CMOS strong driver and non soft edge.

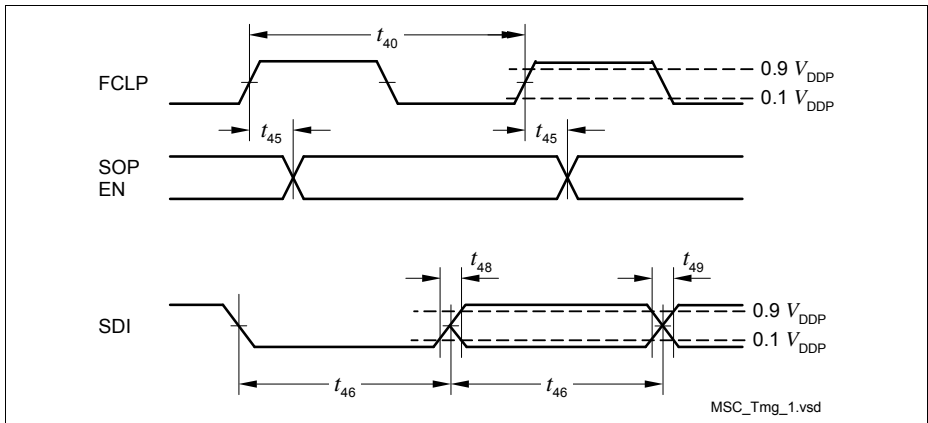

Figure 22 MSC Interface Timing

Note: The data at SOP should be sampled with the falling edge of FCLP in the target device.

### 5.3.10 SSC Master/Slave Mode Timing

The SSC parameters are valid for  $C_L = 50$  pF and strong driver medium edge.

**Table 41 SSC Parameters**

Parameter	Symbol	Values			Unit	Note / Test Condition
		Min.	Typ.	Max.		
SCLK clock period <sup>1)2)3)</sup>	$t_{50}$ CC	$2 \times 1 / f_{FPI}$	–	–	ns	
MTSR/SLSOx delay from SCLK rising edge	$t_{51}$ CC	0	–	8	ns	
MRST setup to SCLK latching edge <sup>3)</sup>	$t_{52}$ SR	16.5	–	–	ns	
MRST hold from SCLK latching edge <sup>3)</sup>	$t_{53}$ SR	0	–	–	ns	
SCLK input clock period <sup>1)3)</sup>	$t_{54}$ SR	$4 \times 1 / f_{FPI}$	–	–	ns	
SCLK input clock duty cycle	$t_{55}$ – $t_{54}$ SR	45	–	55	%	
MTSR setup to SCLK latching edge <sup>3)4)</sup>	$t_{56}$ SR	$1 / f_{FPI}$	–	–	ns	
MTSR hold from SCLK latching edge	$t_{57}$ SR	$1 / f_{FPI} + 5$	–	–	ns	
SLSI setup to first SCLK latching edge	$t_{58}$ SR	$1 / f_{FPI} + 5$	–	–	ns	
SLSI hold from last SCLK latching edge <sup>5)</sup>	$t_{59}$ SR	7	–	–	ns	
MRST delay from SCLK shift edge	$t_{60}$ CC	0	–	16.5	ns	
SLSI to valid data on MRST	$t_{61}$ CC	–	–	16.5	ns	

1) SCLK signal rise/fall times are the same as the rise/fall times of the pad.

2) SCLK signal high and low times can be minimum  $1 \times TSSC$ .

3)  $TSSC_{min} = T_{SYS} = 1/f_{SYS}$ .

4) Fractional divider switched off, SSC internal baud rate generation used.

**Electrical Parameters AC Parameters**

- 5) For CON.PH=1 slave select must not be removed before the following shifting edge. This mean, that what ever is configured (shifting / latching first), SLSI must not be de-activated before the last trailing edge from the pair of shifting / latching edges.

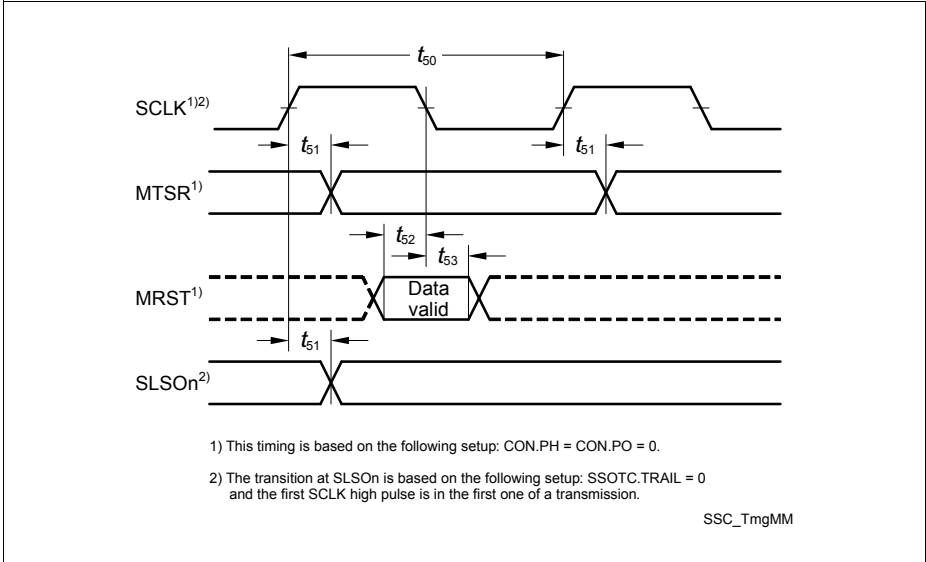

**Figure 23 SSC Master Mode Timing**

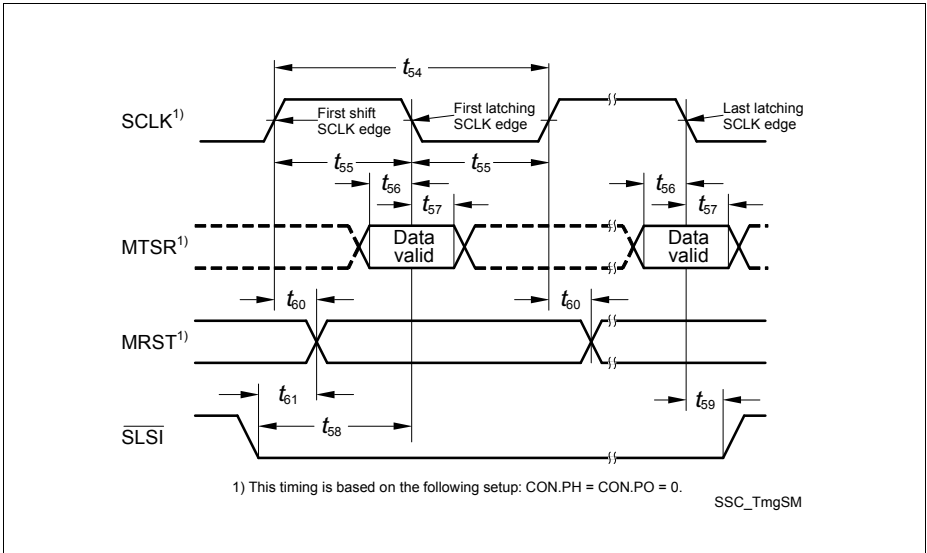

Figure 24 SSC Slave Mode Timing

### 5.3.11 ERAY Interface Timing

The timings of this section are valid for the strong driver and either sharp edge or medium edge settings of the output drivers with  $C_L = 25 \text{ pF}$ .

The ERAY interface is only available for the SAK-TC1791F-512F240EP / SAK-TC1791F-512F240EL / SAK-TC1791S-512F240EP / SAK-TC1791F-384F200EL / SAK-TC1791F-384F200EP / SAK-TC1791S-384F200EP.

**Table 42 ERAY Parameters**

Parameter	Symbol	Values			Unit	Note / Test Condition
		Min.	Typ.	Max.		
Time span from last BSS to FES without the influence of quartz tolerancies (d10Bit_TX) <sup>1)</sup>	$t_{60}$ CC	997.75	–	1002.25	ns	
TxD data valid from fsample flip flop txd_reg TxDA, TxDB (dTxAsym) <sup>2)3)</sup>	$t_{61}$ - $t_{62}$ CC	–	–	1.5	ns	Asymmetrical delay of rising and falling edge (TxDA, TxDB)
Time span between last BSS and FES without influence of quartz tolerancies (d10Bit_RX) <sup>1)4)5)</sup>	$t_{63}$ SR	966	–	1046.1	ns	
RxD capture by fsample (RxDA/RxDB sampling flip-flop) (dRxAsym) <sup>6)</sup>	$t_{64}$ - $t_{65}$ CC	–	–	3.0	ns	Asymmetrical delay of rising and falling edge (RxDA, RxDB)
TxD data delay from sampling flip-flop	$dTxdly$ CC	–	–	10.0	ns	Px_PDR.PDy = 000 <sub>B</sub>
		–	–	15.0	ns	Px_PDR.PDy = 001 <sub>B</sub>
RxD capture delay by sampling flip-flop	$dRxdly$ CC	–	–	10.0	ns	

1) This includes the PLL\_ERAY accumulated jitter.

2) Refers to delays caused by the asymmetries of the output drivers of the digital logic and the GPIO pad drivers. Quartz tolerance and PLL\_ERAY accumulated jitter are not included.

3) E-Ray TxD output drivers have an asymmetry of rising and falling edges of  $|t_{FA2} - t_{RA2}| \leq 1 \text{ ns}$ .

4) Limits of 966ns and 1046.1ns correspond to (30%, 70%) \*  $V_{DDP}$  FlexRay standard input thresholds. For input thresholds of this product, a correction of - 0.5 ns and +0.1 ns has to be applied.

## Electrical Parameters Flash Memory Parameters

- 5) Valid for output slopes of the bus driver of  $dRxSlope \leq 5ns$ ,  $20\% * V_{DDP}$  to  $80\% * V_{DDP}$ , according to the FlexRay Electrical Physical Layer Specification V2.1B. For A2 pads, the rise and fall times of the incoming signal have to satisfy the following inequality:  $-1.6ns \leq t_{FA2} - t_{RA2} \leq 1.3ns$ .
- 6) Valid for output slopes of the bus driver of  $dRxSlope \leq 5ns$ ,  $20\% * V_{DDP}$  to  $80\% * V_{DDP}$ , according to the FlexRay Electrical Physical Layer Specification V2.1B. For A2 pads, the rise and fall times of the incoming signal have to satisfy the following inequality:  $-1.6ns \leq t_{FA2} - t_{RA2} \leq 1.3ns$ .

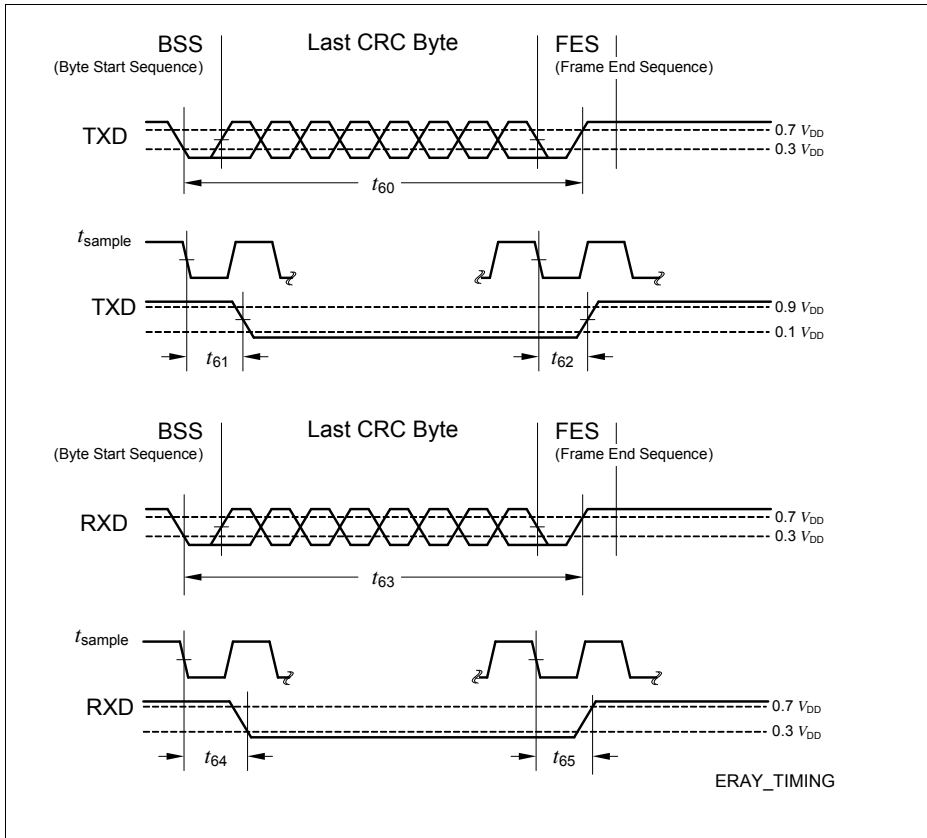

**Figure 25 ERAY Timing**

### 5.4 Flash Memory Parameters

The data retention time of the TC1791's Flash memory depends on the number of times the Flash memory has been erased and programmed.

## Electrical Parameters Flash Memory Parameters

Table 43 FLASH32 Parameters

Parameter	Symbol	Values			Unit	Note / Test Condition
		Min.	Typ.	Max.		
Data Flash Erase Time per Sector	$t_{ERD}$ CC	–	–	4.2 <sup>1)</sup>	s	
Program Flash Erase Time per 256 KByte Sector	$t_{ERP}$ CC	–	–	5	s	
Program time data flash per page <sup>2)</sup>	$t_{PRD}$ CC	–	–	5.3	ms	without reprogramming
		–	–	15.9	ms	with two reprogramming cycles
Program time program flash per page <sup>3)</sup>	$t_{PRP}$ CC	–	–	5.3	ms	without reprogramming
		–	–	10.6	ms	with one reprogramming cycle
Data Flash Endurance	$N_E$ CC	60000 <sup>4)</sup>	–	–	cycle s	Min. data retention time 5 years
Erase suspend delay	$t_{FL\_ErSusp}$ CC	–	–	15	ms	
Wait time after margin change	$t_{FL\_MarginDel}$ CC	10	–	–	μs	
Program Flash Retention Time, Physical Sector <sup>5)6)</sup>	$t_{RET}$ CC	20	–	–	year s	Max. 1000 erase/program cycles
Program Flash Retention Time, Logical Sector <sup>5)6)</sup>	$t_{RETL}$ CC	20	–	–	year s	Max. 100 erase/program cycles
UCB Retention Time <sup>5)6)</sup>	$t_{RTU}$ CC	20	–	–	year s	Max. 4 erase/program cycles per UCB
Wake-Up time	$t_{WU}$ CC	–	–	270	μs	



## Electrical Parameters Flash Memory Parameters

Table 43 FLASH32 Parameters (cont'd)

Parameter	Symbol	Values			Unit	Note / Test Condition
		Min.	Typ.	Max.		
DFlash wait state configuration	$WS_{DF}$ CC	$50\text{ ns} \times$ $f_{FSI}$	–	–		
PFlash wait state configuration	$WS_{PF}$ CC	$26\text{ ns} \times$ $f_{FSI}$	–	–		

- 1) In case of wordline oriented defects (see robust EEPROM emulation in the User's Manual) this erase time can increase by up to 100%.
- 2) In case the Program Verify feature detects weak bits, these bits will be programmed up to twice more. Each reprogramming takes additional 5 ms.
- 3) In case the Program Verify feature detects weak bits, these bits will be programmed once more. The reprogramming takes additional 5 ms.
- 4) Only valid when a robust EEPROM emulation algorithm is used. For more details see the User's Manual.
- 5) Storage and inactive time included.
- 6) At average weighted junction temperature  $T_j = 100^\circ\text{C}$ , or the retention time at average weighted temperature of  $T_j = 110^\circ\text{C}$  is minimum 10 years, or the retention time at average weighted temperature of  $T_j = 150^\circ\text{C}$  is minimum 0.7 years.

## 5.5 Package and Reliability

### 5.5.1 Package Parameters

**Table 44 Thermal Characteristics of the Package**

Device	Package	$R_{\Theta JCT}^{1)}$	$R_{\Theta JCB}^{1)}$	$R_{\Theta JA}$	Unit	Note
TC1791	PG-LFBGA- 292-6	3,73	4,98	15,0	K/W	

1) The top and bottom thermal resistances between the case and the ambient ( $R_{TCAT}$ ,  $R_{TCAB}$ ) are to be combined with the thermal resistances between the junction and the case given above ( $R_{TJCT}$ ,  $R_{TJCB}$ ), in order to calculate the total thermal resistance between the junction and the ambient ( $R_{TJA}$ ). The thermal resistances between the case and the ambient ( $R_{TCAT}$ ,  $R_{TCAB}$ ) depend on the external system (PCB, case) characteristics, and are under user responsibility.

The junction temperature can be calculated using the following equation:  $T_J = T_A + R_{TJA} \times P_D$ , where the  $R_{TJA}$  is the total thermal resistance between the junction and the ambient. This total junction ambient resistance  $R_{TJA}$  can be obtained from the upper four partial thermal resistances.

Thermal resistances as measured by the 'cold plate method' (MIL SPEC-883 Method 1012.1).

### 5.5.2 Package Outline

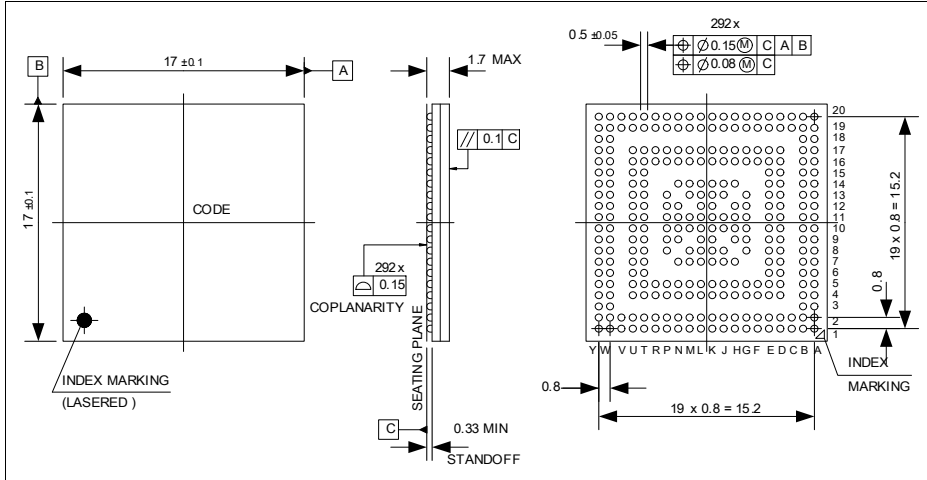

**Figure 26 Package Outlines PG-LFBGA- 292-6**

You can find all of our packages, sorts of packing and others in our Infineon Internet Page “Products”: <http://www.infineon.com/products>.

### 5.5.3 Quality Declarations

**Table 45 Quality Parameters**

Parameter	Symbol	Values			Unit	Note / Test Condition
		Min.	Typ.	Max.		
Operation Lifetime <sup>1)</sup>	$t_{OP}$	–	–	24000	hours	– <sup>2)</sup>
ESD susceptibility according to Human Body Model (HBM)	$V_{HBM}$	–	–	2000	V	Conforming to JESD22-A114-B
ESD susceptibility of the LVDS pins	$V_{HBM1}$	–	–	500	V	–

## Electrical Parameters Package and Reliability

Table 45 Quality Parameters

Parameter	Symbol	Values			Unit	Note / Test Condition
		Min.	Typ.	Max.		
ESD susceptibility according to Charged Device Model (CDM)	$V_{CDM}$	–	–	500	V	Conforming to JESD22-C101-C
Moisture Sensitivity Level	MSL	–	–	3	–	Conforming to Jedec J-STD-020C for 240°C

1) This lifetime refers only to the time when the device is powered on.

2) For worst-case temperature profile equivalent to:

1200 hours at  $T_j = 125...150^\circ\text{C}$

3600 hours at  $T_j = 110...125^\circ\text{C}$

7200 hours at  $T_j = 100...110^\circ\text{C}$

11000 hours at  $T_j = 25...100^\circ\text{C}$

1000 hours at  $T_j = -40...25^\circ\text{C}$

## 6 History

The following changes were done between Version 0.6 and 0.62 of this document:

- add footnote to port 4.1 alternate output 3 MTSR2
- change function description for port 4.1 alternate output 3 MTSR2 from Slave to Master Transmit
- add footnote to port 6.4 alternate output 1 MTSR1
- add footnote to port 7.1 alternate output 2 MTSR3
- change for port 8.3 the symbol from OUT43 (GPTA1) to CC62 (CCU60)
- change for port 17 the type from S to D / S
- add clarification that table 11 defines the conditions for all other parameters
- add conditions for MLI, MSC, SSC, parameters
- add parameters dTxdly and dRxdly to ERAY parameters
- correct footnotes for ERAY parameters
- split flash parameters tPRD and tPRP in two conditions
- add conditions to LVDS pad parameters
- remove Pin Reliability in Overload section
- add parameters IIN and Sum IIN to absolute ratings
- add parameter HYSX to PSC\_XTAL
- added RDSON values for all driver settings (weak, medium, and strong)
- removed footnote 2 of table 10
- change load for timing of SSC, MSC, and MLI from  $C_L = 25$  pF to  $C_L = 50$  pF (typical)
- add to parameters  $t_{RF}$  and  $t_{FF}$  condition  $C_L = 50$  pF
- add new footnote 7) to ADC parameter table
- add min and max value for  $Q_{CONV}$  and adapt typ value
- add load conditions for  $t_{FF1}$  and  $t_{RF1}$
- add conditions to PLL parameter  $t_L$
- change DAP parameter  $t_{i9}$  from SR to CC classification
- remove footnote 2 for the FADC
- adapt IDs for AB step
- 
- removed footnote 2 in table 11
- change max value for ADC parameter  $t_S$  from 255 to 257
- 
- switch input function ECTT1 and ECTT2
- add input function REQ15 to P9.14
- add alternate output O1 for OUT97 of GPTA0
- changed the name for O3 from EVTO2 to EVTO1 for P0.5
- changed the name for O3 from EVTO3 to EVTO2 for P0.6
- changed the name for O3 from EVTO4 to EVTO3 for P0.7
- add input function SLSI2 for SSC2 to P4.9

The following changes were done between Version 0.62 and 0.63 of this document:

- switch input function ECTT1 and ECTT2
- add input function REQ15 to P9.14
- add alternate output O1 for OUT97 of GPTA0
- changed the name for O3 from EVTO2 to EVTO1 for P0.5
- changed the name for O3 from EVTO3 to EVTO2 for P0.6
- changed the name for O3 from EVTO4 to EVTO3 for P0.7
- add input function SLSI2 for SSC2 to P4.9
- change for port 6.15 the symbol from CC61(CCU60) to CC60(CCU61)
- change for port 8.2 the symbol from CC61(CCU60) to COUT63(CCU61)
- add to all SSC signal the associated SSC module where it was missing in the pinning
- add section Pin Reliability in Overload
- increase values for absolute maximum parameters  $I_{IN}$  and  $\text{Sum}I_{IN}$
- correct P14.8 O2 as this was an incorrect label as O1
- add to P4.9 output function OUT1 for LTCA2

The following changes were done between Version 0.63 and 0.7 of this document:

- update value of RTID registers in section Identification Registers for AB step
- remove sentence 'Exposure to conditions within the maximum ratings will not affect device reliability. To replace this sentence section Pin Reliability in Overload was added.
- add footnote 1 to table 12 (Operating Conditions)
- increase values for absolute maximum parameters  $I_{IN}$  and  $\text{Sum}I_{IN}$
- remove capacitance conditions for LVDS pad parameters as loads are defined by interface (MSC) timings
- add parameter  $V_{ILSD}$  for class S pads
- add  $V_{DDM}$  supply limitation for class S parameters
- add footnote 10 to table 23 (ADC parameters)
- remove old footnote 2 from table 24 (FADC parameters)
- remove term typical from load of Peripheral Timings
- add definition of driver strength settings for ERAY Interface Timing
- update formulas for frequency modulation
- change SSC parameter from  $t_{59}$  CC to SR
- change footnote 4 wording for ERAY timing back to TC1797 wording
- increase flash parameters  $t_{PRD}$  and  $t_{PRP}$  values
- increase flash parameter  $t_{ERD}$
- add section 5.2.6.1.
- change in legend of table 2 definition of class S pad
- correct section Extended Range Operating Conditions for the 3.3 V area
- increase limit in Extended Range Operating Conditions from 1 hour to 1000 hours
- specify wording for limitation of pad performance in section Extended Range Operating Conditions
- remove incorrect test conditions for RDSONx parameters
- adjust typo in temperature profile

## History

- removed RDSON parameters for class F pads weak driver as only medium is available
- add parameter  $f_{\text{SYS}}D$  for the SYSPLL
- update all current values of table 28 (Power Supply Parameters)
- rework the 3.3 V current part of the Power Supply Parameters for better description and usage
  - Parameters  $I_{\text{DDP\_FP}}$ ,  $I_{\text{DDFL3E}}$  and  $I_{\text{DDFL3R}}$  are removed and replaced in the following way
  - $I_{\text{DDP\_FP}}$  is replaced by  $I_{\text{DDP}}$  with the condition including flash programming current
  - $I_{\text{DDFL3E}}$  is replaced by  $I_{\text{DDP}}$  with the condition including flash erase verify current
  - $I_{\text{DDFL3R}}$  is replaced by  $I_{\text{DDP}}$  with the condition including flash read current
  - parameter  $I_{\text{DDFL3R}}$  was renamed to  $I_{\text{DDFL3}}$

The rework of the 3.3 V current part of the Power Supply Parameters was done for simplification and clarification. Former given values could still be used if liked, the new definition results in the same resulting values or slightly better values. The flash module is supplied via  $I_{\text{DDFL3}}$  and  $I_{\text{DDP}}$ . For the different flash operating modes in worst case different allocations for the two domains resulting.

The application typical case 'flash read' has max  $I_{\text{DDP}}$  of 25 mA and max  $I_{\text{DDFL3}}$  of 98 mA resulting is a sum of 123 mA.

The case 'flash programming' has max  $I_{\text{DDP}}$  of 55 mA and max  $I_{\text{DDFL3}}$  of 29 mA resulting is a sum of 84 mA.

The case 'flash erase verify' has max  $I_{\text{DDP}}$  of 40 mA and max  $I_{\text{DDFL3}}$  of 98 mA resulting is a sum of 138 mA.

So for the old parameter  $I_{\text{DDP}}$  with 35 mA, the new version reads as  $I_{\text{DDP}} = 25 + I_{\text{DDP\_PORST}} = 32$  mA for the same application relevant case.

The following changes were done between Version 0.7 and 1.0 of this document:

- add product options **SAK-TC1791S-512F240EP**, **SAK-TC1791S-384F200EP**, and **SAK-TC1791N-384F200EP**
- update block diagrams to cover new options
- add note to TC1791 Logic Symbol figure and pin list for E-RAY pins availability
- add identification registers for new options
- adapt Absolute Maximum Rating
- clarify pad supply levels in Pin Reliability in Overload section
- correct errors for analog inputs in tables 12 and 13
- add note at the end of Pin Reliability in Overload section
- clarify wording for valid operating conditions
- add negative limit for class S pad leakage
- change description of parameter  $t_{\text{CAL}}$  for the ADC
- update footnote 10 for the ADC
- split FADC DNL parameter into two conditions and change value for gain 4 and 8
- add footnote 5 to  $I_{\text{DDP}}$

- improve parameters  $I_{DDFL3}$
- add footnote for D-Flash currents in power section
- rework first sentence for chapter 5.3
- increase max values for parameter  $t_B$
- reduce min value for  $t_L$  for both PLLs
- split  $f_{VCO}$  for the system PLL into two conditions
- change formula 10
- add for MLI and SSC timing parameter: valid strong driver medium edge only
- change MLI parameter  $t_{17}$  min value
- update parameter description for SSC parameters  $t_{52}$ ,  $t_{53}$ ,  $t_{56}$ ,  $t_{57}$ ,  $t_{58}$ , and  $t_{59}$
- change SSC parameters from CC to SR Symbol for  $t_{56}$ ,  $t_{57}$ ,  $t_{58}$  and  $t_{59}$
- add note to ERAY parameters for availability
- add footnote to Flash parameter  $t_{ERD}$
- change for parameter  $N_E$  note from Max. data retention to Min.

The following changes were done between Version 1.0 and 1.1 of this document:

- remove the following product options:
  - SAK-TC1791N-384F200EL
- change  $V_{ILS}$  from 2.1V to 1.9V in table 25
- change  $t_{48}$  from 100ns to 200ns in table 40
- change  $t_{49}$  from 100ns to 200ns in table 40
- extend  $K_{OVAN}$  condition from  $I_{OV} \leq 0$  mA;  $I_{OV} \geq -1$  mA to  $I_{OV} \leq 0$  mA;  $I_{OV} \geq -2$  mA
- change package version from PG-LFBGA-292-3 to PG-LFBGA-292-6



[www.infineon.com](http://www.infineon.com)

Published by Infineon Technologies AG