

ELM842xC 140µA Low power class-A output CMOS operational amplifier

<http://www.elm-tech.com>

■ General description

ELM842xC is a low current consumption-Typ.140µA CMOS OP-AMP provided with a wide common mode input voltage range. It has a quasi rail-to-rail input stage and a class-A rail-to-rail output stage. ELM842xC can operate down to 1.2V. ELM842xC is suitable for portable devices which require low power and a single voltage source.

■ Features

- Operation from a single power source
- Low voltage operation : $1.2V \leq V_{dd} \leq 6.0V$
- Low current consumption : Typ.130µA($V_{dd}=1.5V$)
- N-channel depletion differential input
 - : No gm dependence on input operating points
- Common-mode input voltage range
 - : Quasi rail-to-rail input
 - 0.08V to $V_{dd}-0.05V$ ($V_{dd}=1.5V$)
 - 0.04V to $V_{dd}-0.1V$ ($V_{dd}=3.0V$)
- Output stage : 90µA Class-A rail-to-rail output
- Unity gain bandwidth : Typ.1MHz($V_{dd} \geq 1.5V$)
- Package : SOT-25, SC-70-5(SOT-353)

■ Application

- Battery-operated portable devices
- Signal process in low power circuit
- Low voltage analog circuit

■ Maximum absolute ratings

Parameter	Symbol	Limit	Unit
Power supply voltage	V _{dd}	7.0	V
Input voltage	V _{in}	V _{ss} -0.3 to V _{dd} +0.3	V
Output voltage	V _{out}	V _{ss} -0.3 to V _{dd} +0.3	V
Output short circuit		Continuous	Sec.
Power dissipation	P _d	300 (SOT-25)	mW
		150 (SC-70-5(SOT-353))	
Operating temperature	T _{op}	-40 to +85	°C
Storage temperature	T _{stg}	-55 to +125	°C

■ Selection guide

ELM842xC-x

Symbol		
a	Package	B: SOT-25 C: SC-70-5(SOT-353)
b	Product version	C
c	Taping direction	S, N: Refer to PKG file

ELM842 x C - x
 ↑ ↑ ↑
 a b c

ELM842xC 140 μ A Low power class-A output CMOS operational amplifier

<http://www.elm-tech.com>

■ Pin configuration

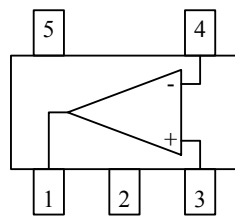

Pin No.	Pin name
1	OUT
2	VDD
3	IN+
4	IN-
5	VSS

■ Standard circuit

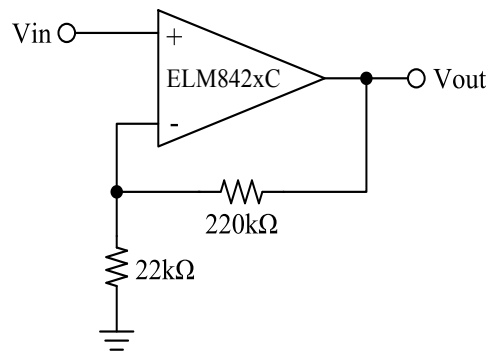

■ Marking

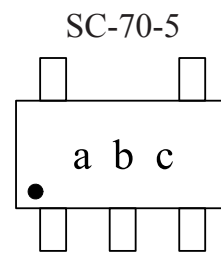
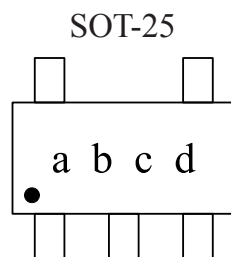

Symbol	Mark	Content
a, b	5 C	ELM842BC (SOT-25)
	> 2	ELM842CC (SC-70-5)
c	0 to 9 and A to Z (I, O, X excepted.)	Lot No.
d	0 to 9 and A to Z (I, O, X excepted.)	Lot No.

ELM842xC 140 μ A Low power class-A output CMOS operational amplifier

<http://www.elm-tech.com>

■Electrical characteristics

V_{ss}=0V, Top=-40~+85°C

Parameter	Symbol	Condition	Min.	Typ.	Max.	Unit
Operating voltage	V _{dd}		1.2		6.0	V

V_{dd}=1.5V

V_{ss}=0V, Top=25°C

Parameter	Symbol	Condition	Min.	Typ.	Max.	Unit
Input offset voltage	V _{io}	V _{cm} =V _{dd} /2, Unity gain follower			±6	mV
Input bias current	I _{ib}				1.0	nA
Common-mode input voltage range	V _{cmr}	For CMRR≥40dB	0.08		1.45	V
Maximum output voltage swing	V _{outsh}	V _{id} =100mV, R _L =200kΩ to V _{ss}	1.42			V
Minimum output voltage swing	V _{outsl}	V _{id} =100mV, R _L =10kΩ to V _{dd}			0.10	V
Source current	I _{source}	V _{out} =0.75V, V _{id} =100mV	40	90		μA
Sink current	I _{sink}	V _{out} =0.3V, V _{id} =100mV	1.0	2.5		mA
Large-signal voltage gain	A _{vd}	R _L =200kΩ to V _{ss} , V _{cm} =0.75V		110		dB
Common-mode rejection ratio	CMRR	R _L =200kΩ to V _{ss} , V _{cm} =0.75V		90		dB
Supply voltage rejection ratio	PSRR	R _L =200kΩ to V _{ss} , V _{cm} =0.75V		70		dB
Current consumption	I _{ss}	V _{cm} =V _{dd} /2, Unity gain follower		130	310	μA
Short current	I _{shortp}	V _{out} to V _{ss} shrot, V _{id} =100mV		100		μA
	I _{shortn}	V _{out} to V _{dd} shrot, V _{id} =100mV		4.0		mA
Unity gain bandwidth	GBW			1		MHz
Slew rate	SR	R _L =200kΩ, C _L =20pF	0.45	1.00		V/μs

V_{dd}=3.0V

V_{ss}=0V, Top=25°C

Parameter	Symbol	Condition	Min.	Typ.	Max.	Unit
Input offset voltage	V _{io}	V _{cm} =V _{dd} /2, Unity gain follower			±6	mV
Input bias current	I _{ib}				1.0	nA
Common-mode input voltage range	V _{cmr}	For CMRR≥40dB	0.04		2.90	V
Maximum output voltage swing	V _{outsh}	V _{id} =100mV, R _L =200kΩ to V _{ss}	2.80			V
Minimum output voltage swing	V _{outsl}	V _{id} =100mV, R _L =10kΩ to V _{dd}			0.10	V
Source current	I _{source}	V _{out} =1.5V, V _{id} =100mV	45	100		μA
Sink current	I _{sink}	V _{out} =0.3V, V _{id} =100mV	3.0	7.5		mA
Large-signal voltage gain	A _{vd}	R _L =200kΩ to V _{ss} , V _{cm} =1.5V		110		dB
Common-mode rejection ratio	CMRR	R _L =200kΩ to V _{ss} , V _{cm} =1.5V		110		dB
Supply voltage rejection ratio	PSRR	R _L =200kΩ to V _{ss} , V _{cm} =1.5V		100		dB
Current consumption	I _{ss}	V _{cm} =V _{dd} /2, Unity gain follower		140	360	μA
Short current	I _{shortp}	V _{out} to V _{ss} shrot, V _{id} =100mV		110		μA
	I _{shortn}	V _{out} to V _{dd} shrot, V _{id} =100mV		25		mA
Unity gain bandwidth	GBW			1		MHz
Slew rate	SR	R _L =200kΩ, C _L =20pF	0.45	1.00		V/μs

ELM842xC 140µA Low power class-A output CMOS operational amplifier

<http://www.elm-tech.com>

■Note

1) Load resistance

ELM842xC is designed for low power consumption applications; hence, the output source current is only 90µA (Typ. under the conditions of at $V_{dd}=1.5V$, $V_{out}=0.75V$ and $T_{op}=25^{\circ}C$). As a result, ELM842xC is not able to maintain output voltage swing when trying to drive small load resistance. Considering this, load and feedback resistance for ELM842xC should be selected carefully.

ELM recommends the following load/feedback resistors depending on power supply voltage range.

< Power supply voltage >	< total resistance value of load/feedback resistor >
$V_{dd} \leq 5.5V$	$R \geq 250k\Omega$
$V_{dd} \leq 3.6V$	$R \geq 200k\Omega$
$V_{dd} \leq 1.8V$	$R \geq 150k\Omega$

2) Operation from single power source

ELM842xC is designed to be most suitable for single power source; therefore, ELM842xC is able to share power supply with logic circuit one. Meanwhile, ELM842xC can also operate from double power sources. To protect power supplies of ELM842xC and logic circuit from noise, please separate wire from power supply and use decoupling (bypass) capacitor. Using the capacitor can improve PSRR characteristics, especially on 10kHz to 100kHz or more.

3) Feedback

When OP-AMP circuit is used with feedback resistor, oscillation may happen in the circuit with loop-gain like unity gain follower.

a) When large feedback resistance is used, the phase margin is decreased by its combination with the parasitic capacitance of the input part of OP-AMP. In this situation, please connect small capacitor in parallel with feedback resistor as shown in fig-1.

b) For capacitive load, external resistor in series connection will be effective as shown in fig-2.

($R_L=300$ to 500Ω)

c) Being used as an unity gain follow, ELM842xC is able to drive capacitive load of 100pF directly without oscillation.

a) fig-1

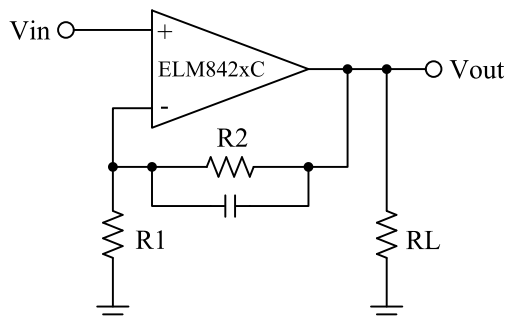

b) fig-2

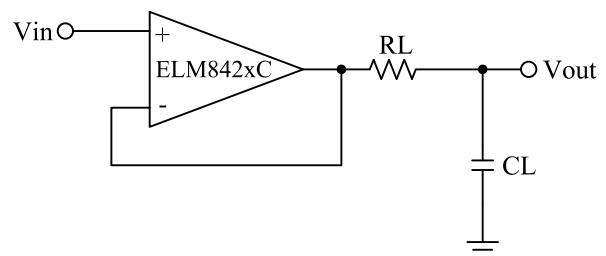

4) Operation at $V_{dd} < 1.2V$

ELM842xC is able to maintain operation when supply voltage is below 1.2V ($V_{dd} \geq 1.2V$) since all input voltage is acceptable within the range of power supply voltage. However, AC characteristics will become weak under this situation because of the decrease of bias current in the IC. For further information, please contact ELM.

ELM842xC 140 μ A Low power class-A output CMOS operational amplifier

<http://www.elm-tech.com>

■ Typical characteristics

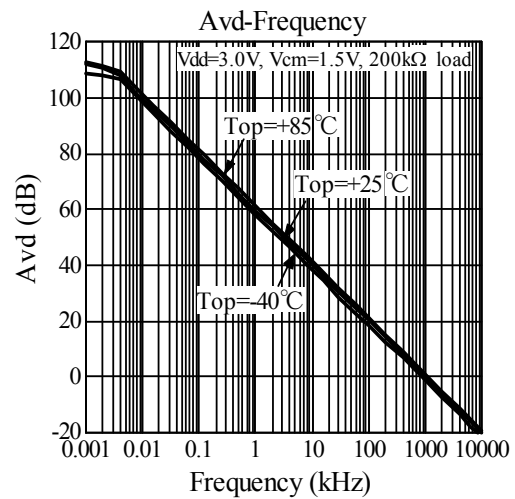
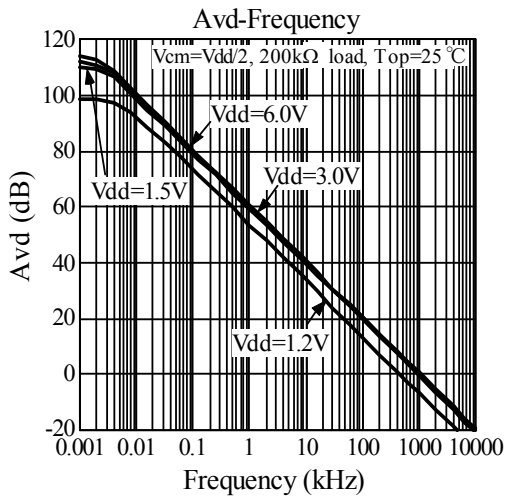
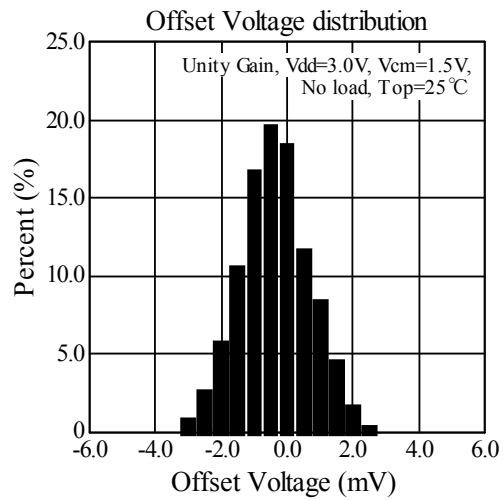
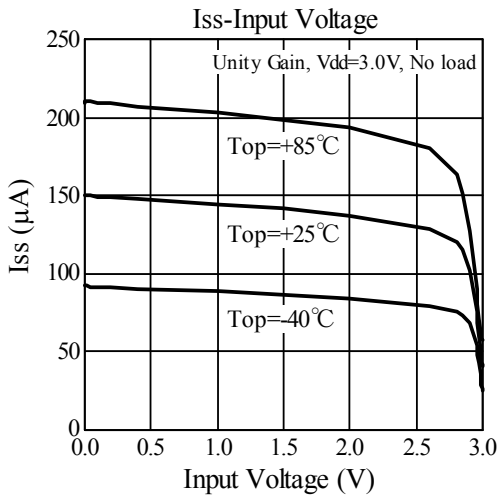
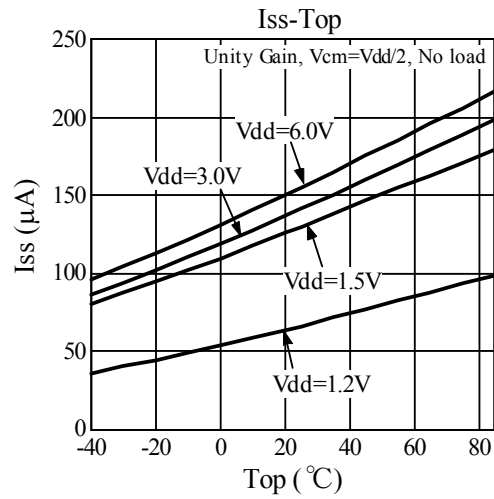
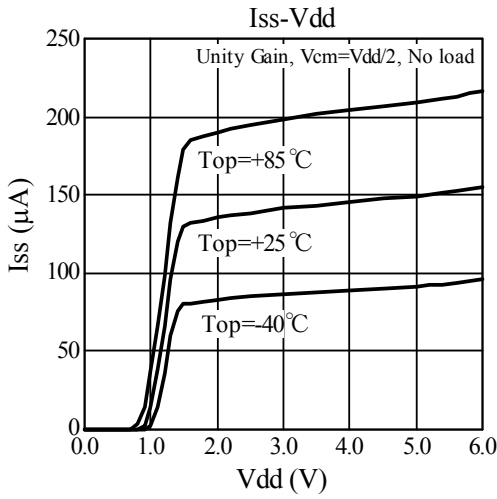

ELM842xC 140 μ A Low power class-A output CMOS operational amplifier

<http://www.elm-tech.com>

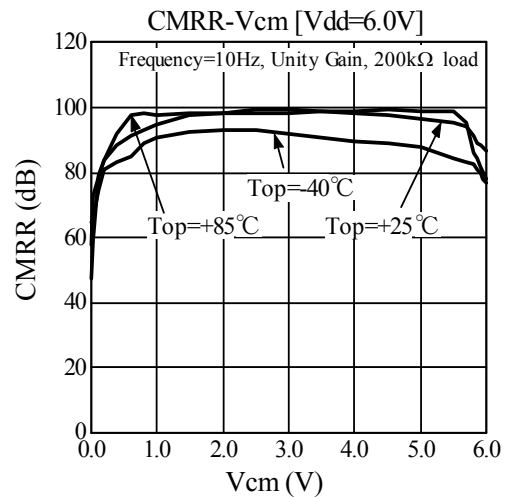
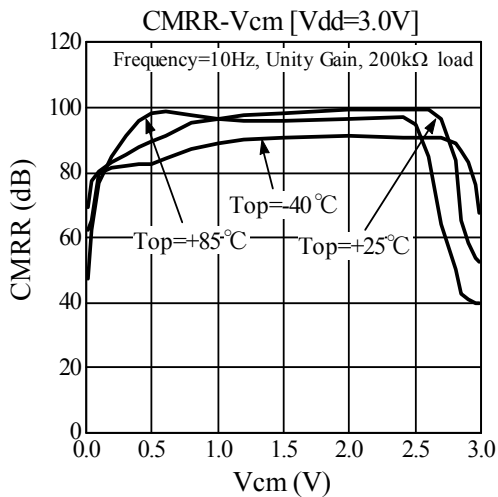
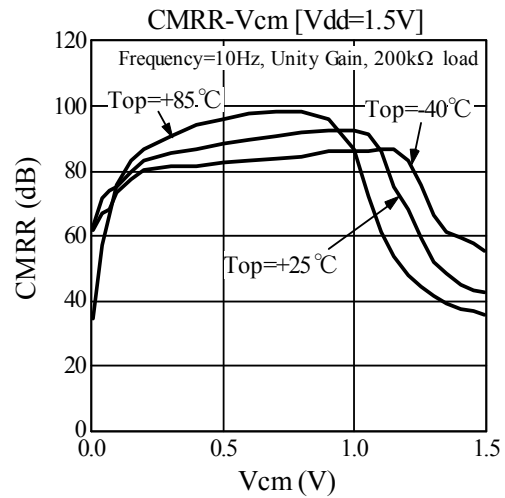
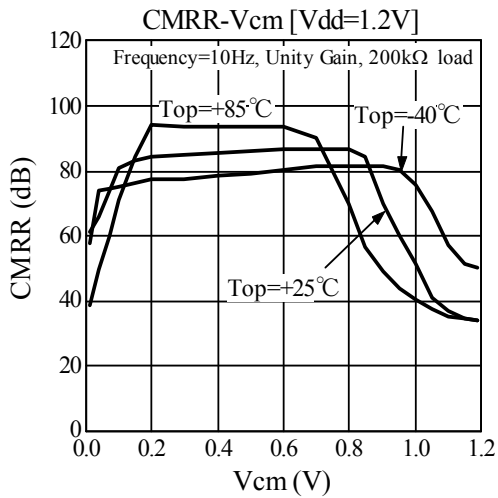
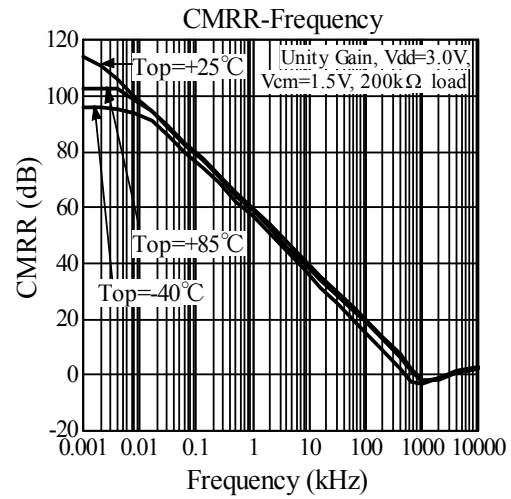
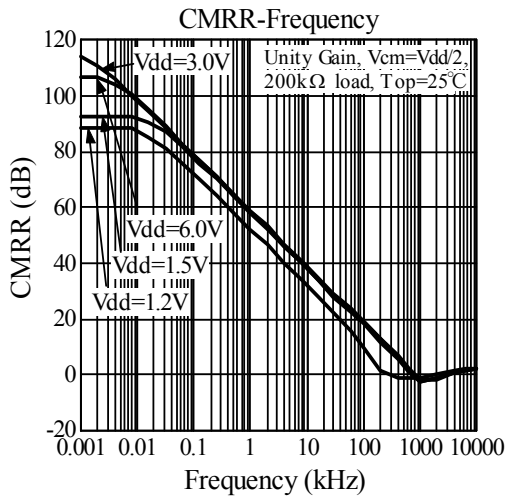

ELM842xC 140 μ A Low power class-A output CMOS operational amplifier

<http://www.elm-tech.com>

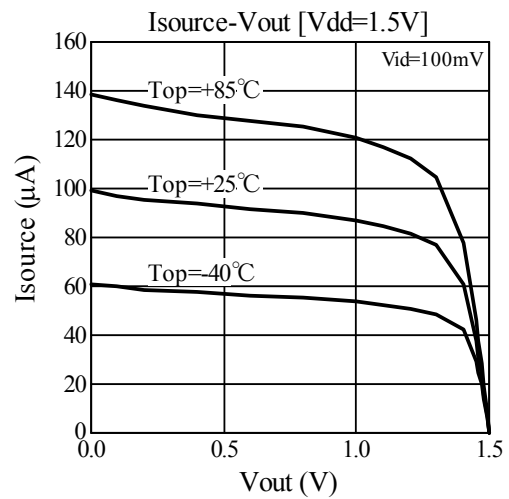
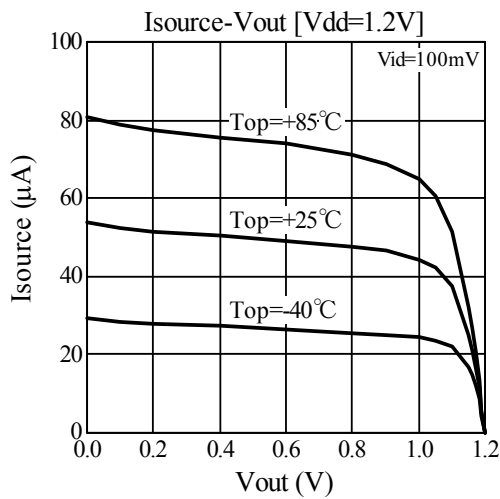
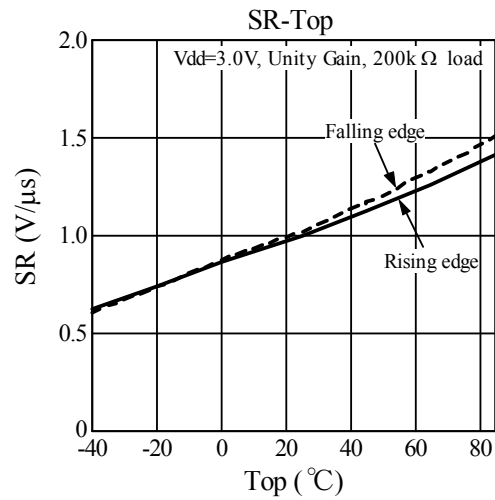
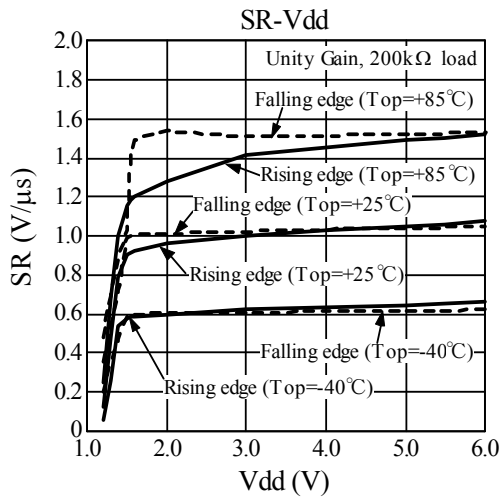
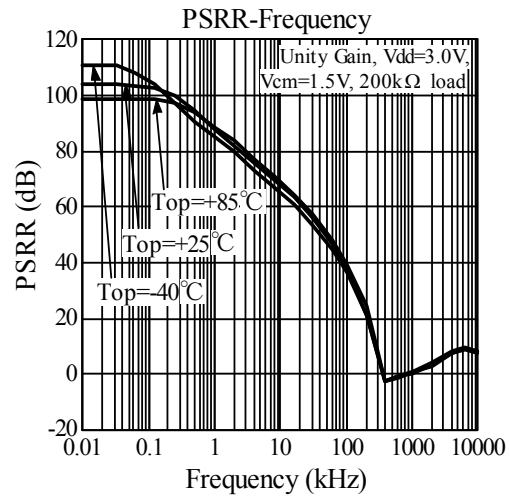
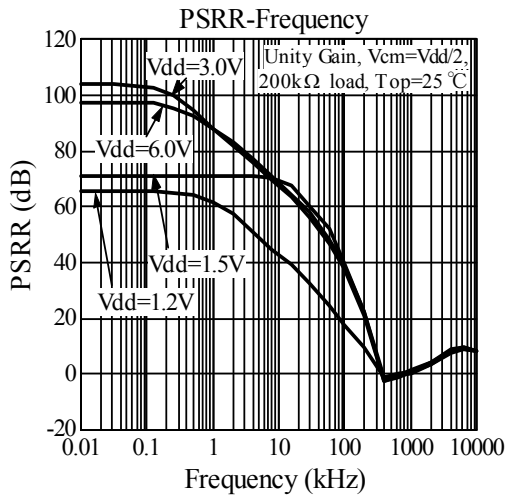

ELM842xC 140 μ A Low power class-A output CMOS operational amplifier

<http://www.elm-tech.com>

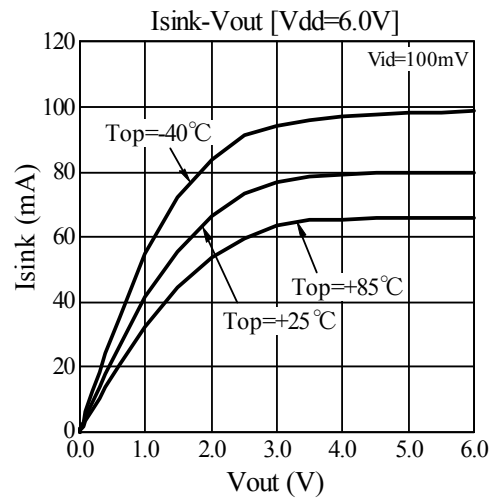
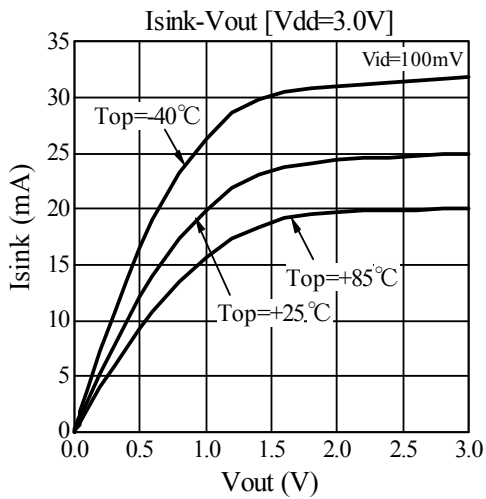
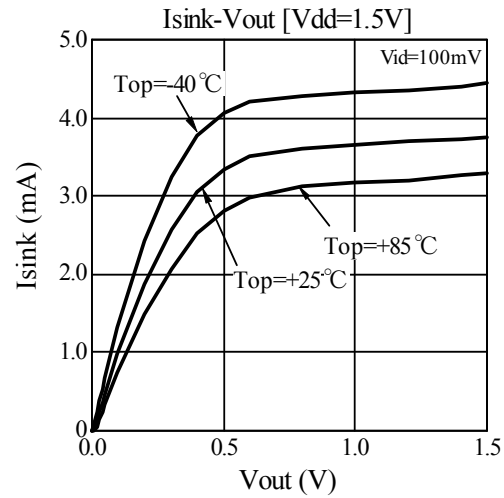
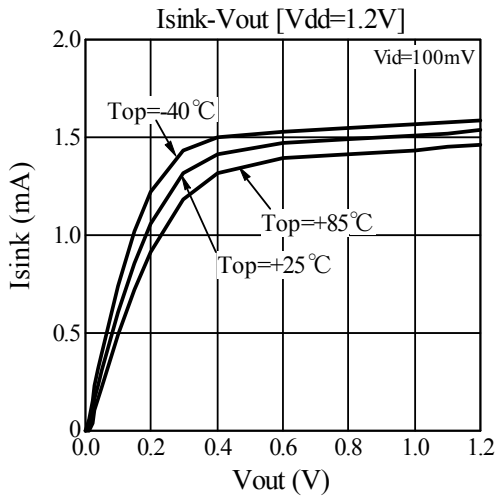
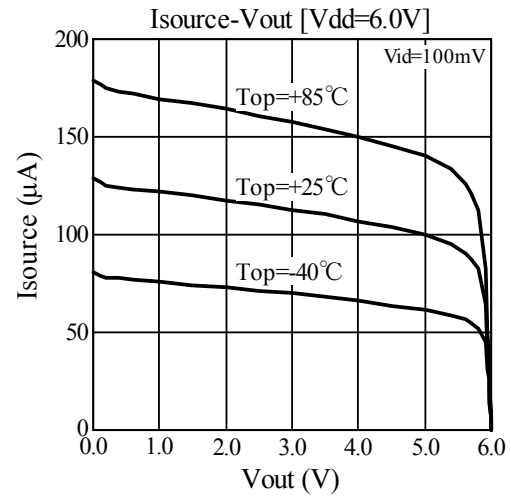
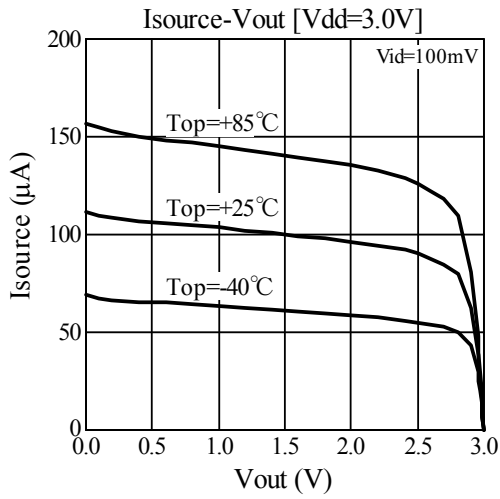

ELM842xC 140 μ A Low power class-A output CMOS operational amplifier

<http://www.elm-tech.com>

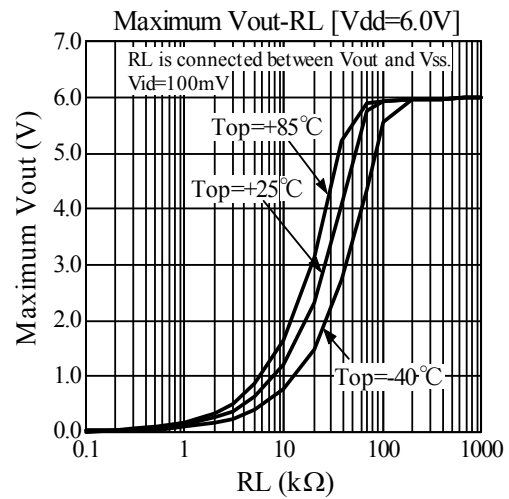
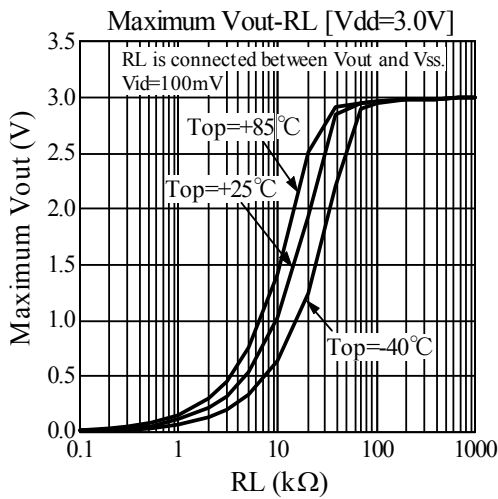
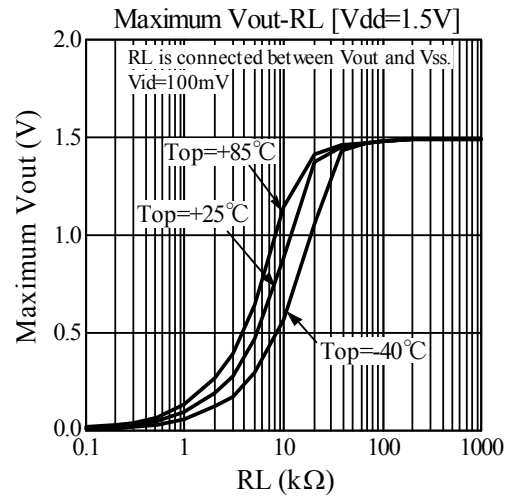
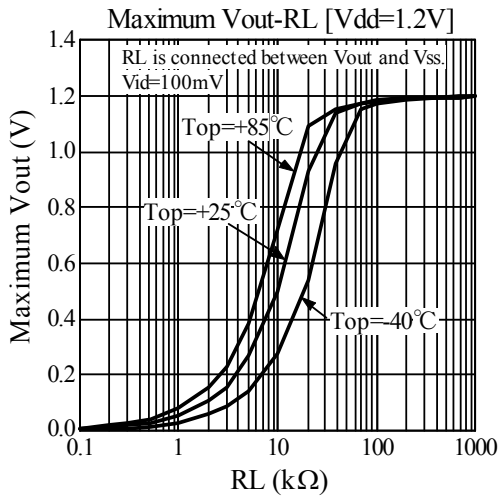
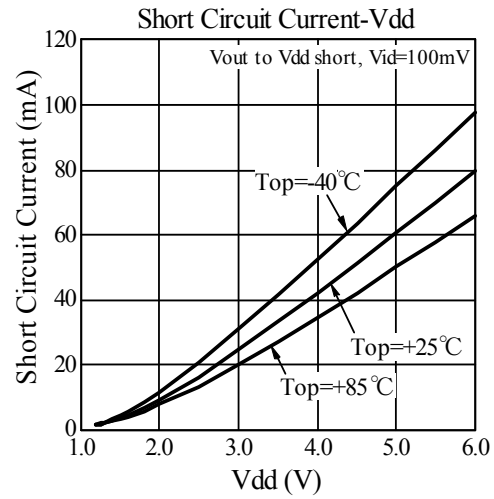
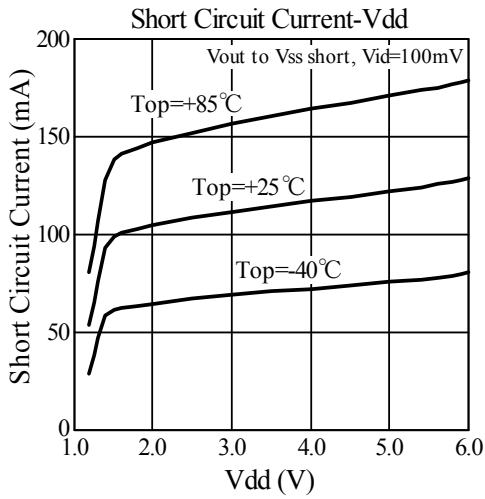

ELM842xC 140 μ A Low power class-A output CMOS operational amplifier

<http://www.elm-tech.com>

