

Wall Industries, Inc.

LANCUW8 SERIES

**4:1 Ultra Wide Input Voltage Ranges
Single and Dual Outputs
SMT and DIP Packages
8 Watt DC/DC Power Converters**



APPLICATIONS

- Railway Systems
- Wireless Networks
- Telecom / Datacom
- Measurement Equipment
- Industry Control Systems
- Semiconductor Equipment

FEATURES

- Single and Dual Outputs
- 4:1 Ultra Wide Input Voltage Ranges
- High Efficiency up to 88%
- 8 Watts Output Power
- 1600VDC I/O Isolation
- Output Current up to 2.4A
- Remote ON/OFF
- Fixed Switching Frequency (300KHz)
- Over Voltage, Over Load, and Short Circuit Protection
- Five-Sided Continuous Shield
- Railway Applications
- Standard 1.25" x 0.80" x 0.40" and 24 Pin DIP Package
- SMT Package Available (Suffix "S")
- Compliant to RoHS EU Directive 2002/95/EC
- CE Mark Meets 2006/95/EC, 93/68/EEC and 2004/108/EC
- UL60950-1, EN60950-1, IEC60950-1, and EN50155 Safety Approvals (Pending)

DESCRIPTION

The LANCUW8 series of DC/DC power converters provides 8 Watts of output power in a 1.25 x 0.80 x 0.40 inch DIP package. This series has single and dual output models with 4:1 wide input voltage ranges of 9-36VDC, 18-75VDC, and 43-160VDC. Some features include high efficiency up to 88%, 1600VDC I/O isolation, five-sided shielding, remote ON/OFF control, and no minimum load requirement. These converters are also protected against over voltage (single outputs only), over load, and short circuit conditions. All models are RoHS compliant and have UL60950-1, EN60950-1, IEC60950-1, and EN50155 safety approvals (pending). This series is best suited for use in wireless networks, telecom/datacom, measurement equipment, industry control systems, semiconductor equipment, and railway systems.

SPECIFICATIONS: LANCUW8 Series							
All specifications are based on 25°C, Nominal Input Voltage, and Maximum Output Current unless otherwise noted. We reserve the right to change specifications based on technological advances.							
SPECIFICATION	TEST CONDITIONS		Min	Nom	Max	Unit	
INPUT SPECIFICATIONS							
Input Voltage Range	24VDC nominal input models		9	24	36	VDC	
	48VDC nominal input models		18	48	75		
	110VDC nominal input models		43	110	160		
Input Surge Voltage (100ms max)	24VDC nominal input models				50	VDC	
	48VDC nominal input models				100		
	110VDC nominal input models				170		
Start-Up Voltage	24VDC nominal input models				9	VDC	
	48VDC nominal input models				18		
	110VDC nominal input models				43		
Shutdown Voltage	24VDC nominal input models			8		VDC	
	48VDC nominal input models			16			
	110VDC nominal input models			42			
Input Reflected Ripple Current	Nominal Vin and full load			20		mAp-p	
Remote ON/OFF (See Note 6)	DC/DC ON		Open or 3.0V < Vr < 12V				
	DC/DC OFF		Short or 0V < Vr < 1.2V				
Input Current of Remote Control Pin	Nominal Vin		-0.5		+0.5	mA	
Remote Off State Input Current	Nominal Vin			2.5		mA	
Input Filter						Pi type	
OUTPUT SPECIFICATIONS							
Output Voltage						See Table	
Line Regulation	Low line to high line at full load		-0.2		+0.2	%	
Load Regulation	No load to full load	Single Output (DIP)	-0.5		+0.5	%	
		Single Output (SMT)	-1		+1		
		Dual Output (DIP & SMT)	-1		+1		
	10% load to 90% load	Single Output (DIP)	-0.3		+0.3	%	
		Single Output (SMT)	-0.8		+0.8		
		Dual Output (DIP & SMT)	-0.8		+0.8		
Cross Regulation (Dual Outputs)	Asymmetrical load 25% / 100% full load		-5		+5	%	
Voltage Accuracy	Full load an nominal Vin		-1		+1	%	
Output Power						8	W
Output Current						See Table	
Ripple & Noise	20MHz Bandwidth					See Table	
Transient Response Recovery Time	25% load step change			250		µs	
Start-Up Time	Nom. Vin and constant resistive load	Power Up		450		ms	
Minimum Load			0			%	
Temperature Coefficient			-0.02		+0.02	%/°C	
PROTECTION							
Over Load Protection	% of full load at nominal input			150		%	
Short Circuit Protection						Continuous, automatic recovery	
Over Voltage Protection (Single Outputs only)	3.3V output model			3.9		VDC	
	5.0V output model			6.2			
	12V output model			15			
	15V output model			18			
GENERAL SPECIFICATIONS							
Efficiency	Nominal Vin and full load		See Table				
Switching Frequency				300		KHz	
Isolation Voltage	Input to Output (DIP & SMT)		1600			VDC	
	Input (Output) to Case (DIP)		1600				
	Input (Output) to Case (SMT)		1000				
Isolation Resistance			10			GΩ	
Isolation Capacitance					1500	pF	
ENVIRONMENTAL SPECIFICATIONS							
Operating Ambient Temperature (See Note 7)	5V, 12V, 15V, ±12V, & ±15V output models	without derating	-40		+78	°C	
		with derating	+78		+105		
	3.3V and ±5V output models	without derating	-40		+70	°C	
		with derating	+70		+105		
Maximum Case Temperature					+105	°C	
Storage Temperature			-55		+125	°C	
Relative Humidity			5		95	% RH	
Thermal Shock						EN61373, MIL-STD-810F	
Vibration						EN61373, MIL-STD-810F	
Thermal Impedance	Natural Convection			20		°C/Watt	
MTBF (See Note 1)	BELLCORE TR-NWT-000332			2,350,000 hours			
	MIL-HDBK-217F			1,078,000 hours			
PHYSICAL SPECIFICATIONS							
Weight						0.62oz (18g)	
Case Material						Nickel-coated copper	
Base Material						Non-conductive black plastic	
Potting Material						Epoxy (UL94-V0)	
Dimensions (L x W x H)						1.25 x 0.80 x 0.40 inches (31.8 x 20.3 x 10.2 mm)	
SAFETY & EMC CHARACTERISTICS							
Safety Approvals (Pending)						IEC60950-1, UL60950-1, EN60950-1, EN50155	
EMI (See Note 8)	EN55022, EN55011		Class A				
ESD	EN61000-4-2	Air	±8KV			Perf. Criteria A	
		Contact	±6KV				
Radiated Immunity	EN61000-4-3		20 V/m			Perf. Criteria A	
Fast Transient (See Note 9)	EN61000-4-4		±2KV			Perf. Criteria A	
Surge (See Note 9)	EN61000-4-5		±2KV			Perf. Criteria A	
Conducted Immunity	EN61000-4-6		10 Vrms			Perf. Criteria A	

MODEL SELECTION TABLES

SINGLE OUTPUT MODELS										
Model Number	Input Voltage Range	Output Voltage	Output Current		Input Current		Output ⁽⁴⁾ Ripple & Noise	Output Power	Efficiency ⁽⁴⁾	Maximum ⁽⁵⁾ Capacitive Load
			Min. Load	Full Load	No Load ⁽³⁾	Full Load ⁽²⁾				
LANC2433UW8	24 VDC (9 - 36 VDC)	3.3 VDC	0mA	2400mA	40mA	407mA	50mVp-p	8W	85%	1330µF
LANC2405UW8		5 VDC	0mA	1600mA	40mA	402mA	50mVp-p	8W	87%	1330µF
LANC2412UW8		12 VDC	0mA	666mA	25mA	407mA	50mVp-p	8W	86%	288µF
LANC2415UW8		15 VDC	0mA	533mA	25mA	407mA	50mVp-p	8W	86%	200µF
LANC4833UW8	48 VDC (18 - 75 VDC)	3.3 VDC	0mA	2400mA	20mA	204mA	50mVp-p	8W	85%	1330µF
LANC4805UW8		5 VDC	0mA	1600mA	20mA	201mA	50mVp-p	8W	87%	1330µF
LANC4812UW8		12 VDC	0mA	666mA	13mA	201mA	50mVp-p	8W	87%	288µF
LANC4815UW8		15 VDC	0mA	533mA	13mA	198mA	50mVp-p	8W	88%	200µF
LANC11033UW8	110 VDC (43 - 160 VDC)	3.3 VDC	0mA	2400mA	8mA	82mA	75mVp-p	8W	84%	1330µF
LANC11005UW8		5 VDC	0mA	1600mA	8mA	90mA	75mVp-p	8W	85%	1330µF
LANC11012UW8		12 VDC	0mA	666mA	4mA	88mA	75mVp-p	8W	86%	288µF
LANC11015UW8		15 VDC	0mA	533mA	4mA	88mA	75mVp-p	8W	86%	200µF

DUAL OUTPUT MODELS										
Model Number	Input Voltage Range	Output Voltage	Output Current		Input Current		Output ⁽⁶⁾ Ripple & Noise	Output Power	Efficiency ⁽⁴⁾	Maximum ⁽⁵⁾ Capacitive Load
			Min. Load	Full Load	No Load ⁽³⁾	Full Load ⁽²⁾				
LANC2405DUW8	24 VDC (9 - 36 VDC)	±5 VDC	0mA	±800mA	20mA	417mA	50mVp-p	8W	84%	±900µF
LANC2412DUW8		±12 VDC	0mA	±333mA	25mA	407mA	50mVp-p	8W	86%	±133µF
LANC2415DUW8		±15 VDC	0mA	±267mA	25mA	407mA	50mVp-p	8W	86%	±90µF
LANC4805DUW8	48 VDC (18 - 75 VDC)	±5 VDC	0mA	±800mA	10mA	208mA	50mVp-p	8W	84%	±900µF
LANC4812DUW8		±12 VDC	0mA	±333mA	13mA	201mA	50mVp-p	8W	87%	±133µF
LANC4815DUW8		±15 VDC	0mA	±267mA	13mA	201mA	50mVp-p	8W	87%	±90µF
LANC11005DUW8	110 VDC (43 - 160 VDC)	±5 VDC	0mA	±800mA	5mA	93mA	75mVp-p	8W	82%	±900µF
LANC11012DUW8		±12 VDC	0mA	±333mA	5mA	90mA	75mVp-p	8W	85%	±133µF
LANC11015DUW8		±15 VDC	0mA	±267mA	5mA	90mA	75mVp-p	8W	85%	±90µF

NOTES

- BELLCORE TR-NWT-000332. Case 1: 50% Stress, Temperature at 40°C.
MIL-HDBK-217F Notice2 @Ta=25°C, Full load (Ground, Benign, controlled environment).
- Maximum value at nominal input voltage and full load.
- Typical value at nominal input voltage and no load.
- Typical value at nominal input voltage and full load.
- Test by minimum Vin and constant resistive load.
- The ON/OFF control pin voltage is referenced to -Vin.
- Operating Ambient Temperature:
Converters can meet the railway T2 and TX temperature requirements.
T2: -40°C to +70°C for all models, TX: -40°C to +85°C with power derating to 55% output power.
- The LANCW8 series can meet EN55022 and EN55011 Class A with an external capacitor on the input pins to the converter.
Recommended: 24Vin Models: 1µF/50V 1210 MLCC
48Vin Models: 0.47µF/100V 1812 MLCC
110Vin Models: 1µF/250V*2pcs 1812 MLCC
- An external input filter capacitor is required if the module has to meet EN61000-4-4, EN61000-4-5.
Recommended: 24Vin & 48Vin Models: Nippon chemi-con KY series, 220µF/100V
110Vin Models: Nippon chemi-con KXJ series, 150µF/200V
- For surface mount (SMT) type add the suffix "S" to the model number. Ex: LANC2405UW8S.
- CAUTION:** This power module is not internally fused. An input line fuse must always be used.

**Due to advances in technology, specifications subject to change without notice.*

CHARACTERISTICS

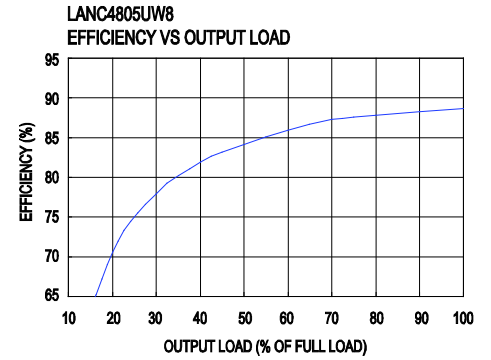
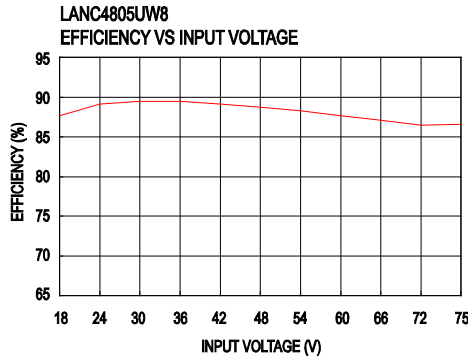
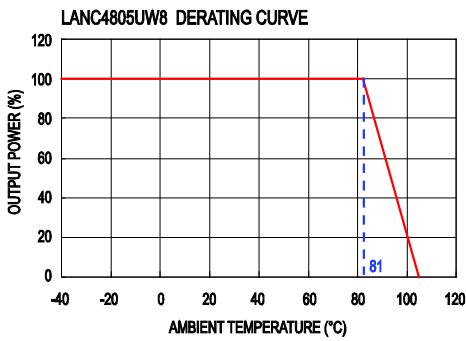

Recommended Filter for EN55022 Class B Compliance

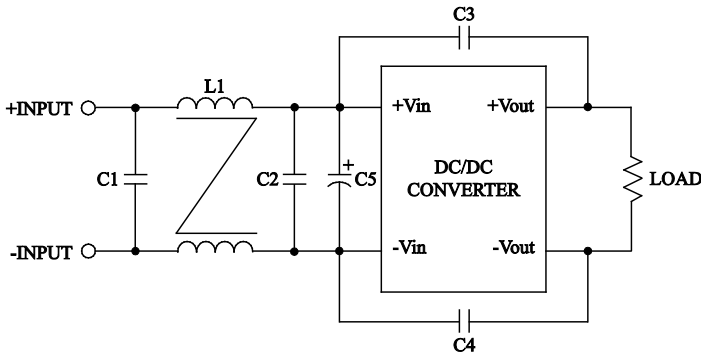

Recommended EN55022 Class B Filter Circuit Layout

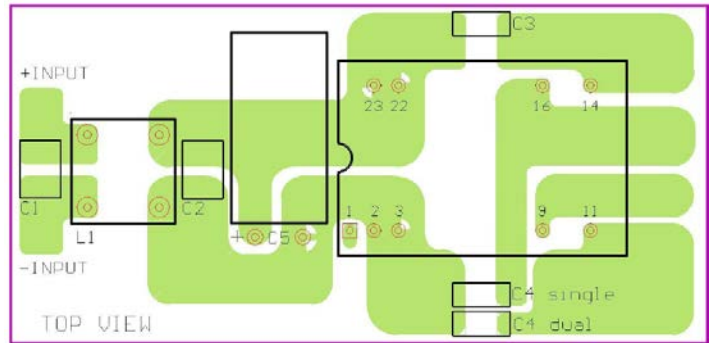

The components used in the figure above are as follows:

MODEL	C1	C2	C3	C4	C5	L1
LANC24xxUW8	4.7µF/50V 1812 MLCC	N/A	1000pF/2KV MLCC	1000pF/2KV MLCC	N/A	325µH Common Choke PMT-050
LANC48xxUW8	1.5µF/100V 1812 MLCC	1.5µF/100V 1812 MLCC	1000pF/2KV MLCC	1000pF/2KV MLCC	N/A	325µH Common Choke PMT-050
LANC110xxUW8	1µF/250V 1812 MLCC	N/A	1000pF/2KV MLCC	1000pF/2KV MLCC	22µF/200V	325µH Common Choke PMT-050

Common Choke L1

PMT-050
L: 325µH±35% / DCR: 35mΩ, max.
Test Conditions: 100KHz / 100mV
Recommended Through Hole: Ø0.8mm

PMT-017
L: 497µH±25% / DCR: 80mΩ, max.
Test Conditions: 100KHz / 20mV
Recommended Through Hole: Ø0.8mm

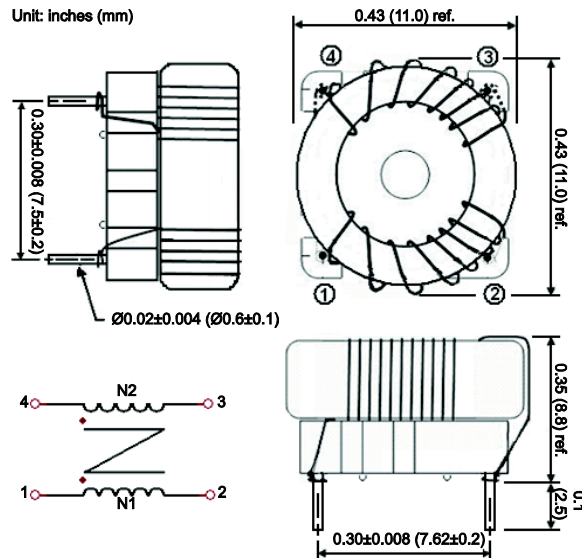

MECHANICAL DRAWING

DIP TYPE

Unit: inches (mm)

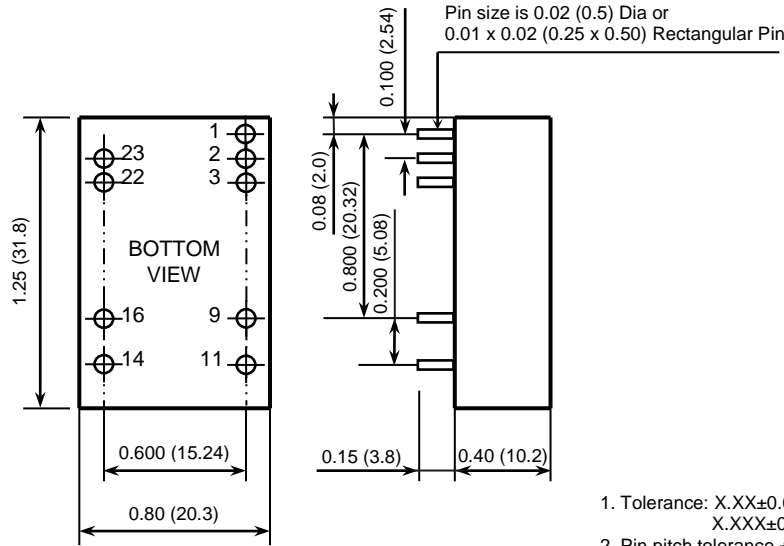

SMT TYPE
 (add Suffix "S")

Unit: inches (mm)

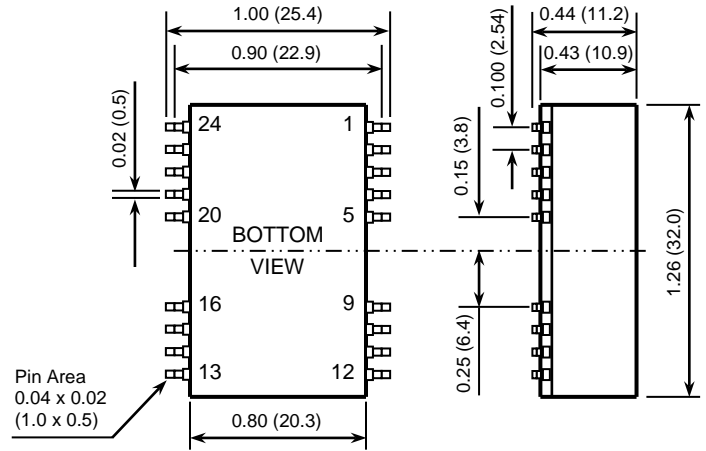

1. Tolerance: X.XX±0.02 (X.X±0.5)
 X.XXX±0.01 (X.XX±0.25)
2. Pin pitch tolerance ±0.01 (0.25)

(DIP) PIN CONNECTION

PIN	SINGLE	DUAL	PIN	SINGLE	DUAL
1	CTRL	CTRL			
2	-INPUT	-INPUT	23	+INPUT	+INPUT
3	-INPUT	-INPUT	22	+INPUT	+INPUT
9	NC	COMMON	16	-OUTPUT	COMMON
11	NC	-OUTPUT	14	+OUTPUT	+OUTPUT

(SMT) PIN CONNECTION

PIN	SINGLE	DUAL	PIN	SINGLE	DUAL
1	CTRL	CTRL			
2	-INPUT	-INPUT	23	+INPUT	+INPUT
3	-INPUT	-INPUT	22	+INPUT	+INPUT
9	NC	COMMON	16	-OUTPUT	COMMON
11	NC	-OUTPUT	14	+OUTPUT	+OUTPUT
Others	NC	NC	Others	NC	NC

COMPANY INFORMATION

Wall Industries, Inc. has created custom and modified units for over 50 years. Our in-house research and development engineers will provide a solution that exceeds your performance requirements on-time and on budget. Our ISO9001-2008 certification is just one example of our commitment to producing a high quality, well-documented product for our customers.

Our past projects demonstrate our commitment to you, our customer. Wall Industries, Inc. has a reputation for working closely with its customers to ensure each solution meets or exceeds form, fit and function requirements. We will continue to provide ongoing support for your project above and beyond the design and production phases. Give us a call today to discuss your future projects.

Contact **Wall Industries** for further information:

Phone: (603)778-2300
Toll Free: (888)587-9255
Fax: (603)778-9797
E-mail: sales@wallindustries.com
Web: www.wallindustries.com
Address: 5 Watson Brook Rd.
 Exeter, NH 03833