

FEATURES

- 5V Supply Voltage
- FOUT Output Period: 40µs(25kHz)
 - RSET = 4.32MΩ
- Fully Assembled and Tested
- 2in x 2in 2-layer circuit board

COMPONENT LIST

DESIGNATION	QTY	DESCRIPTION
C2	1	4.7µF ±10% capacitor (0805)
R1	1	4.32MΩ ± 1% (0805)
U1	1	TS3006
VDD,F_OUT	2	Test points

DESCRIPTION

The TS3006 is a single-supply, second-generation Touchstone Semi oscillator/timer fully specified to operate at a supply voltage range of 1.55V to 5.25V while consuming less than 2.4µA(max) supply current. Requiring only a resistor to set the base output frequency (or output period) at 25kHz (or 40µs) with a 50% duty cycle, the TS3006 timer/oscillator is compact, easy-to-use, and versatile. Optimized for ultra-long life, low frequency, battery-powered/portable applications, TS3006 joins the TS3001, TS3002, TS3004, and TS3005 in Touchstone’s CMOS timer family in its “NanoWatt Analog™” series of high-performance analog integrated circuits.

The TS3006 requires only an RSET = 4.32MΩ resistor to set the FOUT output period to 40µs(25kHz). The complete circuit is designed at a supply voltage of 5V. The TS3006 is fully specified over the -40°C to +85°C temperature range and is available in a low-profile, 8-pin 3x3mm TDFN package with an exposed back-side paddle.

Product datasheet and additional documentation can be found on the factory web site at www.touchstonesemi.com.

ORDERING INFORMATION

Order Number	Description
TS3006DB	TS3006 Demo Board

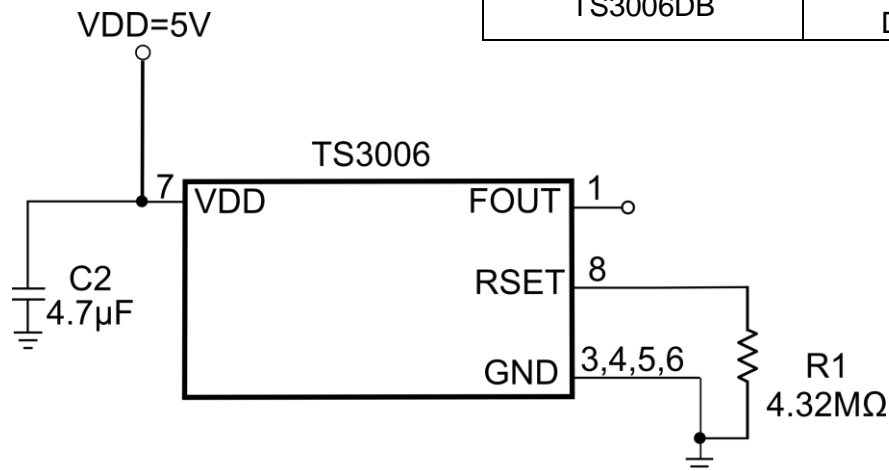

Figure 1. TS3006 Demo Board Circuit

DESCRIPTION

The TS3006 requires only an $R_{SET} = 4.32M\Omega$ resistor to set the FOUT/PWMOUT output period to $40\mu s$ (25kHz). The complete circuit is designed at a supply voltage of 5V and it is shown in Figure 1.

The TS3006 is a user-programmable oscillator where the period of the square wave at its FOUT terminal is generated by an external resistor connected to the RSET pin. The output period is given by:

$$FOUT \text{ (kHz)} = \frac{1.08E11}{RSET}$$

Equation 1. FOUT Frequency Calculation

With $R_{SET} = 4.32M\Omega$, the FOUT period is approximately $40\mu s$ (25kHz) with a 50% duty cycle. As design aids, Table 1 lists TS3006's typical FOUT frequency for various standard values for R_{SET} .

R_{SET} (M Ω)	FOUT (kHz)
0.360	300
1	108
2.49	43.37
4.32	25
6.81	15.86
9.76	11.07
12	9

Table 1: FOUT vs R_{SET}

- 2) Connect the DC power supply positive terminal to the test point labeled VDD. Connect the negative terminal of the DC power supply to the test point labeled GND.
- 3) To monitor the FOUT output signal, connect the signal terminal of an oscilloscope probe to the test point labeled FOUT and the ground terminal to the test point labeled GND.
- 4) Select a channel on the oscilloscope and set the vertical voltage scale and the vertical position to 2V/DIV and 0V, respectively. Set the horizontal time scale to $5\mu s$ /DIV. The coupling should be DC coupling. Turn on the power supply.

The supply current will vary depending on the load on the output. Given the default set-up on the board, the FOUT output period is approximately $40\mu s$. With an output load of 15pF on FOUT due to the oscilloscope probe, the supply current should be less than $4\mu A$.

QUICK START PROCEDURE

Required Equipment

- TS3006 Demo Board
- DC Power Supply
- Oscilloscope Model Agilent DSO1014A or equivalent
- One 10X, 15pF//10M Ω oscilloscope probe

To evaluate the TS3006 silicon timer, the following steps are to be performed:

- 1) Before connecting the DC power supply to the demo board, turn on the power supply, set the DC voltage to 5V, and then turn it off.

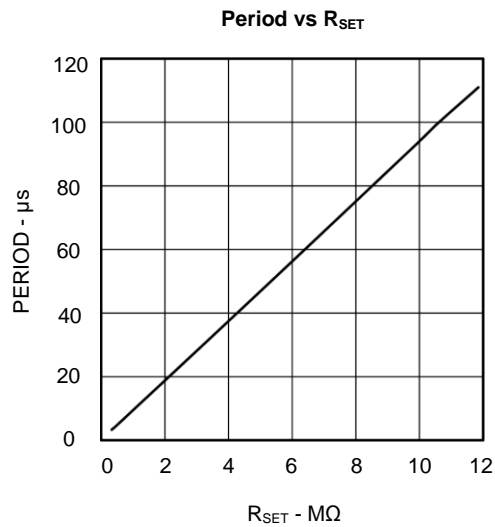

Figure 2. FOUT Period vs R_{SET}

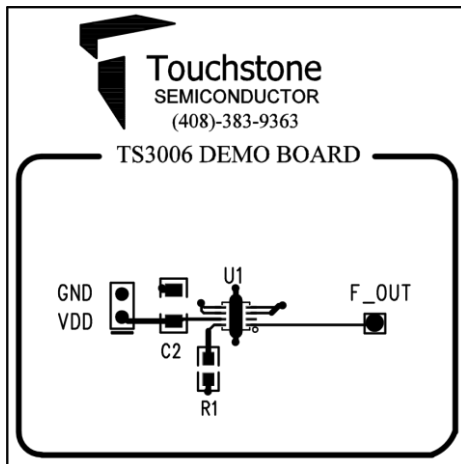

Figure 3. Top Layer View #1

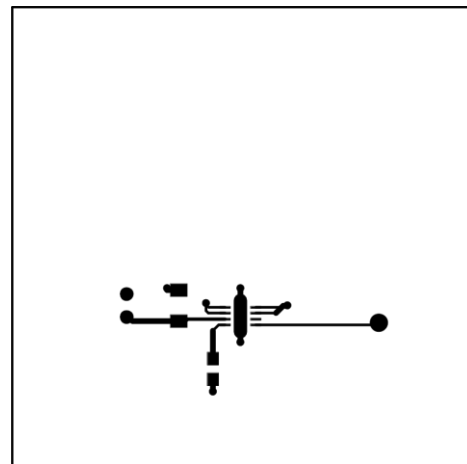

Figure 4. Top Layer View #2

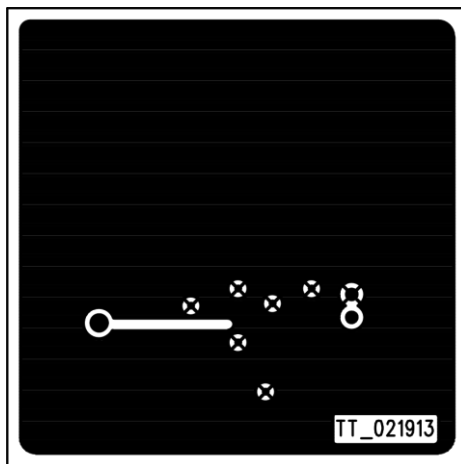

Figure 5. Bottom Layer (GND) #1

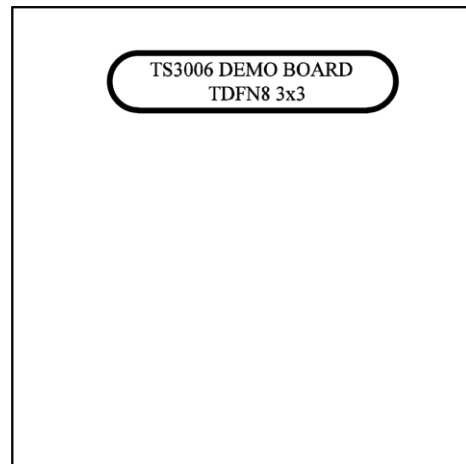

Figure 6. Bottom Layer (GND) #2