

PART NUMBER	SSI-LXH072GD-675	REV.	C
DATE	E.C.N. NUMBER AND REVISION COMMENTS		REV.
01.10.01	E.C.N. #10702.		A
11.02.01	E.C.N. #10807.		B
04.08.11	E.C.N. #10BRDR. & REDRAWN/11686.		C

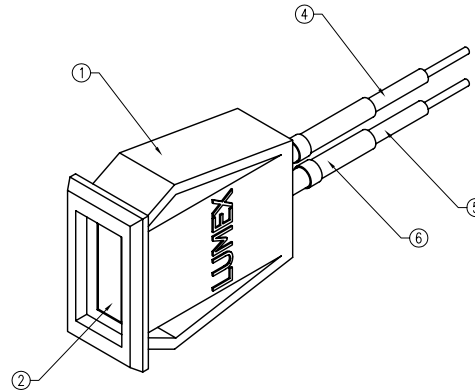
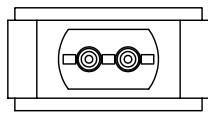
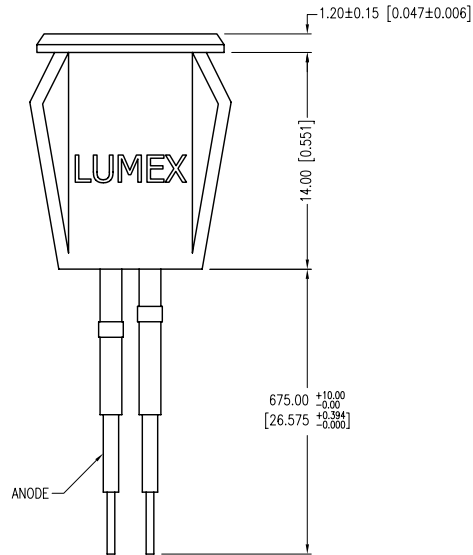
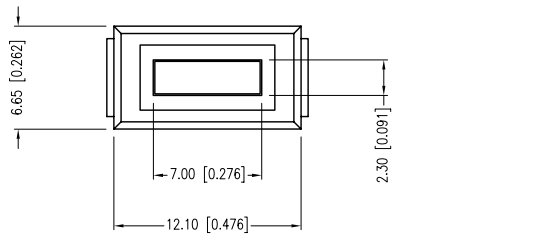

ELECTRO-OPTICAL CHARACTERISTICS $T_A=25^\circ\text{C}$ $I_f=20\text{mA}$					
PARAMETER	MIN	TYP	MAX	UNITS	TEST COND
PEAK WAVELENGTH		565		nm	
FORWARD VOLTAGE		2.2	2.6	V_f	
REVERSE VOLTAGE	5.0			V_r	$I_f=100\mu\text{A}$
AXIAL INTENSITY		9		mcd	$I_f=20\text{mA}$
VIEWING ANGLE		110		2x theta	
EMITTED COLOR:	GREEN				
EPOXY LENS FINISH:	GREEN DIFFUSED				

LIMITS OF SAFE OPERATION AT 25°C		
PARAMETER	MAX	UNITS
PEAK FORWARD CURRENT*	150	mA
STEADY CURRENT	25	mA
POWER DISSIPATION	105	mW
DERATE FROM 25°C	-1.2	mW/°C
OPERATING TEMP.	-40 TO +85	°C
STORAGE TEMP.	-40 TO +85	°C
SOLDERING TEMP.	+260	°C
2.0mm FROM BODY		3 SEC. MAX

* $t < 10\mu\text{s}$

NOTES:

- SSH-LXH072 HOLDER, BLACK.
- SSL-LX25783GD LED, GREEN.
- SECURE LED TO HOLDER WITH GLUE.
- ANODE LEAD: RED 24 AWG, LXP-WST24RDT0C, CUT 660mm, STRIP 3mm & 9.5mm.
- CATHODE LEAD: BLCK 24 AWG, LXP-WST24BLT0C, CUT 660mm, STRIP 3mm & 9.5mm
- HEAT SHRINK TUBING, LXP-HEATSHRINK-2, LENGTH 1.5" TYP. (2 PLS.)
- PANEL CUT OUT SIZE: 5.3mm x 11.0mm.

*UNLESS OTHERWISE SPECIFIED TOLERANCES PER DECIMAL PRECISION ARE: X=±1 (±0.039), X.X=±0.5 (±0.020), X.XX=±0.25 (±0.010), X.XXX=±0.127 (±0.005). LEAD SIZE=±0.05 (±0.002), LEAD LENGTH=±0.75 (±0.030). MIN= $\frac{+DECIMAL}{-0.00}$ PRECISION MAX= $\frac{+0.00}{-DECIMAL}$ PRECISION

LUMEX
 Creating LED and LCD Solutions Together™
 290 E. HELEN ROAD
 PALATINE, IL 60067-6976
 PHONE: +1.847.359.2790
 FAX: +1.847.359.6538
 WEB: WWW.LUMEX.COM

2.3mm x 7mm RECTANGULAR PANEL INDICATOR LED, 565nm GREEN LED, GREEN DIFFUSED, 27" WIRE LEADS.

THE SPECIFICATIONS MAY CHANGE AT ANY TIME WITHOUT NOTICE DUE TO NEW MATERIALS OR PRODUCT IMPROVEMENT.

CONFIDENTIAL INFORMATION
 THE INFORMATION CONTAINED IN THIS DOCUMENT IS THE PROPERTY OF LUMEX INC. EXCEPT AS SPECIFICALLY AUTHORIZED IN WRITING BY LUMEX INC., THE HOLDER OF THIS DOCUMENT SHALL KEEP ALL INFORMATION CONTAINED HEREIN CONFIDENTIAL AND SHALL PROTECT SAME IN WHOLE OR IN PART FROM DISCLOSURE AND DISSEMINATION TO ALL THIRD PARTIES.

DATE:	04.08.11	DRAWN BY:	AB
PAGE:	1 OF 1	CHKD BY:	KF
SCALE:	NTS	APRVD BY:	SS
UNIT:	mm [INCH]		(Pb)