



# Thin-Film Cascadable Amplifier 10 to 2000 MHz

## Technical Data

### UTO/UTC 2026 Series

#### Features

- **Frequency Range: 10 to 2000 MHz**
- **High Output Power: +20.5 dBm (Typ)**
- **Medium Gain: 15.0 dB (Typ)**
- **Temperature Compensated**
- **High Reverse Isolation**

#### Applications

- **IF/RF Amplification**
- **Mixer Driver**

#### Description

The 2026 Series is a two-stage thin-film bipolar RF amplifier using resistive feedback and active bias for temperature compensation and increased immunity to bias voltage variations. Input/output blocking capacitors couple the RF through the amplifier, while a low VSWR is maintained through inductive tuning. The 2026 Series amplifiers are available in either the TO-8 hermetic case or connected TC-1A package.

#### Pin Configuration UTO—TO-8T

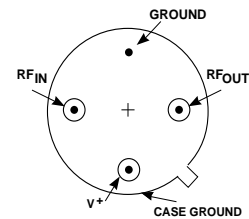

#### UTC—TC-1A

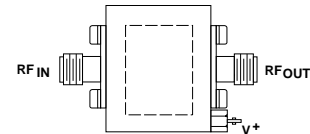

#### Schematic

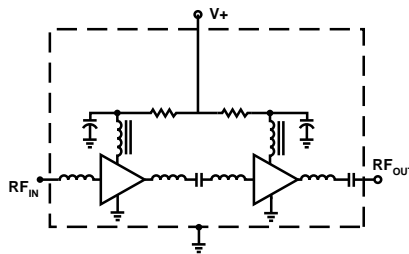

#### Maximum Ratings

Parameter	Maximum
DC Voltage	+17 Volts
Continuous RF Input Power	+13 dBm
Operating Case Temperature	-55 to +115°C
Storage Temperature	-62 to +150°C
“R” Series Burn-In Temperature	+115°C

#### Thermal Characteristics<sup>1</sup>

$\theta_{JC}$	75°C/W
Active Transistor Power Dissipation	459/429/429 mW <sup>2</sup>
Junction Temperature Above Case Temperature	34/32/32°C <sup>2</sup>
MTBF (MIL-HDBK-217E, A <sub>UF</sub> @ 90°C)	356,100 Hrs.

Notes:

1. Values refer to first and second stages, respectively.

**Weight:** (typical) UTO—2.1 grams; UTC—21.5 grams

## Electrical Specifications

(Measured in 50  $\Omega$  system @ +15 VDC nominal unless otherwise noted)

Symbol	Characteristic	Typical $T_C = 25^\circ\text{C}$	Guaranteed Specifications		Unit
			$T_C = 0 \text{ to } 50^\circ\text{C}$	$T_C = -55 \text{ to } +85^\circ\text{C}$	
BW	Frequency Range	10-2000	10-2000	10-2000	MHz
GP	Small Signal Gain (Min.)	15.0	13.5	13.0	dB
—	Gain Flatness (Max.)	$\pm 0.5$	$\pm 1.0$	$\pm 1.5$	dB
NF	Noise Figure (Max.)	6.5	7.0	7.5	dB
P <sub>1dB</sub>	Power Output @ +1 dB Comp. (Min.)	+20.5	+19.0	+18.5	dBm
—	Input VSWR (Max.)	1.6:1	2.0:1	2.0:1	—
—	Output VSWR (Max.)	1.7:1	2.0:1	2.0:1	—
IP <sub>3</sub>	Two Tone 3rd Order Intercept Point	+31.0	—	—	dBm
IP <sub>2</sub>	Two Tone 2nd Order Intercept Point	+45.0	—	—	dBm
HP <sub>2</sub>	One Tone 2nd Harmonic Intercept Point	+51.0	—	—	dBm
I <sub>D</sub>	DC Current	155	—	—	mA

## Typical Performance Over Temperature (@ +15 VDC unless otherwise noted)

Key: +25°C —  
+85°C - -  
-55°C —

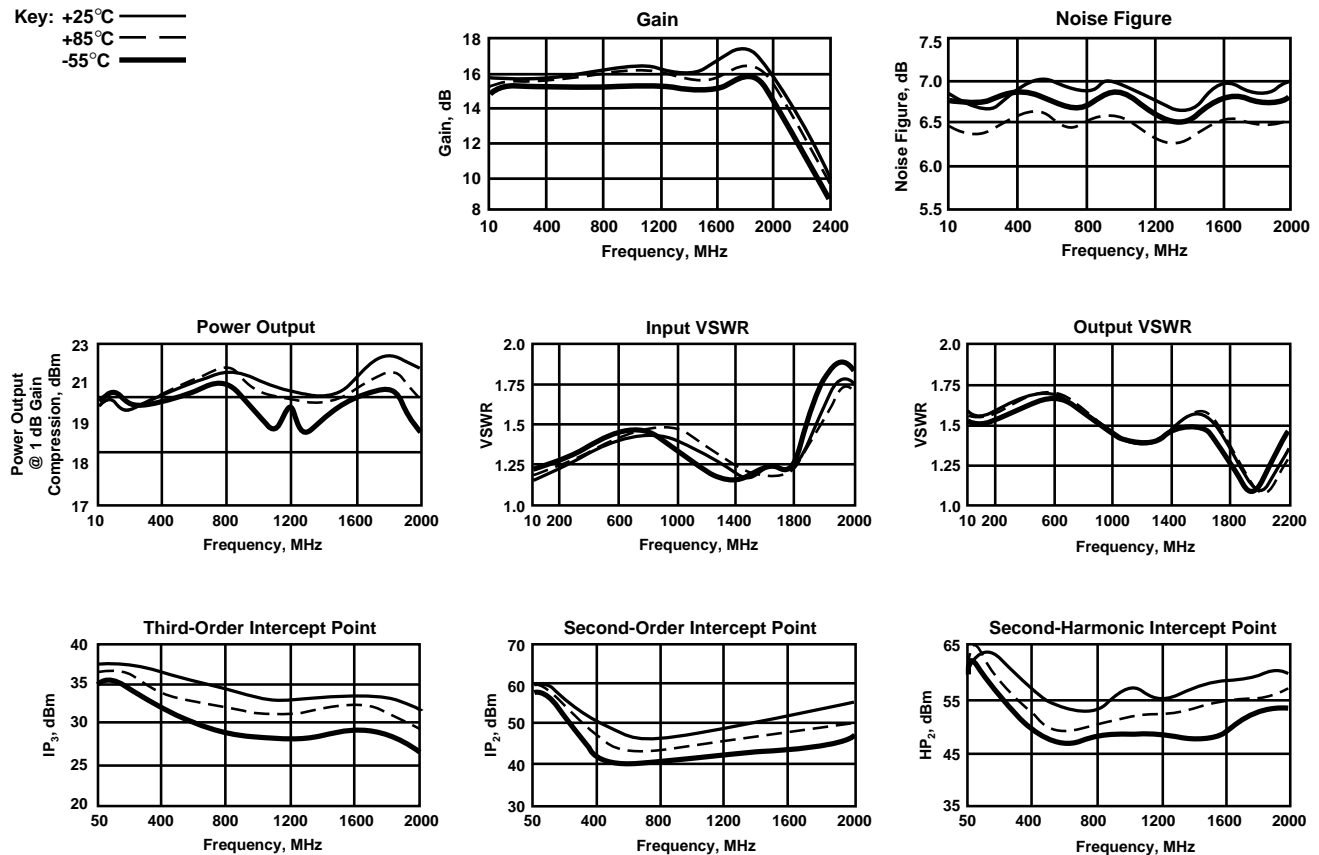

**Automatic Network Analyzer Measurements** (Typical production unit @ +25°C ambient)

**S-Parameters**
**Bias = 15.00 Volts**

FREQ GHz	S <sub>11</sub>		S <sub>21</sub>		S <sub>12</sub>		S <sub>22</sub>		K	GPDEL ns	PHASE DEG
	Mag	Ang	dB	Ang	dB	Ang	Mag	Ang			
.005	.15	-159.0	14.6	39.6	-28.4	36.5	.33	151.85	2.23	12.83	
.010	.09	-170.2	14.9	16.5	-28.1	16.3	.24	162.27	2.23	12.83	9.67
.020	.08	-173.1	14.9	5.5	-28.0	6.7	.22	169.59	2.23	3.03	.87
.050	.09	-172.2	15.0	-5.7	-28.0	-1.4	.21	173.80	2.21	1.04	-4.03
.100	.09	-167.3	15.0	-17.6	-28.0	-8.2	.21	174.87	2.20	.66	-5.36
.150	.09	-163.3	15.0	-28.2	-28.0	-13.6	.21	174.56	2.20	.59	-5.42
.200	.10	-160.7	15.0	-38.5	-28.0	-18.7	.22	173.34	2.21	.57	-5.14
.250	.11	-159.4	15.0	-48.6	-28.1	-23.8	.22	171.33	2.23	.56	-4.63
.300	.12	-159.7	15.0	-58.6	-28.2	-28.9	.23	168.63	2.24	.55	-4.04
.350	.13	-161.0	15.0	-68.5	-28.3	-33.5	.24	165.33	2.25	.55	-3.38
.400	.14	-162.6	15.0	-78.3	-28.4	-38.3	.24	161.41	2.27	.55	-2.68
.450	.15	-164.9	15.0	-88.2	-28.5	-42.7	.25	157.34	2.28	.55	-1.98
.500	.15	-167.4	15.1	-98.0	-28.6	-47.5	.25	152.61	2.29	.55	-1.25
.550	.16	-170.3	15.1	-108.0	-28.6	-52.0	.25	147.22	2.29	.56	-.66
.600	.17	-173.3	15.1	-118.0	-28.7	-56.7	.26	141.36	2.31	.55	-.04
.650	.17	-176.3	15.2	-127.9	-28.8	-61.2	.25	135.06	2.32	.55	.57
.700	.17	-179.2	15.2	-138.0	-28.9	-65.7	.25	128.12	2.34	.56	1.00
.750	.17	178.0	15.2	-148.1	-29.0	-70.0	.24	120.83	2.36	.56	1.57
.800	.17	175.3	15.3	-158.1	-29.1	-74.7	.23	112.98	2.39	.56	2.09
.850	.17	172.7	15.3	-168.4	-29.1	-79.1	.22	104.19	2.41	.57	2.41
.900	.17	170.2	15.3	-178.7	-29.3	-83.6	.21	94.87	2.45	.57	2.70
.950	.17	167.8	15.3	171.1	-29.4	-88.0	.20	84.60	2.48	.57	3.01
1.000	.16	165.6	15.4	160.7	-29.4	-92.5	.19	73.05	2.50	.58	3.15
1.050	.16	163.4	15.4	150.3	-29.6	-97.1	.18	60.38	2.54	.58	3.35
1.100	.15	161.3	15.4	139.8	-29.7	-101.3	.17	46.63	2.59	.58	3.43
1.150	.15	159.2	15.4	129.3	-29.7	-105.5	.16	31.82	2.61	.58	3.48
1.200	.14	157.6	15.4	118.6	-29.9	-110.0	.16	16.17	2.64	.59	3.39
1.250	.13	156.3	15.4	107.9	-29.9	-113.9	.16	.08	2.67	.60	3.28
1.300	.12	155.7	15.4	97.3	-30.0	-118.6	.17	-15.42	2.70	.59	3.22
1.350	.11	156.6	15.3	86.6	-30.0	-122.6	.18	-30.11	2.72	.60	3.10
1.400	.09	160.2	15.2	76.0	-30.0	-126.8	.19	-44.32	2.73	.59	3.06
1.450	.08	167.6	15.2	65.4	-29.9	-131.4	.20	-57.88	2.72	.59	3.09
1.500	.08	178.7	15.1	55.0	-29.9	-135.8	.21	-70.34	2.73	.58	3.25
1.550	.08	-170.5	15.1	44.9	-29.7	-141.0	.22	-82.87	2.67	.56	3.70
1.600	.09	-164.2	15.1	34.8	-29.7	-146.8	.22	-95.19	2.63	.56	4.13
1.650	.10	-161.2	15.2	24.5	-29.6	-153.1	.21	-106.67	2.57	.57	4.38
1.700	.10	-157.9	15.5	13.3	-29.6	-159.5	.21	-117.92	2.52	.62	3.81
1.750	.10	-151.7	15.7	1.3	-29.6	-166.4	.19	-126.77	2.48	.67	2.35
1.800	.11	-142.4	15.9	-11.8	-29.8	-173.3	.17	-138.59	2.49	.73	-.19
1.850	.13	-133.7	15.9	-25.8	-30.0	179.1	.14	-147.28	2.52	.78	-3.62
1.900	.16	-129.9	15.8	-40.4	-30.3	171.8	.11	-153.61	2.63	.81	-7.63
1.950	.19	-130.5	15.6	-55.3	-30.0	164.7	.08	-152.97	2.82	.83	-11.95
2.000	.22	-134.1	15.2	-70.1	-31.4	158.6	.05	-135.66	3.11	.82	-16.15
2.050	.25	-138.8	14.6	-84.5	-31.9	152.3	.06	-100.99	3.46	.80	
2.100	.27	-143.7	13.9	-98.4	-32.6	147.0	.08	-83.99	4.00	.77	
2.150	.28	-148.1	13.2	-111.8	-33.3	143.5	.11	-81.10	4.71	.73	
2.200	.28	-151.6	12.3	-124.1	-33.8	140.1	.15	-83.09	5.43	.70	
2.250	.27	-153.9	11.5	-135.9	-34.5	138.6	.18	-86.55	6.39	.65	
2.300	.27	-154.9	10.6	-147.0	-35.0	137.4	.21	-89.98	7.47	.62	
2.350	.26	-154.0	9.8	-157.7	-35.2	137.4	.23	-93.30	8.23	.60	
2.400	.25	-150.7	9.0	-168.2	-34.9	136.6	.26	-96.82	8.67	.59	
2.450	.25	-145.7	8.3	-178.8	-34.7	133.6	.29	-100.30	9.10	.59	
2.500	.27	-140.1	7.5	170.7	-34.6	130.6	.31	-103.70	9.51	.59	
2.750	.46	-135.7	3.3	119.1	-34.0	101.7	.41	-117.10	11.31	.57	
3.000	.65	-151.3	-1.5	74.3	-34.7	71.1	.45	-124.62	14.87	.50	

LINEARIZATION RANGE: .010 to 2.00 GHz

## Product Options

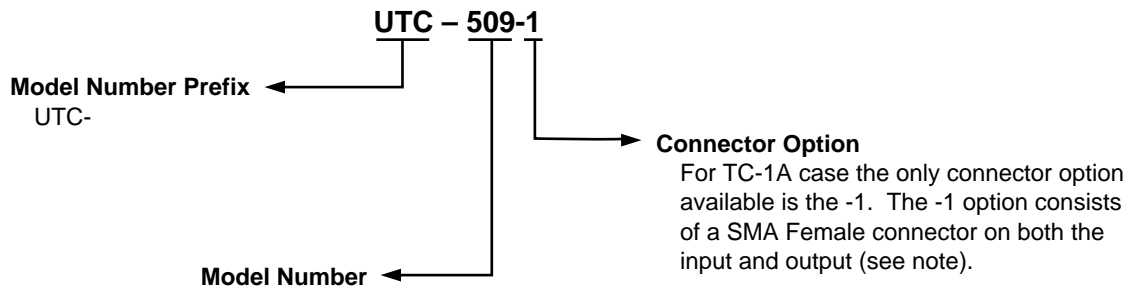
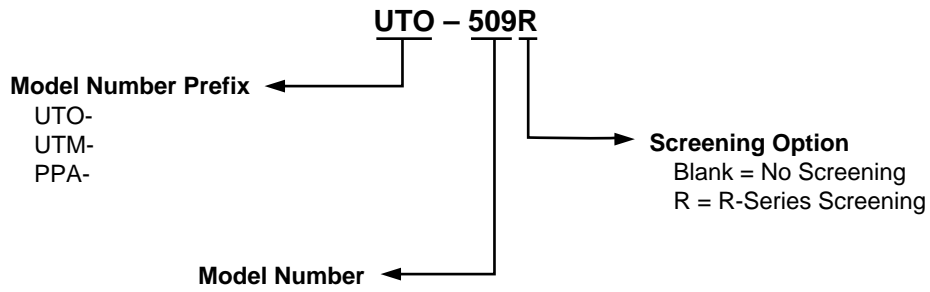

Note: R-Series screening is not available in the TC-1A case as the case is non-hermetic.

## Case Drawings TO-8T

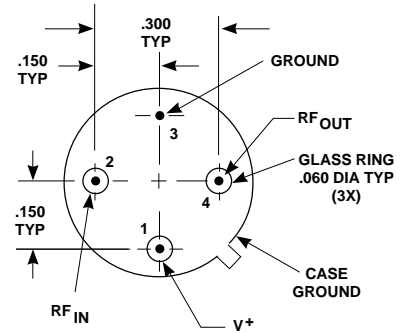
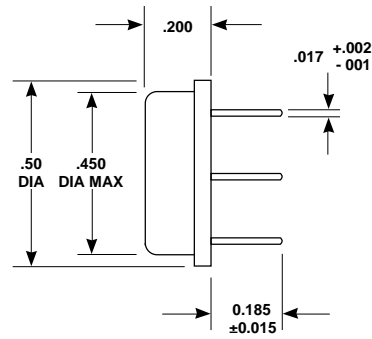
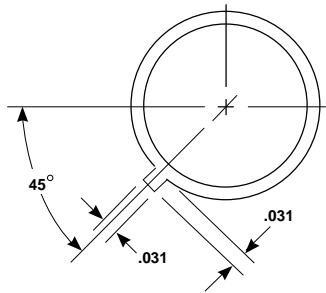

APPROXIMATE WEIGHT 2.1 GRAMS

- NOTES (UNLESS OTHERWISE SPECIFIED):
1. DIMENSIONS ARE SPECIFIED IN INCHES
  2. TOLERANCES:   xx  $\pm$  .02  
                  xxx  $\pm$  .010

**Case Drawings  
TC-1A**

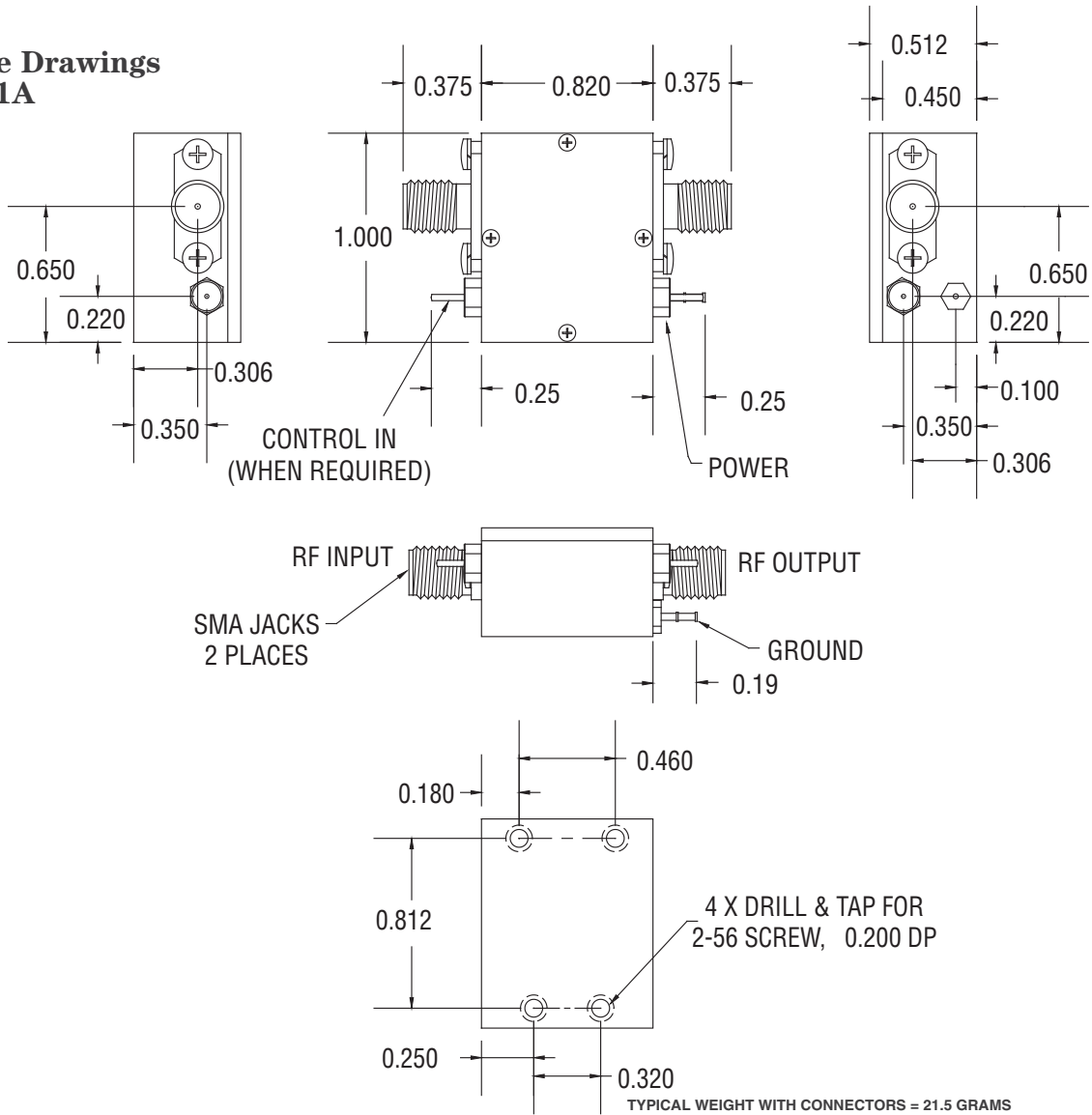

NOTES: 1. THE TC-1A CASE IS A NON-HERMETIC CASE.  
2. THE ONLY CONNECTOR OPTION AVAILABLE FOR THE TC-1A CASE IS THE -1, SMA FEMALE CONNECTORS AT BOTH INPUT AND OUTPUT PORTS.

NOTES (UNLESS OTHERWISE SPECIFIED):  
1. DIMENSIONS ARE SPECIFIED IN INCHES  
2. TOLERANCES: xx ± .02  
xxx ± .010

Contact Teledyne Microwave Solutions:  
650-691-9800  
650-962-6845 fax

Check for updates:  
[www.teledynemicrowave.com](http://www.teledynemicrowave.com)