

SOP8 Plastic-Encapsulate MOSFETS

CJQ4828 Dual N-Channel MOSFET

DESCRIPTION

The CJQ4828 uses advanced trench technology to provide excellent $R_{DS(ON)}$ and low gate charge. This device is suitable for use as a load switch or in PWM applications.

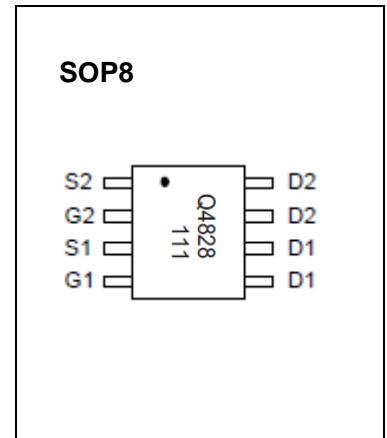
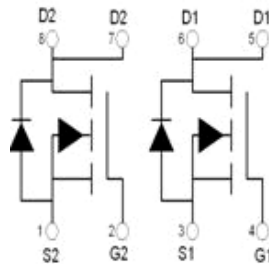

Maximum ratings ($T_a=25^{\circ}C$ unless otherwise noted)

Parameter	Symbol	Value	Units
Drain-Source Voltage	V_{DS}	60	V
Gate-Source Voltage	V_{GS}	± 20	V
Continuous Drain Current ($t \leq 10s$) (note 1)	I_D	4.5	A
Pulsed Drain Current (note 2)	I_{DM}	20	A
Power Dissipation	P_D	1.25	W
Thermal Resistance from Junction to Ambient ($t \leq 10s$) (note 1)	$R_{\theta JA}$	100	$^{\circ}C/W$
Avalanche Current (note 2)	I_{AR}, I_{AS}	19	A
Repetitive Avalanche Energy 0.1mH (note 2)	E_{AR}, E_{AS}	18	mJ
Junction Temperature	T_J	150	$^{\circ}C$
Storage Temperature	T_{STG}	-55~ 150	$^{\circ}C$

Electrical characteristics (T_a=25°C unless otherwise noted)

Parameter	Symbol	Test Condition	Min	Typ	Max	Unit
STATIC PARAMETERS						
Drain-source breakdown voltage	V _{(BR)DSS}	V _{GS} = 0V, I _D = 250μA	60			V
Zero gate voltage drain current	I _{DSS}	V _{DS} = 60V, V _{GS} = 0V			1	μA
Gate-body leakage current	I _{GSS}	V _{GS} = ±20V, V _{DS} = 0V			±100	nA
Gate threshold voltage (note 3)	V _{GS(th)}	V _{DS} = V _{GS} , I _D = 250μA	1		3	V
Drain-source on-resistance (note 3)	R _{DS(on)}	V _{GS} = 10V, I _D = 4.5A			56	mΩ
		V _{GS} = 4.5V, I _D = 3A			77	mΩ
Forward tranconductance (note 3)	g _{FS}	V _{DS} = 5V, I _D = 4.5A	6			S
Diode forward voltage (note 3)	V _{SD}	I _S = 1A, V _{GS} = 0V			1	V
DYNAMIC PARAMETERS (note 4)						
Input Capacitance	C _{iss}	V _{DS} = 30V, V _{GS} = 0V, f = 1MHz			540	pF
Output Capacitance	C _{oss}			60		pF
Reverse Transfer Capacitance	C _{rss}			25		pF
SWITCHING PARAMETERS (note 4)						
Turn-on delay time	t _{d(on)}	V _{GS} = 10V, V _{DS} = 30V, R _L = 6.7Ω, R _{GEN} = 3Ω		4.7		ns
Turn-on rise time	t _r			2.3		ns
Turn-off delay time	t _{d(off)}			15.7		ns
Turn-off fall time	t _f			1.9		ns
Total Gate Charge (10V)	Q _g	V _{DS} = 30V, V _{GS} = 10V, I _D = 4.5A			10.5	nC
Total Gate Charge (4.5V)					5.5	nC
Gate-Source Charge	Q _{gs}			1.6		nC
Gate-Drain Charge	Q _{gd}			2.2		nC

Notes :

1. The value in any given application depends on the user's specific board design.
2. Repetitive rating : Pulse width limited by junction temperature.
3. Pulse Test : Pulse Width ≤ 300μs, Duty Cycle ≤ 0.5%.
4. These parameters have no way to verify.

