

isc N-Channel MOSFET Transistor

2SK1443

DESCRIPTION

- Drain Current $-I_D=1A @ T_C=25^\circ C$
- Drain Source Voltage-
: $V_{DSS}= 450V(\text{Min})$
- Fast Switching Speed

APPLICATIONS

- Designed for high voltage, high speed power switching

ABSOLUTE MAXIMUM RATINGS($T_a=25^\circ C$)

SYMBOL	ARAMETER	VALUE	UNIT
V_{DSS}	Drain-Source Voltage ($V_{GS}=0$)	450	V
V_{GS}	Gate-Source Voltage	± 30	V
I_D	Drain Current-continuous@ $TC=25^\circ C$	1	A
P_{tot}	Total Dissipation@ $TC=25^\circ C$	20	W
T_j	Max. Operating Junction Temperature	150	$^\circ C$
T_{stg}	Storage Temperature Range	-55~150	$^\circ C$

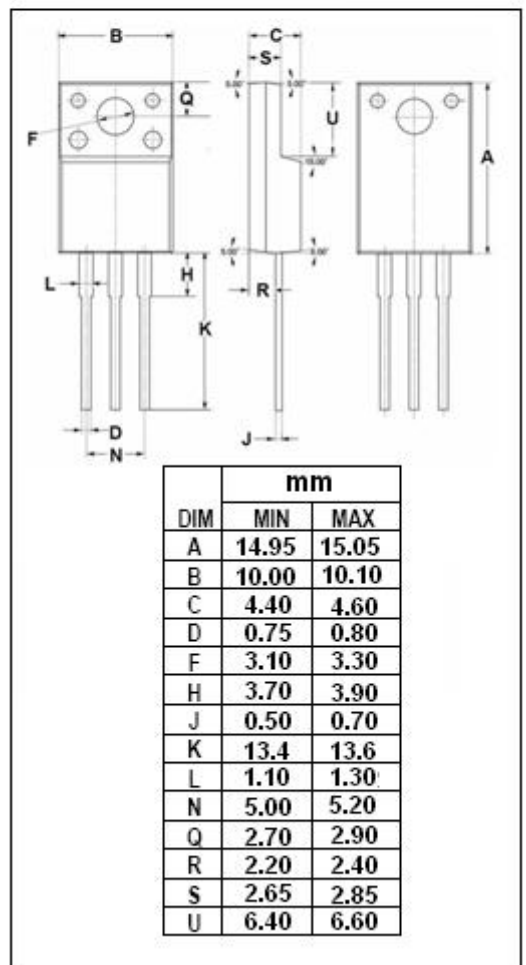
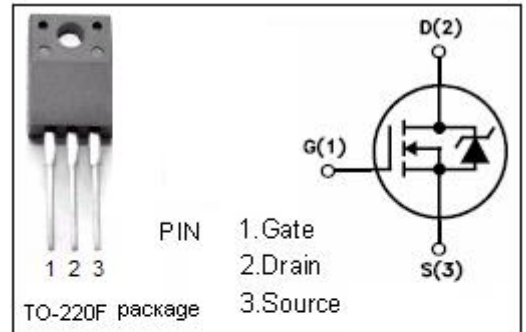

isc N-Channel Mosfet Transistor

2SK1443

• ELECTRICAL CHARACTERISTICS ($T_C=25^\circ\text{C}$)

SYMBOL	PARAMETER	CONDITIONS	MIN	TYP	MAX	UNIT
$V_{(BR)DSS}$	Drain-Source Breakdown Voltage	$V_{GS}=0; I_D=1\text{mA}$	450			V
$V_{GS(th)}$	Gate Threshold Voltage	$V_{DS}=10 V_{GS}; I_D=1\text{mA}$	2.0		3.0	V
$R_{DS(on)}$	Drain-Source On-stage Resistance	$V_{GS}=10\text{V}; I_D=0.5\text{A}$		3.5	4.5	Ω
I_{GSS}	Gate Source Leakage Current	$V_{GS}= \pm 30\text{V}; V_{DS}= 0$			± 100	nA
I_{DSS}	Zero Gate Voltage Drain Current	$V_{DS}=450\text{V}; V_{GS}= 0$			1	mA
V_{SD}	Diode Forward Voltage	$I_F=1\text{A}; V_{GS}=0$			1.8	V
t_r	Rise time	$V_{GS}=10\text{V}; I_D=0.5\text{A}; R_L=50\ \Omega$		9		ns
t_{on}	Turn-on time			19		ns
t_f	Fall time			45		ns
t_{off}	Turn-off time			90		ns