

STDA31 SERIES



30W Desktop Power Supply for I.T. Equipment

- Wide Input Voltage 90 to 264 VAC, 47 to 63Hz
- IEC-320-C14 Inlet
- Output Voltage Available From 5VDC Thru 50VDC
- Single Output
- Input Surge Current, and Over Current Protection.
- CEC Level V, and Energy Star 2.0 Compliance
- Class I Insulation

2 Year Warranty

Approvals: UL US CE PS TUV GS CBC ENEC V ENERGY STAR ROHS

Single Output

Model Number	Output Voltage	Max. Output Current	Load Regulation *	Maximum Output Power
STDA31-S02	5 ~ 6 VDC	4.00 ~ 3.33 A	5%	20W
STDA31-S03	6 ~ 8 VDC	4.16 ~ 3.12 A	5%	25W
STDA31-S04	8 ~ 11 VDC	3.75 ~ 2.72 A	5%	30W
STDA31-S05	11 ~ 13 VDC	2.72 ~ 2.30 A	5%	30W
STDA31-S06	13 ~ 16 VDC	2.30 ~ 1.87 A	5%	30W
STDA31-S07	16 ~ 21 VDC	1.87 ~ 1.42 A	3%	30W
STDA31-S08	21 ~ 27 VDC	1.42 ~ 1.11 A	3%	30W
STDA31-S09	27 ~ 33 VDC	1.11 ~ 0.90A	3%	30W
STDA31-S10	33 ~ 40 VDC	0.90 ~ 0.75A	3%	30W
STDA31-S11	40 ~ 50 VDC	0.75 ~ 0.60A	3%	30W

The output voltage under 15V had been approved by TUV/PSE.

The model number of S04~S11 had been approved by CEC Level V.

The model number of S06 had been approved by KC.

The total regulation on model S01~S05 is required to use AWG#16 / 4FT output cable.

The total regulation on model S06~S08 is required to use AWG#18 / 4FT output cable.

The total regulation on model S09~S11 is required to use AWG#18 / 6FT output cable.

The regulation will be changed by modified output cable.

Electrical Characteristics

Parameter	Test Conditions	Min.	Typ.	Max.	Unit
Input Voltage	Operating Voltage	90		264	VAC
Input Frequency		47		63	Hz
Output Power Range	Vin=90 to 264VAC	0		30	W
Input Current (Low Line)	Io=Full load, Vin=115VAC			0.8	A
Input Current (High Line)	Io=Full load, Vin=230VAC			0.5	A
Low Line Inrush Current	Io=Full load, 25°C Cool start, Vin=115VAC		26	30	A
High Line Inrush Current	Io=Full load, 25°C Cool start, Vin=230VAC		38	45	A
Efficiency	Io=Full Load, Vin=230VAC	73	81	90	%
No-Load Power Consumption	No load, Vin=240VAC	0	0.3	0.5	W
Line Regulation	Io=Full Load		0.5	1	%
Load Regulation	Vin=230VAC		3	7	%
Over Current Protection		110		150	%
Transient Response	Io=Full Load to Half Load, Vin=100VAC			4	mS
Hold-Up Time	Io=Full Load, Vin=110VAC	12			mS
Start Up Time	Io=Full Load, Vin=100VAC	0.3	1	2	S
Ripple & Noise(Peak to Peak)	Full Load, Vin=90VAC		0.5	1	%
Safety Ground Leadage Current	Io=Full Load, Vin=240VAC		0.5	0.75	mA
Temperature Coefficient	All output	-0.04		0.04	%/°C
No-Load Power Consumption	No load, Vin=240VAC	0	0.3	0.5	W

Conditions

Parameter	Test Conditions	Min.	Typ.	Max.	Unit
Operating Temperature		-20	40	70	°C
Storage Temperature		-40		85	°C
Relative Humidity	No-Condensing	5		95	%
Operating Temperature at 25°C, Calculated per MIL-HDBK-217F		0.1M			Hrs
De-rate linearly from 100 % load at 40°C to 50 % load at 70°C					

Approvals and Compliance

Parameter	Test Conditions	Min.	Unit
Dielectric Withstanding Voltage for Primary to secondary	Primary to secondary	4242	VDC
Dielectric Withstanding Voltage for Primary to Ground	Primary to ground	2121	VDC
Isolation Resistance	Test Voltage=500VDC	50	M
Meet EMI requirements: CISPR-22	Vin=220VAC	B	CLASS
Meet EMI requirements: FCC Part15	Vin=110VAC	B	CLASS

Mechanical and PIN out

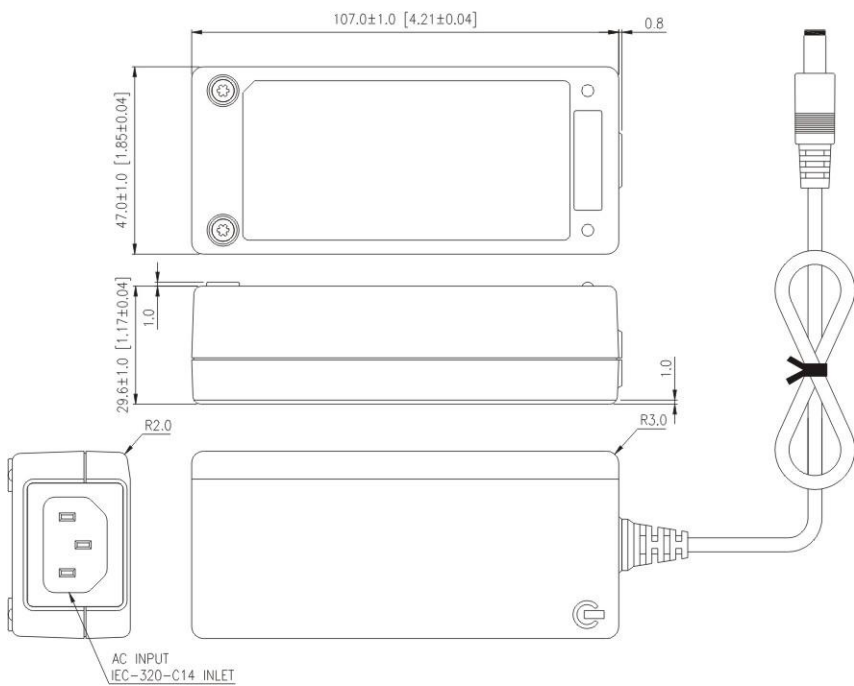

Note:

1. Dimensions are shown in mm & inch
2. Weight: approx. 265-280g
3. Optional output connector.