

# WC415 Series Crystal



- Ceramic SMD Tuning Fork Crystal
- 32.768KHZ
- RoHS Compliant
- Tape and Reel Packaging Available



|                              |  |
|------------------------------|--|
| Frequency                    | 32.768KHZ  |
| Frequency Tolerance at +25°C | ±20 ppm  |
| Load Capacitance             | 12.5pF   |
| Operating Temperature        | -40°C to +85°C   |
| Storage Temperature          | -55°C to +125°C  |
| Turnover Temperature         | +25°C ±5°C   |
| Stability                    | -0.035 ppm / (change in °C) <sup>2</sup> max parabolic curve |
| Equivalent Series Resistance | 70k Ohms Max   |
| Drive Level                  | 1uW max  |
| Aging                        | ±3 ppm first year  |
| Quality Factor               | 30000 typ  |
| Shunt Capacitance            | 1.05pF Max   |

## Part Number Guide

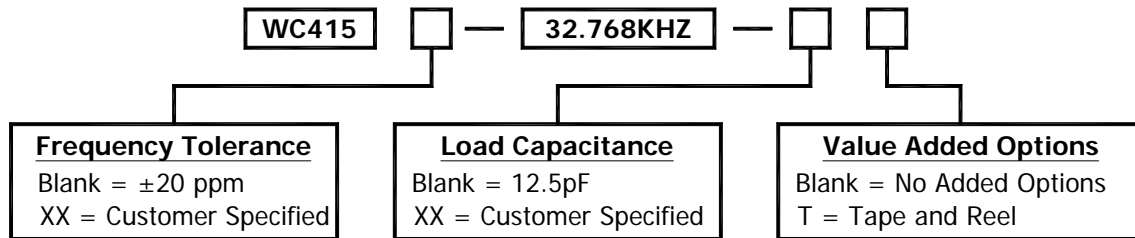

Please consult with MMD sales department for any other parameters or options.



**MMD Monitor/Quartztek**  
 30400 Esperanza, Rancho Santa Margarita, CA, 92688  
 Phone: (949) 709-5075, Fax: (949) 709-3536, [www.mmdcomp.com](http://www.mmdcomp.com)  
 Sales@mmdcomp.com



|           |            |
|-----------|------------|
| Revision: | 11/08/10 D |
|-----------|------------|

## Mechanical Details

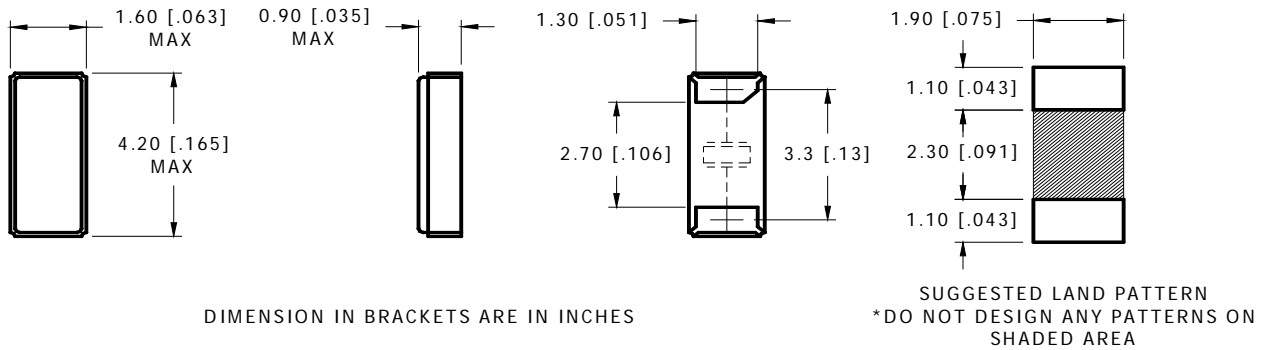

## Tape & Reel

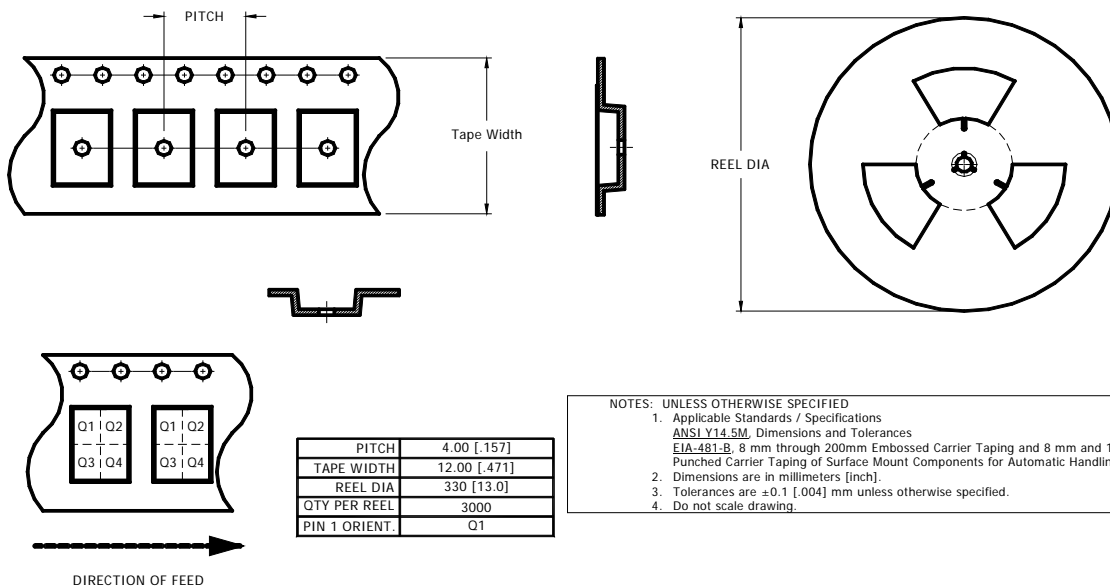

**MMD Monitor/Quartztek**  
 30400 Esperanza, Rancho Santa Margarita, CA, 92688  
 Phone: (949) 709-5075, Fax: (949) 709-3536, [www.mmdcomp.com](http://www.mmdcomp.com)  
 Sales@mmdcomp.com



Revision: 11/08/10 D