



# AN11041

## SSL21081, SSL21083, and SSL2109 non-dimmable buck converter in low ripple configurations

Rev. 1.3 — 23 October 2012

Application note

### Document information

Info	Content
<b>Keywords</b>	SSL21081, SSL21083, SSL2109, buck converter, down converter, driver, topology, AC/DC, retrofit SSL, LED
<b>Abstract</b>	This document describes how to design a buck converter in low ripple configuration, using the SSL21081, the SSL21083 or the SSL2109 driver platform for non-mains dimmable LED applications. It also illustrates the method of calculating components for such applications.



**Revision history**

<b>Rev</b>	<b>Date</b>	<b>Description</b>
v.1.3	20121023	fourth issue
v.1.2	20110701	third issue
v.1.1	20110512	second issue
v.1	20110504	first issue

**Contact information**

For more information, please visit: <http://www.nxp.com>

For sales office addresses, please send an email to: [salesaddresses@nxp.com](mailto:salesaddresses@nxp.com)

## 1. Introduction

The SSL21081, the SSL21083, and the SSL2109 platforms are specially defined to address the retrofit SSL application market. The platforms are optimized for use in cost-effective, high-efficiency driver solutions for high voltage LED strings or LED modules. The buck converter is one of the most commonly used Switch Mode Power Supply (SMPS) topologies.

This application note discusses the general principles and considerations to be addressed, when designing a buck converter using an IC from the SSL21081, the SSL21083, or the SSL2109 platform. These drivers operate in Boundary Conduction Mode (BCM) using peak current control and valley detection for efficient converter on-off switching.

Further information regarding design tools can either be found on the [www.nxp.com](http://www.nxp.com) product page for the specific SSL21081, SSL21083, or SSL2109 IC or is available through your local sales office.

**Remark:** All voltages unless otherwise specified are in V (DC).

### 1.1 Type number overview

The SSL21081, the SSL21083, and the SSL2109 platforms are available in two packages with each two variants. [Table 1](#) shows the market segment that each variant is intended to be used in.

**Table 1. SSL21081, SSL21083, and SSL2109 type number overview**

Type	Package	Nominal mains (V (AC))	MOSFET characteristics	SWP
SSL21081T	SO8	100 to 120	300 V; 20 Ω	yes
SSL21081AT				no
SSL21083T	SO8	230	600 V; 50 Ω	yes
SSL21083AT				no
SSL2109T	SO8	100 to 230	external	yes
SSL2109AT				no

## 2. Basic theory of operation

Before going into detail about the SSL21081, SSL21083, and SSL2109 applications, it is important to have a basic knowledge of buck converters.

The operation of the buck converter can consist of an inductor and a switch control the inductor input current. It alternates between connecting the inductor to source voltage to store energy in the inductor and discharging the energy into the load.

More detailed information about this principle is given in the general application note “*Buck converter for SSL applications*” (AN10876) (see [Ref. 1](#)).

More detailed information about external MOSFET design considerations are described in the application note “*SSL2109T/AT/SSL2129AT controller for SSL applications*” (AN11136) (see [Ref. 4](#)).

### 3. Functional description

The SSL21081, the SSL21083, and the SSL2109 are Multi-Chip Modules (MCM) available in the SO8 package. The SSL21081 and SSL21083 variants have an integrated switch. The SSL2109 required an external switch. Regardless of the switch, the main difference between the variants, is the maximum voltage of the internal MOSFET switch and SWP. See [Table 1](#) and [Table 2](#) for the specifics of each IC.

The SSL21081, SSL21083, and SSL2109 families of ICs provide the following features:

- Switch-mode buck controller with power-efficient boundary conduction mode of operation with:
  - No reverse recovery losses in freewheel diode
  - Zero Current Switching (ZCS) for turn-on of switch
  - Zero voltage or valley switching for turn-on of switch
  - Minimum inductance value and size for the inductor
- High Power Factor (> 0.9) applicable (SSL2109AT only)
- Direct Pulse-Width Modulation (PWM) dimming possible
- Fast transient response through cycle-by-cycle current control:
  - Prevents overshoots or undershoots in the LED current
- Internal Protective functions:
  - UnderVoltage LockOut protection (UVLO)
  - Leading Edge Blanking (LEB)
  - OverCurrent Protection (OCP)
  - Short Winding Protection (SWP; SSL21081T, SSL21083T, SSL2109T)
  - Internal OverTemperature Protection (OTP)
  - Brownout protection
  - Output short-circuit protection
  - Easy external temperature protection using an NTC resistor

Further details and full specifications can be found in the *SSL21081\_SSL21083 and SSL2109\_SER data sheets* ([Ref. 2](#), [Ref. 3](#)).

**Table 2. Pin description**

Symbol	Pin (SO8)	Description
<b>SSL21081, SSL21083</b>		
HV	1	high-voltage supply pin
SOURCE	2	low-side internal switch
VCC	3	supply voltage
NTC	4	LED temperature protection input
DVDT	5	AC supply pin
GND	6, 7	ground
DRAIN	8	high-side internal switch

Table 2. Pin description ...continued

Symbol	Pin (SO8)	Description
<b>SSL2109</b>		
HV	1	high-voltage supply pin
VCC	2	supply voltage
NTC	3	temperature protection input
SOURCE	4	low-side external switch
DRIVER	5	driver output
DVDT	6	AC supply pin
GND	7	ground
DRAIN	8	high-side external switch

## 4. Step-by-step design procedure

This section provides a step-by-step guide for designing a basic buck converter application using the SSL21081, the SSL21083, or the SSL2109.

**Remark:** The derivation of the equations applied is beyond the scope of this application note. Where values used in formulas are application specific, reasonable estimates have been made.

### 4.1 Basic configuration

A typical buck application in low-ripple configuration for the SSL21081 and SSL21083 platforms, driving a single LED chain, is shown in [Figure 1](#).

The mains voltage is rectified, buffered and filtered in the input section and connected via the LED string through the inductor to the DRAIN pin of the SSL21081 and SSL21083. When the internal MOSFET is switching, the stored energy in L2 modulates the current through the LED chain. During the primary stage ( $\delta 1$ ), the current through the inductor is sensed by R1 and when  $V_{th(ocp)SOURCE}$  is reached on the SOURCE pin, the internal MOSFET is switched off and the secondary stage ( $\delta 2$ ) starts.

The internal MOSFET switch is only switched on when it detects that no current is flowing through the inductor by detecting a valley on the DRAIN pin. This system is called Valley Detection and reduces the switching losses significantly (see [Section 4.4](#)).

Non-dimmable buck converter in low ripple configuration

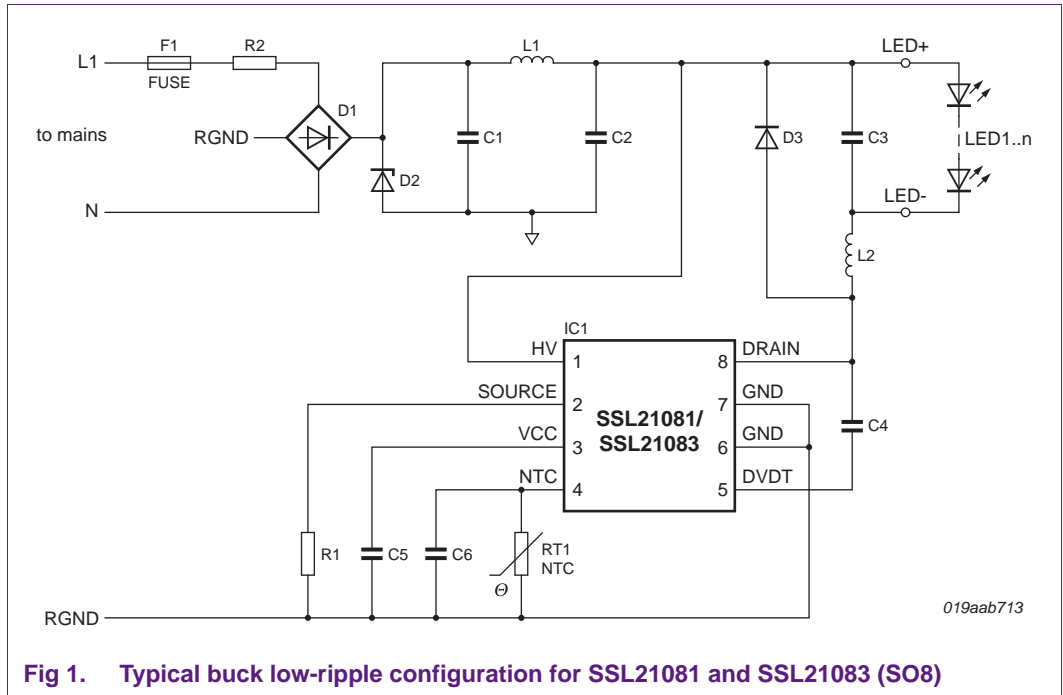

Fig 1. Typical buck low-ripple configuration for SSL21081 and SSL21083 (SO8)

**Remark:** In [Figure 1](#) the LED string is connected above L2. This is to prevent the LEDs having a voltage variation equal to the drain voltage. As the LED assembly is relatively large with extended wires and a heatsink, it has substantial capacitive coupling compared to its surroundings. This capacitive coupling would have a detrimental effect on efficiency and EMC.

The starting parameter, for designing a circuit as shown in [Figure 1](#), is the required LED current ( $I_{LED}$ ) and the LED voltage ( $V_{LED}$ ). Assuming the converter works exactly in boundary conduction mode, the relationship between output current and inductor peak current ( $I_{peak}$ ) is:

$$I_{peak} = 2 \cdot I_{LED} \tag{1}$$

The same inductor is used (L2 in [Figure 1](#)) to charge and discharge energy, so there is a direct dependency between  $\delta 1$  and  $\delta 2$ , the LED forward voltage and input voltage:

$$\frac{(V_i - V_o)}{V_o} = \frac{\delta 2}{\delta 1} = \frac{t_2}{t_1} \tag{2}$$

## 4.2 Input section

The SSL21081, the SSL21083, and the SSL2109 platforms can be configured for an AC mains input voltage of 100 V, 120 V 230 V or for the universal AC mains input voltage range of 90 V to 264 V. Using the universal mains configuration, a compromise must be made with respect to the overall performance. For all applications the input section consists of:

- The rectifying stage
- Protection against overvoltage
- Protection against overcurrent and inrush peak current
- Buffer circuit with EMI filter

### 4.2.1 OverVoltage Protection (OVP)

The AC mains input voltage is rectified with diode bridge D1. The Transient Voltage Suppression (TVS) diode (D2) has been added for overvoltage protection. All components must withstand the voltage at which D2 sets it. The protection level can be calculated by [Equation 3](#):

$$V_{D2} = \sqrt{2} \cdot V_{mains(max)} \cdot \alpha \quad (3)$$

$\alpha = 1.1$  for non-triac dimmable applications.

### 4.2.2 OVP and inrush peak current protection

Primary protection against overcurrent is a fuse or fused resistor that breaks down when the current is too high. If a fuse is selected, a value should be chosen that handles the inrush current whilst still providing protection. In practice, a value of 1 A to 1.5 A is sufficient. If a fused resistor is selected, the minimum value for this resistor, for inrush current protection, can be calculated with [Equation 4](#). Typically, for most diode bridge rectifiers, the  $I_{FSM}$  parameter is about 20 A.

$$R2 = \frac{\sqrt{2} \cdot V_{mains(max)}}{I_{FSM}} \quad (4)$$

For example, at 230 V (AC), +20 %,  $V_{mains(max)}$  is 276 V (AC). The calculated value for R1 is 19.4  $\Omega$  and becomes the practical value of 20  $\Omega$ .

In addition to the ohmic value, the continuous power dissipation is important. This power can be determined based on the power consumption of the complete circuit. [Equation 5](#) can be used:

$$P_{R2} = C \cdot R_2 \cdot \frac{P_{tot}^2}{V_{mains}^2} \quad (5)$$

The crest factor C is the ratio between peak current and average current. In [Figure 1](#), the crest factor is normally around a factor 4.

For example, at 230 V (AC),  $P_{tot} = 15.7$  W,  $R2 = 20$   $\Omega$ , crest-factor = 4, the dissipated power in R2 is 370 mW.

### 4.2.3 Buffer circuit with EMI filter

The buffer with EMI filter circuit is made with two capacitors (C1 and C2) and an inductor (L1). The circuit has a dual functionality:

- To store energy to enable the converter to transfer continuous power to the LED string. LED operation becomes independent of mains power fluctuations as these are filtered out.
- To filter ripple current due to converter operation ensuring compliance with legal standards and regulations for mains conducted emissions.

#### 4.2.3.1 Buffer capacitor calculation (low-ripple configuration only)

The energy absorption of the convertor is regarded as stable (constant power sink) and the intersection of buffer voltage and next mains rising voltage is calculated. The voltage over the converter must not drop below minimum working voltage  $V_{buff(min)}$  within one mains period. This is the level at which the current through coil L2, still reaches  $I_{peak}$  within  $t_{on(max)}$ .

$$V_{buff(min)} = V_o + \left( L2 \cdot \frac{I_{peak}}{t_{on(max)}} \right) \quad (6)$$

Next calculate the time between the mains peak voltage ( $V_{mains(peak)}$ ) and when the mains voltage has reached this minimum voltage. Use a margin of 10 V to allow for voltage drop during capacitor charging (see [Figure 2](#)).

$$t_{dis} = \left( 1 + \frac{2}{\pi} \operatorname{asin} \left( \frac{V_{buff(min)} + 10}{V_{mains(peak)}} \right) \right) \cdot \frac{1}{4 \cdot f_{net}} \quad (7)$$

For example, at a mains voltage 230 V (AC), 50 Hz frequency and minimum operating voltage of 85 V (AC), the time that capacitors take to discharge =  $t_{dis} = 5.94$  ms.

Take total converter power and add IC losses together with system losses. [Equation 8](#) calculates the total value of the buffer capacitance:

$$C1 + C2 = \frac{2 \cdot P_{tot} \cdot t_{dis}}{V_{mains(peak)}^2 - V_{buff(min)}^2} \quad (8)$$

For example, using the previously calculated values, at converter output power of 10 W, with both an IC loss and system loss of 500 mW each, the total capacitance is 1.25  $\mu$ F (i.e.  $C1 = C2 = 680$  nF).



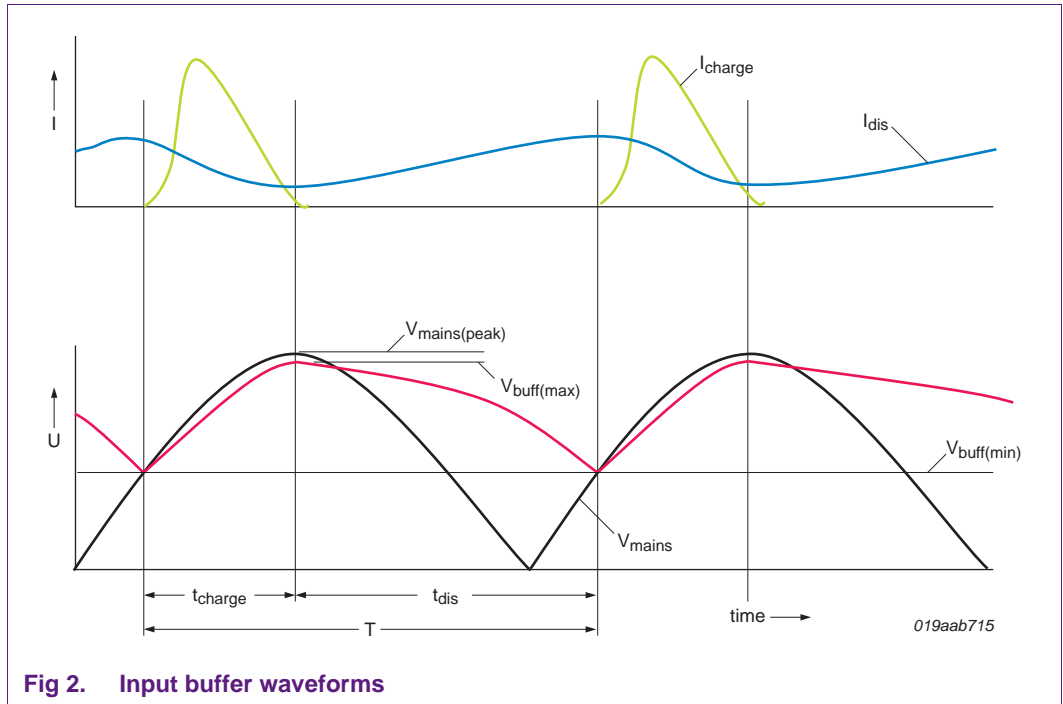

Fig 2. Input buffer waveforms

4.2.3.2 EMI filter

The combination of L1, C1 and C2 creates a pi-filter that helps to filter out the high frequency currents caused by converter operation. Though a single filter stage is often not sufficient to reach the limits defined by the legal regulations, it helps to reach the requirements. The cut-off frequency of this filter is a magnitude below the converter frequency.

$$f_{cutoff} = \frac{1}{2 \cdot \pi \cdot \sqrt{\left( L1 \cdot \frac{C1 \cdot C2}{C1 + C2} \right)}} \tag{9}$$

If the cut-off frequency is selected 10 kHz below the working frequency, the resulting formula for L1 is:

$$L1 = \frac{100}{C_s \cdot 4\pi^2 \cdot f_{sw}^2} \tag{10}$$

For example, when  $C_s = C1 // C2$ . At  $C1 = C2 = 680 \text{ nF}$  and converter frequency of 100 KHz, then L1 becomes 372  $\mu\text{H}$ .

**Remark:** It is recommended to use a low frequency, absorbent soft ferrite material, such as 3S1 (Ferroxcube) or 3W1200 (Würth) for this inductor to dissipate the high frequency energy and block unwanted oscillations.

4.3 Buck converter inductor dimensioning

Since there is a direct relation between total stroke times and converter frequency, the inductor value can be derived easily when the converter frequency is chosen:

$$f_{sw} = \frac{1}{T} \quad (11)$$

$$T = t_1 + t_2 \quad (12)$$

$$I_{peak} = t_1 \cdot \frac{V_i - V_{LED}}{L2} \quad (13)$$

$$V_i = \sqrt{2} \cdot V_{mains} \quad (14)$$

Combining [Equation 1](#), [Equation 2](#), [Equation 10](#), [Equation 11](#), [Equation 12](#) and [Equation 13](#) results in:

$$L2 = \frac{1}{2 \cdot I_{LED} \cdot f_{sw}} \cdot \frac{(V_{LED}^2 - (V_i \cdot V_{LED}))}{V_i} \quad (15)$$

#### 4.4 Valley detection

The next converter cycle (MOSFET switch is switched on) can start just after  $\delta 2$  has ended and the converter current has reached zero. In doing this, the switch switches on again with substantial voltage over it. There is a certain amount of capacitance ( $C_P$ ) on the DRAIN pin which is built-up of several components:

- The parallel capacitance of the inductor
- The reverse charge of the freewheel diode D3
- The drain-gate capacitance of the switch
- The dV/dT capacitor connected to the DVDT pin

When discharging this capacitance, the stored energy is dissipated in the switch:

$$P_{sw} = \frac{1}{2} \cdot C_P \cdot V_{sw}^2 \cdot f_{sw} \quad (16)$$

For example, at  $f = 100$  kHz,  $V_{sw} = 200$  V,  $C_P = 100$  pF then  $P_{sw} = 200$  mW.

As a result, the switch heats up and the efficiency decreases. To overcome this, the valley detect feature has been built-in that is unique for NXP Semiconductors' converters. The valley detect circuitry senses when the voltage on the drain of the switch has reached its lowest value and this is used to trigger the next cycle. As a result, the switching losses are decreased significantly (see [Figure 3](#)).

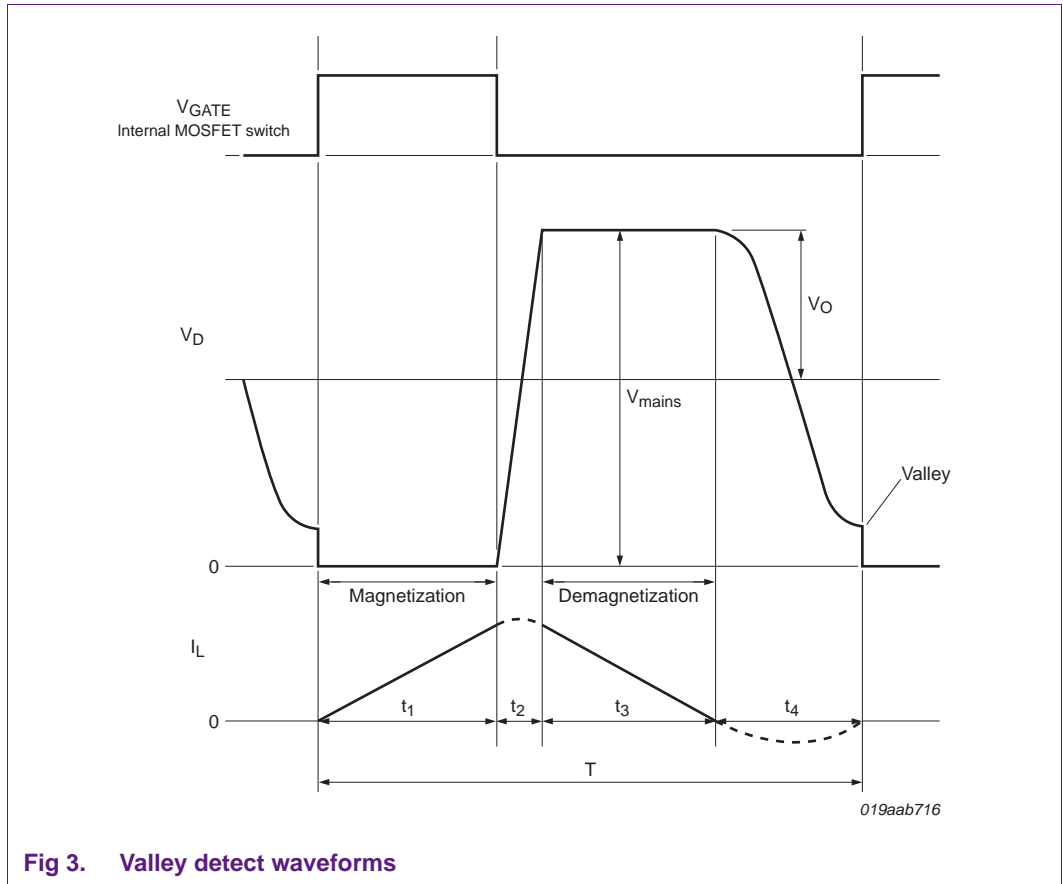

Fig 3. Valley detect waveforms

A time ( $t_4 = t_{valley}$ ) is introduced in which there is a little current on the inductor. This time lasts half the period of the resonant frequency:

$$t_{valley} = \pi \cdot \sqrt{L_P \cdot C_P} \tag{17}$$

For example, at  $L_P = L_2 = 1 \text{ mH}$ ,  $C_P = 300 \text{ pF}$ , then  $t_{valley} = 1.72 \text{ }\mu\text{s}$ .

To be most effective, two conditions must be met:

- The output excitation voltage ( $V_o$ ) must be close to half the input voltage
- The  $L_P C_P$  combination must be under dampened

$$V_o = \frac{1}{2} \cdot V_i \tag{18}$$

and

$$R_{ser}^2 \cdot C_P^2 - 4 \cdot L_P \cdot C_P \ll 0 \tag{19}$$

$R_{ser}$  = the serial dampening resistor within the  $L_P C_P$  circuit and consists of coil resistance and magnetic losses.

For example at  $V_i = 200 \text{ V}$ ,  $V_o = 100 \text{ V}$ ,  $V_o = 0.5 V_i$

and  $R_{ser} = 1$ ,  $C_P = 100 \text{ pF}$ ,  $L_2 = 1 \text{ mH}$  gives  $-4.00 \times 10^{-3} \ll 0$ .

However, to reach the same LED current, the peak value must be adjusted and this in turn alters the converter frequency. The average current  $I_{LED}$  at the output can be calculated with [Equation 10](#), [Equation 11](#), [Equation 12](#) and [Equation 13](#):

$$I_{LED} = \frac{I_{peak} \cdot (t_1 + t_2 + t_3)}{2 \cdot (t_1 + t_2 + t_3 + t_4)} \quad (20)$$

$$\varphi = \frac{V_o}{V_i - V_o} \quad (21)$$

$$t_3 = \frac{I_{peak} \cdot L2}{V_o} \quad (22)$$

$$t_1 = \frac{I_{peak} \cdot L2}{V_i - V_o} \quad (23)$$

Combining [Equation 20](#), [Equation 21](#), [Equation 22](#) and [Equation 23](#) results in [Equation 24](#):

$$2 \cdot I_{LED} = \frac{\frac{I_{peak}^2 \cdot L2}{V_o} \cdot (\varphi + 1)}{\frac{I_{peak} \cdot L2}{V_o} \cdot (\varphi + 1) + t_4} \quad (24)$$

When written out, it results in:

$$0 = L2 \cdot (\varphi + 1) \cdot I_{peak}^2 - 2 \cdot I_{LED} \cdot (\varphi + 1) \cdot L2 \cdot I_{peak} - 2 \cdot I_{LED} \cdot t_4 \cdot V_o \quad (25)$$

This 2<sup>nd</sup> order function can be solved using the ABC formula:

$$a = L2 \cdot (\varphi + 1) \quad (26)$$

$$b = -2 \cdot L2 \cdot (\varphi + 1) \cdot I_{LED} \quad (27)$$

$$c = -2 \cdot t_4 \cdot V_o \cdot I_{LED} \quad (28)$$

$$I_{peak} = \frac{-b \pm \sqrt{b^2 - 4 \cdot a \cdot c}}{2 \cdot a} \quad (29)$$

For example:  $\varphi = 1$ ,  $a = 0.714 \times 10^{-3}$ ,  $b = -1 \times 10^{-3}$ ,  $c = -83.1 \times 10^{-6}$ ,  $I_{peak} = 1.48$  A,  $t_1 = 5.28$   $\mu$ s,  $t_3 = 5.28$   $\mu$ s,  $t_4 = 0.594$   $\mu$ s,  $f = 89.6$  kHz.

When switching from primary to secondary stage (i.e. when the MOSFET is switched off), a high voltage is induced on the DRAIN pin which becomes equal to  $V_i$  (excluding the freewheel diode drop). This fast rising of the DRAIN pin is controlled by the SSL21081, the SSL21083, or the SSL2109 to about 4 V/ns.

## 4.5 SSL21081, SSL21083, and SSL2109 protection circuits

The SSL21081, the SSL21083, and the SSL2109 incorporate the following protection circuits which can be adjusted and therefore calculated:

- Overcurrent protection (OCP)
- NTC External temperature control and protection

### 4.5.1 OverCurrent Protection (OCP)

The SSL21081, the SSL21083, and the SSL2109 operate in boundary conduction mode and when the MOSFET is switched on, the voltage level on the SOURCE pin increases because the inductor current also flows through the external resistor R1 (see [Figure 1](#)). In this schematic, resistor R1 limits the peak current ( $I_{peak}$ ). When the voltage level over this resistor reaches a threshold, the cycle stops and the switch stops conducting. This threshold can be used to control peak current. Using peak current control, the LED current is half the peak current in BCM mode. In addition, the tolerance on this detection is proportional with the tolerance on LED current. The threshold level is  $V_{th(ocp)}$  and [Equation 29](#) can be used:

$$R1 = \frac{V_{th(ocp)}}{I_{peak}} \quad (30)$$

For example,  $I_{peak} = 1.48 \text{ A}$ ,  $V_{th(ocp)} = 0.52 \text{ V}$ ,  $R1 = 0.35 \text{ } \Omega$ .

### 4.5.2 NTC protection and control functions

The multi-functional NTC pin can be used for following functions:

- Output current control for thermal protection
- Soft-start function
- Analog LED light output dimming, from 50 % to 100 %

#### 4.5.2.1 Thermal protection

The pin has an internal current source that generates a current of 47  $\mu\text{A}$ . An NTC resistor can be directly connected to this pin. Depending on the NTC's resistor value, the ambient temperature and the corresponding voltage on pin NTC, the  $V_{th(ocp)SOURCE}$  level is shifted. As result the output current is adjusted to maintain the ambient temperature within the defined range. The output current is controlled as shown in [Figure 4](#).

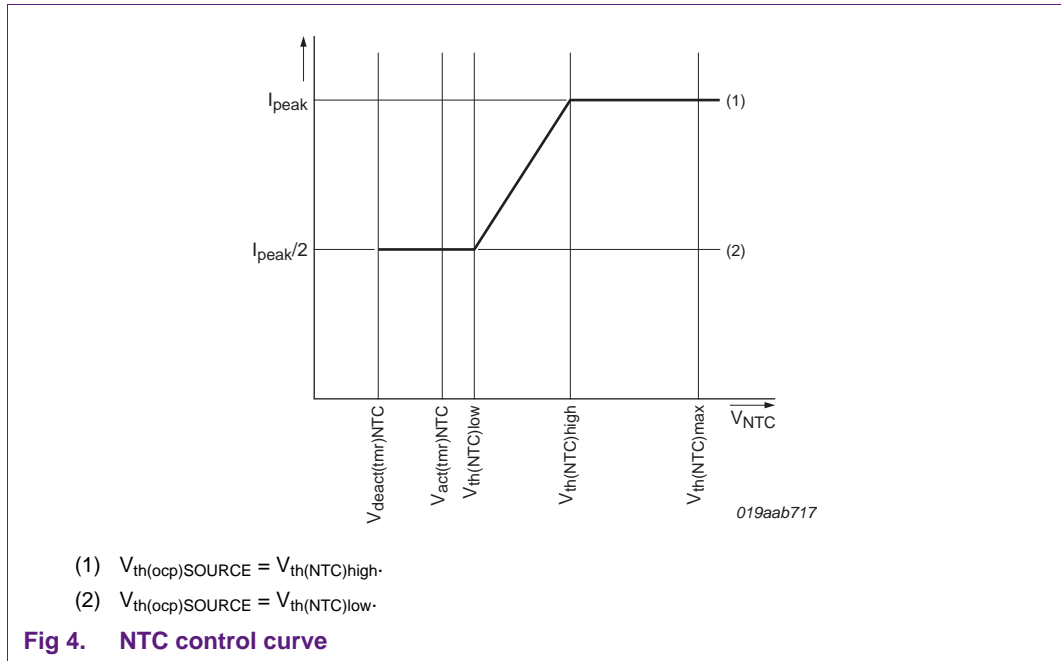

When the voltage on pin NTC is above the high threshold  $V_{th(NTC)high}$ , the converter delivers nominal output current. Below this voltage level, the peak current is gradually reduced until  $V_{th(NTC)low}$ . At this point, the peak current is half the peak current for nominal operation. When the voltage on pin NTC passes  $V_{act(tmr)NTC}$ , a timer starts to run and two situations can be distinguished:

- When the low-level threshold  $V_{deact(tmr)NTC}$  is not reached within 100  $\mu s$ , the IC stops switching and tries to restart from the HV pin voltage. This restart only takes place after the voltage on pin NTC is above  $V_{th(NTC)high}$ . It is assumed that the reduction in peak current did not result in lower NTC temperature and the over temperature is activated.
- When the low-level  $V_{deact(tmr)NTC}$  is reached within the time 100  $\mu s$ , it is assumed that the pin is pulled down externally and the restart function is not triggered. Instead, the output current is reduced to zero. PWM current regulation can be implemented in this way. The output current rises again when the voltage is above level of  $V_{deact(tmr)NTC}$ .

The value of the NTC resistor can be calculated, for a specific maximum ambient temperature, using [Equation 31](#):

$$RT1_{NTC} \text{ at } T_{amb} \text{ of } 100 \text{ }^\circ\text{C} = \frac{V_{th(NTC)high}}{I_{th(NTC)high}} \tag{31}$$

For example, start output current reduction at  $T_{amb} = 100 \text{ }^\circ\text{C}$ ,  $RT1_{NTC}$  must be 10.64  $k\Omega$ . Refer to the NTC's own data sheet for the type selection, what the value will be for 25  $^\circ\text{C}$ .

The control sensitivity can be calculated using [Equation 32](#):

$$\text{Control sensitivity} = \frac{(V_{th(ocp)SOURCE} - V_{th(ocp)SOURCE(low)})}{(V_{th(NTC)high} - V_{th(NTC)low})} \tag{32}$$

Maximum output power reduction using the NTC pin is 50 %. A 10 % output power reduction is obtained by reducing the voltage on the NTC pin to 30 mV.

#### 4.5.2.2 Soft-start function

The NTC pin can be used to make a soft start function. During converter start, the level on the NTC pin is low. Connecting capacitor C6 (possibly in parallel with RT1<sub>NTC</sub>) a time constant can be defined causing level on pin NTC to slowly increase.

When the threshold level  $V_{th(NTC)low}$  (Figure 4, line 3) is passed, the convertor starts at half the maximum current. The output current slowly increases and is at its maximum when the threshold level  $V_{th(NTC)high}$  (Figure 4, line 4) is reached. Using Equation 33, the value of capacitor C6 can be calculated as function of the required soft start time  $t_{soft-start}$ :

$$C6 = \frac{(I_{th(NTC)off} \cdot t_{soft-start})}{V_{th(NTC)high}} \quad (33)$$

When capacitor C6 is larger than 1 nF, the NTC thermal protection becomes a latched protection instead of an auto-reset function.

#### 4.5.2.3 PWM current regulation

The easiest way to dim a LED string is to decrease the forward current. Pulse-Width Modulation (PWM) can effectively control the pulse width and duty cycle causing the LED light to vary its intensity.

The PWM method of current regulation is the actual start and restart of the LED current for short periods of time. The frequency of this start-restart cycle must be faster than the human eye can detect to avoid a flickering effect. About 200 Hz or faster is usually acceptable.

To produce the appropriate frequency and pulse width, the LED drive circuitry requires electronics that generate a digital control signal with variable on-time, for example, a microcontroller with a PWM I/O. This signal can be connected to the NTC pin. The dimming of the LED becomes proportional to the duty cycle of the control signal, as can be seen in the boundary conduction mode (Equation 1):

$$I_{LED} = \frac{1}{2} I_{peak} \text{ (see equation 1)} \quad (34)$$

$$I_{LED(dim)} = \frac{1}{2} I_{peak} \cdot \delta \quad (35)$$

Where  $\delta$  is the duty cycle of the PWM signal.

### 4.6 Output current ripple calculation (low-ripple configuration only)

Component C3 filters the current through the LEDs, so this current approaches the average current through the inductor. The remaining variation is called ripple and can be expressed as percentage of the average current. If the current waveform is symmetrical, which is the case with buck converters, the ripple current is also be symmetrical.

Equation 36 gives an approximate result of the ripple current:

$$C3 = \frac{I}{2 \cdot \pi} \cdot \frac{I}{f_{sw} \cdot ripple \% \cdot R_{dyn}} \quad (36)$$

In [Equation 36](#),  $R_{dyn}$  is the differential resistance of the LED string at the average rated current. This value is derived by taking the tangent of the LED's UI graph ([Figure 2](#)). It is not the division between voltage and current at the point of operation of the LED.

$$R_{dyn} = \frac{\Delta V_{LED}}{\Delta I_{LED}} \quad (37)$$

For example, 10 LED's are used in series at 100 mA. Each LED has a dynamic resistance of 1  $\Omega$ , so the total dynamic resistance is 10  $\Omega$ . At a ripple of 5 % and a frequency of 100 kHz, C3 is 3.18  $\mu\text{F}$ . Use 3.3  $\mu\text{F}$ .

The value calculated with [Equation 35](#) is intended to filter ripple current caused by converter operation. This value is not intended to filter current variation due to input voltage fluctuation. The input voltage ripple, especially when rectifying and buffering 50 Hz or 60 Hz mains voltage, must be filtered/buffered so that the voltage over the converter does not drop below the minimum working voltage  $V_{buff(min)}$ . See [Section 4.2.3.1](#) for details.

## 4.7 VCC generation

The SSL21081, the SSL21083, and the SSL2109 supply systems are shown in [Figure 5](#). At start-up, there is an internal current source connected to the HV pin. This current source provides sufficient internal power to supply the VCC pin until the  $V_{CC(start)}$  level is reached. The converter then starts switching. To provide optimal efficiency, the internal current source switches off when either sufficient power is generated via the DVDT pin or when sufficient power is generated via an external current source connected to pin VCC. The external power supply connected to pin VCC can be taken from the rectified mains buffer circuit output using a resistor or generated via an auxiliary winding. More information can be found in the application note "*Buck converter for SSL applications*" ([AN10876](#)), *section 7* ([Ref. 1](#)).

The supply generated via the DVDT pin is described in [Section 4.7.1](#). To be able to work correctly with the Hotaru wall switches which have an indicator light that requires power when the dimmer is in the during off position (see [Section 4.7.3](#)),  $I_{stb(HV)}$  is active during the off state.



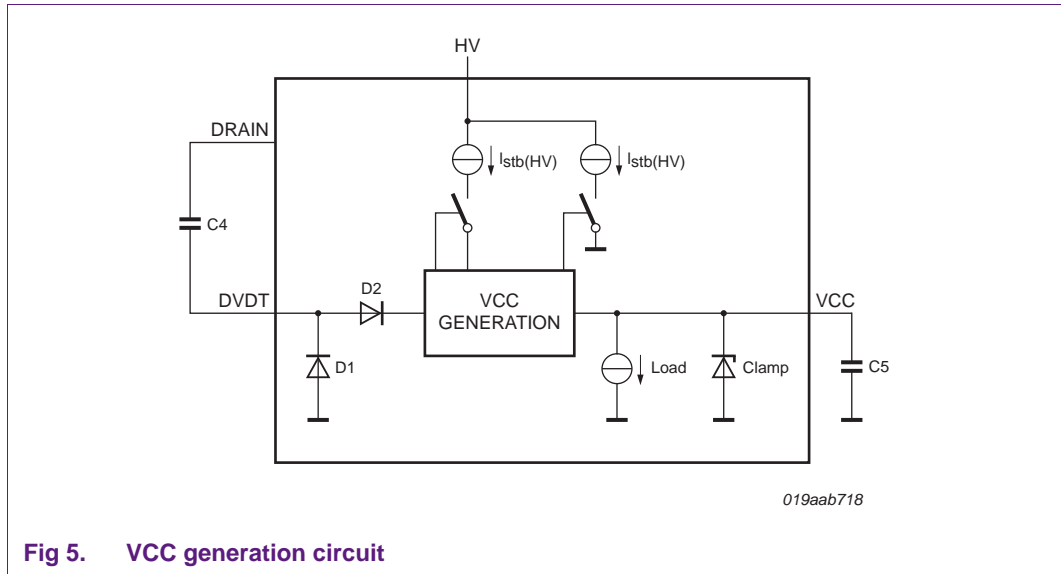

Fig 5. VCC generation circuit

#### 4.7.1 VCC supply via DVDT pin

To avoid an additional inductor winding, it is possible to supply the SSL21081, the SSL21083, or the SSL2109 using the DVDT pin. In this application, a capacitor must be connected between the DRAIN pin and the DVDT pin. The power consumption of the IC is such that the VCC pin can be supplied with the AC current during the rising edge of the DRAIN pin. Diode D2 prevents discharge of the VCC pin during the falling edge of the DRAIN pin. The built-in clamp circuit limits the level of the VCC pin to its maximum voltage.

DVDT capacitor C4 can be calculated using [Equation 38](#), [Equation 39](#) and [Equation 40](#):

$$I_{CC} = f_{sw} \cdot Q_g + 500 \cdot 10^{-6} \tag{38}$$

$$I_{clamp} = I_{CC} \cdot 0.25 \tag{39}$$

$$C4 = \frac{I_{clamp} + I_{CC}}{f_{sw} \cdot (V_{DRAIN} \cdot \sqrt{2} - V_{CC} - I \cdot V_F)} \tag{40}$$

A forward voltage of 0.65 V can be taken for  $V_F$ .

For example,  $C4 = 110 \text{ pF}$  for:  $f = 70 \text{ kHz}$ , charge ratio MOSFET  $Q_g = 4 \times 10^{-9}$ ,  $I_{CC} = 0.8 \text{ mA}$ ,  $V_{DRAIN} = 100 \text{ V}$ ,  $V_{CC} = 15 \text{ V}$ .

To limit the load current, the maximum value of capacitor C4 must not be higher than 220 pF.

#### 4.7.2 VCC supply alternatives

Next to the option to supply the VCC pin via the DVDT pin, following alternatives are also possible:

- Supply continuously via the HV pin, do not insert external current into the VCC pin. This option is only allowed for 100 V (AC) to 120 V (AC) applications and if extra IC power dissipation is allowed. This also reduces converter efficiency.

- Connect a resistor between the rectified mains input voltage and the VCC pin to supply the IC. No external Zener diode is required due to the internal clamp circuit.
- Supply via an auxiliary inductor winding. This circuit consists of a capacitor, a rectifier diode and a current limiting resistor. No external Zener diode is required due to the internal clamp circuit. This option is described in detail in the application note “*Buck converter for SSL applications*” (AN10876) (Ref. 1).

**Table 3. Supply systems for VCC**

VCC supply source	Remarks
Internal current source via HV pin <sup>[1]</sup>	used when the extra power dissipation in IC is no problem. <sup>[2]</sup>
Resistor from rectified mains input voltage to supply VCC pin	used when <sup>[1]</sup> <sup>[2]</sup> <sup>[3]</sup> are not an option.
Use auxiliary winding to supply VCC pin	recommended for universal mains applications
Via DVDT pin	most economic solution for dedicated applications

[1] Only for 100 V (AC) to 120 V (AC) applications.

[2] C4 not required.

[3] Internal current source via HV pin.

### 4.7.3 Hotaru switch

To be able to function correctly with Hotaru type switches with built-in indicator, sufficient load is drawn by the HV pin during standby.

## 5. Power calculations

The resulting efficiency of a buck converter is often one of the critical specifications for the design. One of the things to consider is that efficiency is always relative. Some of the losses in a buck converter (for example the IC VCC generation), are fixed and depend on the IC. Efficiency tends to decrease at lower output power due to of these fixed losses.

The variable losses consist of a number of factors and these are discussed in detail in the application note “*Buck converter for SSL applications*” (AN10876) (Ref. 1) which can be used to determine the total system losses.

## 6. Current tolerance and stability

### 6.1 Current tolerance

In essence, there are only two main components that determine current tolerance: the spread on detection voltage and the tolerance of the sense resistor. This can be derived from [Equation 41](#):

$$\Delta I_{LED} = \Delta I_{peak} = \Delta V_{th(ocp)} + \Delta R I \tag{41}$$

For example,  $V_{th(ocp)min} = 0.48 \text{ V}$ ,  $V_{th(ocp)avg} = 0.50 \text{ V}$ ,  $V_{th(ocp)max} = 0.52 \text{ V}$ ,  $\Delta V_{th(ocp)} = \pm 4 \%$ ,  $\Delta R1 = \pm 1 \%$ ,  $I_{LED} = \pm 5 \%$ .

There is some influence possible by variation of  $C_P$  and  $L_P$  with valley detection. However, in practice, the time influenced is much smaller than the total cycle time.

For example:  $\Delta L_P = 10\%$ ,  $\delta_4 / T = 0.052$ ,  $\Delta I_{LED} = 0.5 \times \Delta L_P \times 0.05 = 0.25\%$ .  
(see [Figure 3](#))

## 6.2 Current stability

Buck converters using peak current control seldom have stability issues because the current is controlled per cycle and it is intrinsically stable. If another means is used to stabilize the current, like current mirror detection, accuracy might increase but the loop response must be calculated.

The main component that determines response at peak current control is output capacitor C3. It has to be charged and discharged. At switch on, the discharged capacitor needs to reach the operating working voltage before any current flows through the LED's and light is produced. This time is equal to the charge time of [Equation 42](#)

$$\Delta t \geq \frac{\Delta V \cdot C3}{I_{CC}} \quad (42)$$

For example: With  $\Delta V = 100\text{ V}$ ,  $I_{CC} = 700\text{ mA}$  and  $C3 = 3.3\text{ }\mu\text{F}$ ,  $\Delta t$  is at least  $471\text{ }\mu\text{s}$ .

There is also a maximum capacitor size for C3 to prevent the converter triggering SWP (SSL21081T, SSL21083T, and SSL2109T only). The maximum size can be calculated:

$$\text{Maximum } C3 = \frac{3.5 \cdot I \cdot 10^{-7}}{L} \quad (43)$$

At converter turn-off, the diode characteristic of the LED come in play. Instead of a sudden drop in current, it drops exponentially, starting with the nominal current. The light slowly fades until it is not visible. In practice, this might take several seconds.

Since the LEDs are placed in a self-rectification loop with the freewheel diode, any capacitive coupling on the drain-side, or inductive coupling over the loop with an AC source will induce a current through the LEDs. Even a small current of  $100\text{ }\mu\text{A}$  for instance, may be visible. This can happen if large, ungrounded objects such as heat-sinks connected to phase, are in close proximity of the LEDs.

## 7. Inductor design parameters

In buck converter designs, the importance of the main inductor L2 quality is often underestimated. To achieve a highly efficient solution, not only the inductance value but also the resistive losses, saturation current, proximity losses, core losses, parasitic capacitance and stray magnetic fields are important.

Not understanding the functionality and implementing without an optimized component results in either, inferior performance or an impractical design. Detailed information on how to determine the correct inductor, is given in the application note "Buck converter for SSL applications" (AN10876), section 4.6 ([Ref. 1](#)).

## 8. Summary

---

This document gives an overview of operations and relevant calculations used when designing a buck converter with low-ripple configuration with the SSL21081, the SSL21083, and the SSL2109 platforms operating in boundary conduction mode. It explains why valley detection is a key feature and it shows how a number of key components can be calculated.

A more detailed description of buck converters with the specific components properties and their contribution to several key parameters can be found in the general application note for buck converters, *"Buck converter for SSL applications"* (AN10876) ([Ref. 1](#)).

## 9. Abbreviations

**Table 4. Abbreviations**

Acronym	Description
BCM	Boundary Conduction Mode
CCM	Continuous Conduction Mode
DCM	Discontinuous Conduction Mode
EMC	ElectroMagnetic Compatibility
EMI	ElectroMagnetic Interference
LED	Light Emitting Diode
MOSFET	Metal-Oxide Semiconductor Field-Effect Transistor
OCP	OverCurrent Protection
OSP	Output Short Protection
OTP	OverTemperature Protection
PCB	Printed-Circuit Board
PWM	Pulse-Width Modulation
SSL	Solid State Lighting
SWP	Short-Winding Protection
UVLO	UnderVoltage LockOut

## 10. References

- [1] **AN10876** — Application note: Buck converter for SSL applications.
- [2] **SSL21081\_SSL21083** — Data sheet: Compact non-dimmable LED driver IC.
- [3] **SSL2109\_SER** — Data sheet: Drivers for LED lighting
- [4] **AN11136** — Application note: SL2109T/AT/SSL2129AT controller for SSL applications

## 11. Legal information

### 11.1 Definitions

**Draft** — The document is a draft version only. The content is still under internal review and subject to formal approval, which may result in modifications or additions. NXP Semiconductors does not give any representations or warranties as to the accuracy or completeness of information included herein and shall have no liability for the consequences of use of such information.

### 11.2 Disclaimers

**Limited warranty and liability** — Information in this document is believed to be accurate and reliable. However, NXP Semiconductors does not give any representations or warranties, expressed or implied, as to the accuracy or completeness of such information and shall have no liability for the consequences of use of such information. NXP Semiconductors takes no responsibility for the content in this document if provided by an information source outside of NXP Semiconductors.

In no event shall NXP Semiconductors be liable for any indirect, incidental, punitive, special or consequential damages (including - without limitation - lost profits, lost savings, business interruption, costs related to the removal or replacement of any products or rework charges) whether or not such damages are based on tort (including negligence), warranty, breach of contract or any other legal theory.

Notwithstanding any damages that customer might incur for any reason whatsoever, NXP Semiconductors' aggregate and cumulative liability towards customer for the products described herein shall be limited in accordance with the *Terms and conditions of commercial sale* of NXP Semiconductors.

**Right to make changes** — NXP Semiconductors reserves the right to make changes to information published in this document, including without limitation specifications and product descriptions, at any time and without notice. This document supersedes and replaces all information supplied prior to the publication hereof.

**Suitability for use** — NXP Semiconductors products are not designed, authorized or warranted to be suitable for use in life support, life-critical or safety-critical systems or equipment, nor in applications where failure or malfunction of an NXP Semiconductors product can reasonably be expected to result in personal injury, death or severe property or environmental damage. NXP Semiconductors and its suppliers accept no liability for inclusion and/or use of NXP Semiconductors products in such equipment or applications and therefore such inclusion and/or use is at the customer's own risk.

**Applications** — Applications that are described herein for any of these products are for illustrative purposes only. NXP Semiconductors makes no representation or warranty that such applications will be suitable for the specified use without further testing or modification.

Customers are responsible for the design and operation of their applications and products using NXP Semiconductors products, and NXP Semiconductors accepts no liability for any assistance with applications or customer product

design. It is customer's sole responsibility to determine whether the NXP Semiconductors product is suitable and fit for the customer's applications and products planned, as well as for the planned application and use of customer's third party customer(s). Customers should provide appropriate design and operating safeguards to minimize the risks associated with their applications and products.

NXP Semiconductors does not accept any liability related to any default, damage, costs or problem which is based on any weakness or default in the customer's applications or products, or the application or use by customer's third party customer(s). Customer is responsible for doing all necessary testing for the customer's applications and products using NXP Semiconductors products in order to avoid a default of the applications and the products or of the application or use by customer's third party customer(s). NXP does not accept any liability in this respect.

**Export control** — This document as well as the item(s) described herein may be subject to export control regulations. Export might require a prior authorization from competent authorities.

**Evaluation products** — This product is provided on an "as is" and "with all faults" basis for evaluation purposes only. NXP Semiconductors, its affiliates and their suppliers expressly disclaim all warranties, whether express, implied or statutory, including but not limited to the implied warranties of non-infringement, merchantability and fitness for a particular purpose. The entire risk as to the quality, or arising out of the use or performance, of this product remains with customer.

In no event shall NXP Semiconductors, its affiliates or their suppliers be liable to customer for any special, indirect, consequential, punitive or incidental damages (including without limitation damages for loss of business, business interruption, loss of use, loss of data or information, and the like) arising out of the use of or inability to use the product, whether or not based on tort (including negligence), strict liability, breach of contract, breach of warranty or any other theory, even if advised of the possibility of such damages.

Notwithstanding any damages that customer might incur for any reason whatsoever (including without limitation, all damages referenced above and all direct or general damages), the entire liability of NXP Semiconductors, its affiliates and their suppliers and customer's exclusive remedy for all of the foregoing shall be limited to actual damages incurred by customer based on reasonable reliance up to the greater of the amount actually paid by customer for the product or five dollars (US\$5.00). The foregoing limitations, exclusions and disclaimers shall apply to the maximum extent permitted by applicable law, even if any remedy fails of its essential purpose.

**Translations** — A non-English (translated) version of a document is for reference only. The English version shall prevail in case of any discrepancy between the translated and English versions.

### 11.3 Trademarks

Notice: All referenced brands, product names, service names and trademarks are the property of their respective owners.

**GreenChip** — is a trademark of NXP B.V.

## 12. Contents

<b>1</b>	<b>Introduction</b> .....	<b>3</b>
1.1	Type number overview .....	3
<b>2</b>	<b>Basic theory of operation</b> .....	<b>3</b>
<b>3</b>	<b>Functional description</b> .....	<b>4</b>
<b>4</b>	<b>Step-by-step design procedure</b> .....	<b>5</b>
4.1	Basic configuration .....	5
4.2	Input section .....	7
4.2.1	OverVoltage Protection (OVP) .....	7
4.2.2	OVP and inrush peak current protection .....	7
4.2.3	Buffer circuit with EMI filter .....	8
4.2.3.1	Buffer capacitor calculation (low-ripple configuration only) .....	8
4.2.3.2	EMI filter .....	9
4.3	Buck converter inductor dimensioning .....	9
4.4	Valley detection .....	10
4.5	SSL21081, SSL21083, and SSL2109 protection circuits .....	13
4.5.1	OverCurrent Protection (OCP) .....	13
4.5.2	NTC protection and control functions .....	13
4.5.2.1	Thermal protection .....	13
4.5.2.2	Soft-start function .....	15
4.5.2.3	PWM current regulation .....	15
4.6	Output current ripple calculation (low-ripple configuration only) .....	15
4.7	VCC generation .....	16
4.7.1	VCC supply via DVDVT pin .....	17
4.7.2	VCC supply alternatives .....	17
4.7.3	Hotaru switch .....	18
<b>5</b>	<b>Power calculations</b> .....	<b>18</b>
<b>6</b>	<b>Current tolerance and stability</b> .....	<b>18</b>
6.1	Current tolerance .....	18
6.2	Current stability .....	19
<b>7</b>	<b>Inductor design parameters</b> .....	<b>19</b>
<b>8</b>	<b>Summary</b> .....	<b>20</b>
<b>9</b>	<b>Abbreviations</b> .....	<b>21</b>
<b>10</b>	<b>References</b> .....	<b>21</b>
<b>11</b>	<b>Legal information</b> .....	<b>22</b>
11.1	Definitions .....	22
11.2	Disclaimers .....	22
11.3	Trademarks .....	22
<b>12</b>	<b>Contents</b> .....	<b>23</b>

Please be aware that important notices concerning this document and the product(s) described herein, have been included in section 'Legal information'.

© NXP B.V. 2012.

All rights reserved.

For more information, please visit: <http://www.nxp.com>

For sales office addresses, please send an email to: [salesaddresses@nxp.com](mailto:salesaddresses@nxp.com)

Date of release: 23 October 2012

Document identifier: AN11041