



## System power supply board for digital solutions

---

### Introduction

This document describes a power supply reference board designed for powering digital applications, such as CPUs, FPGAs, memories, etc. The main purpose of the board is to illustrate the basic principles used for the design of the power supply and to give designers a usable prototype for testing and use.

The trend in recent years in the supplying of power to MCUs, CPUs, memories, FPGAs, etc. is to reduce the supply voltage, increase the supply current and provide different voltage levels for different devices in one platform. A typical example of this situation is the FPGA. The FPGA contains a core part which works at a low level voltage, the interface part placed between the core and the output, the system part, etc. It is important to note that each FPGA family has a slightly different voltage level and the trend is to decrease the voltage for each new family. The lowest operating voltage currently available is 1 V, and this can be expected to decrease to 0.9 V or 0.8 V in the near future. A similar situation exists with other digital applications. Typically, the main CPU, memory and interfaces require different supply voltage levels. Low operating voltages also present another challenge - transient. Digital devices are typically sensitive to voltage level. If the voltage drops below or crosses over a specific limit, the device is reset. This limit is typically  $\pm 3$  or  $\pm 5\%$ . On the other hand, digital device consumption can change very quickly (several amps in a few hundred nanoseconds). A power supply must be able to react very quickly with a minimum of over (or under) voltage, especially in cases where very low output voltage is required. There is additional stress placed on power supplies for digital applications in the industrial environment.

The industrial standard bus is 24 V, but this voltage fluctuates and the maximum input voltage level required can reach 36 V. Additional surge protection is also a mandatory part of power supply input for industrial applications.

The goal of the board described in this application note is to cover all of the issues outlined above. It is intended mainly to satisfy industrial input requirements (operating voltages up to 36 V) and generate several output voltages for mid-range power applications (up to several amps). The main output voltage level can simply be set.

# Contents

- 1 Main characteristics ..... 4**
- 2 Description ..... 5**
  - 2.1 Input part ..... 6
- 3 PM6680A block ..... 7**
  - 3.0.1 Power management block ..... 8
  - 3.0.2 Start-up/enable block ..... 8
  - 3.0.3 Step-down parts ..... 10
  - 3.1 DC-DC converters based on the L5970AD ..... 14
  - 3.2 Reset circuit ..... 16
- 4 PCB layout ..... 18**
- 5 Bill of materials ..... 19**
- 6 Measurements ..... 23**
  - 6.1 PM6680A block - measurements ..... 23
    - 6.1.1 Efficiency and light load consumption modes ..... 23
    - 6.1.2 Output voltage ripple ..... 24
    - 6.1.3 Start-up sequence ..... 27
    - 6.1.4 Transient response ..... 27
  - 6.2 L5970AD blocks - measurements ..... 29
    - 6.2.1 Efficiency ..... 29
    - 6.2.2 Output voltage ripple ..... 30
    - 6.2.3 Transient ..... 33
- 7 References ..... 34**
- 8 Revision history ..... 34**

## List of figures

Figure 1.	The STEVAL-PSQ001V1 demo board	5
Figure 2.	Block diagram of System Supply board	5
Figure 3.	Schematic of input part	6
Figure 4.	Location and correct polarity of the input supply connector on the board	6
Figure 5.	Electrical diagram of the PM6680A section	7
Figure 6.	The placement of the jumpers for start-up/enable settings	9
Figure 7.	Skip mode connector	10
Figure 8.	Output connector	11
Figure 9.	Jumper placement for $V_{CORE}$ voltage level setting	12
Figure 10.	Jumper placement for $V_{I/O}$ voltage level setting	13
Figure 11.	Output voltages of L5970A parts	14
Figure 12.	Schematic of the two SMPS's based on the L5970AD	15
Figure 13.	Jumper placement for enable/disable function of analog output and output3	16
Figure 14.	Schematic of the reset circuit and board placement	17
Figure 15.	PCB top layer layout and first internal layer	18
Figure 16.	PCB second internal layer and bottom layer layout	18
Figure 17.	Efficiency of the dual step-down converter at full load	23
Figure 18.	PM6680A consumption at no load condition, in the different modes	24
Figure 19.	Output voltage ripple in different modes of light load operation	24
Figure 20.	Output voltage ripple of $V_{CORE}$ at the minimum input voltage (5 V)	25
Figure 21.	Output voltage ripple of $V_{CORE}$ at the maximum output voltage (36 V)	25
Figure 22.	Output voltage ripple of $V_{I/O}$ at the minimum input voltage (5 V)	25
Figure 23.	Output voltage ripple of $V_{I/O}$ at the maximum input voltage (36 V)	26
Figure 24.	Start-up without setting the sequence	26
Figure 25.	Start-up with a set sequence	26
Figure 26.	Load transient response on $V_{CORE}$ output	27
Figure 27.	Load transient response on $V_{I/O}$ output	28
Figure 28.	Efficiency of output 3, by input voltage level	29
Figure 29.	Efficiency of analog output, by input voltage level	30
Figure 30.	Analog 5 V - output voltage ripple	30
Figure 31.	$V_{SYS}$ - output voltage ripple	31
Figure 32.	Analog 3.3 V - output voltage ripple	31
Figure 33.	$V_{AUX}$ 2.5 V - output voltage ripple	32
Figure 34.	Transient response of $V_{SYS}$ based on the L5970AD	33
Figure 35.	Transient response of $V_{AUX}$ generated by the LDO KF25	33

# 1 Main characteristics

The main characteristics of the SMPS are listed below:

- Input: 5 V - 36 V DC, surge protection
- Outputs: the performance of the 6 outputs are described in [Table 1](#) below.

**Table 1. Output voltages (positive version)**

Label	V <sub>OUT</sub>	I <sub>OUT max</sub>	Tolerance
Output1 (V <sub>CORE</sub> )	Selectable from: 0.9, 1.0, 1.2, 1.5, 1.8 or 2.5 V	4 A continuous 6 A peak	3%
Output2 (V <sub>I/O</sub> )	Selectable from: 1.0, 1.2, 1.5, 1.8, 2.5 V or 3.3 V	2 A continuous 3 A peak	3%
Output3 V <sub>SYS</sub>	3.3 V	0.4 A (0.8 A peak)	4%
Output3 V <sub>AUX</sub>	2.5 V	0.4 A	2%
Analog 5 V	5 V	0.8 A	4%
Analog 3.3 V	3.3 V	0.15 A	2%

## 2 Description

The System Supply board described in this application note is a dedicated design which illustrates a typical solution for complete system supply, and can also be used as a direct supply for customer solutions during the design process.

**Figure 1. The STEVAL-PSQ001V1 demo board**

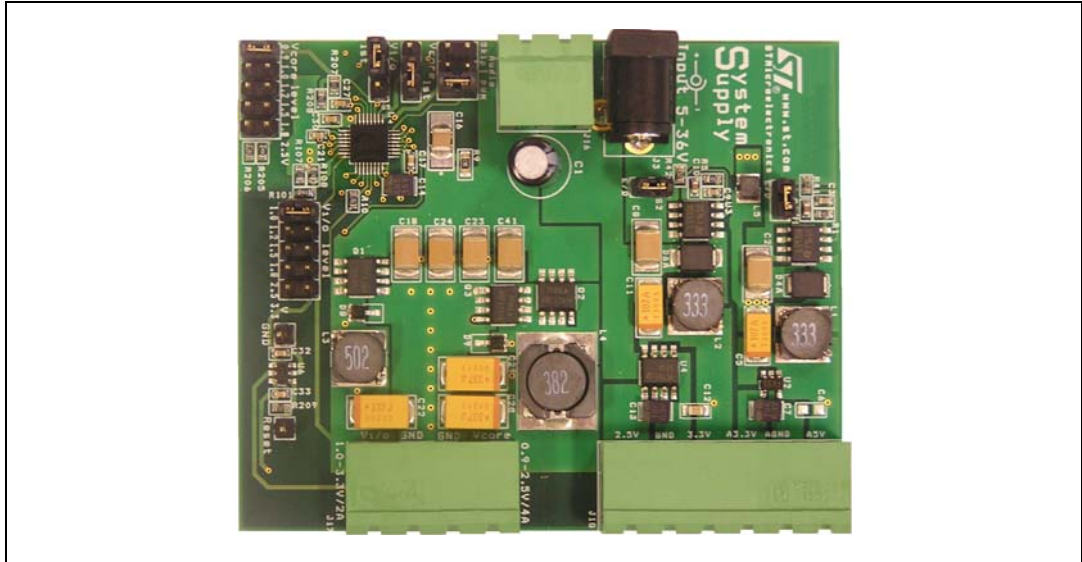

The block diagram of the System Supply board is shown in [Figure 2](#). There are four DC-DC converters, two linear regulators and a reset circuit. These parts are split into five relatively independent units: the input part, a dual DC-DC converter based on the PM6680A and generating 2 outputs (Output 1 and Output 2), two single DC-DC converters based on the L5970A (Output 3 and Output 4) with linear regulator, and the reset circuit.

**Figure 2. Block diagram of System Supply board**

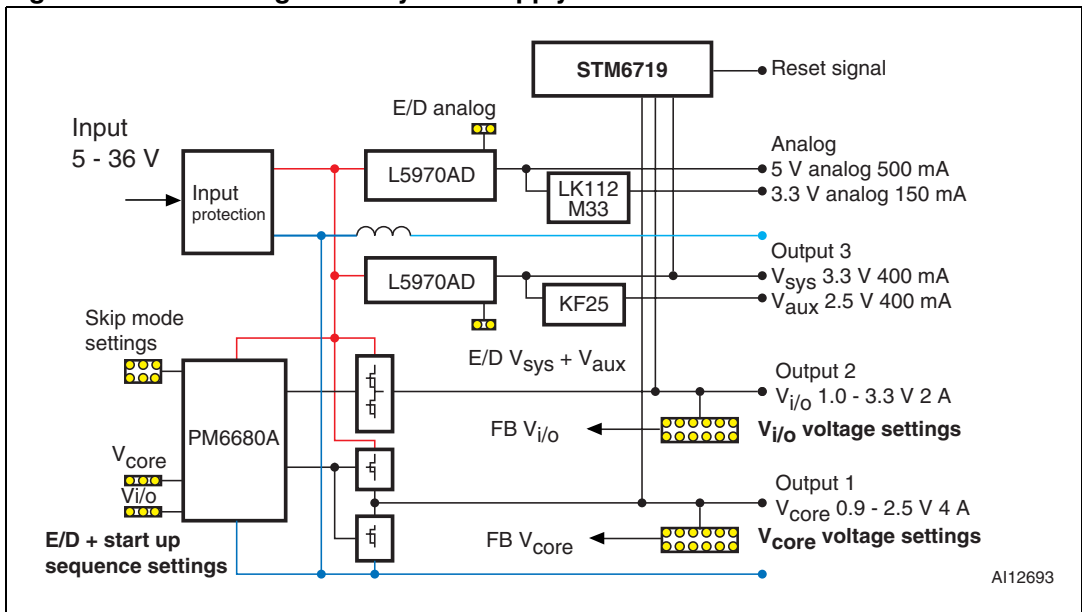

## 2.1 Input part

The input part shown in *Figure 3* consists of the input connectors (industrial - J16 or power jack - J3), input storage capacitor (C1) and transil (D1). The input electrolytic capacitor and transil serve to reduce input voltage spikes (surge).

**Figure 3. Schematic of input part**

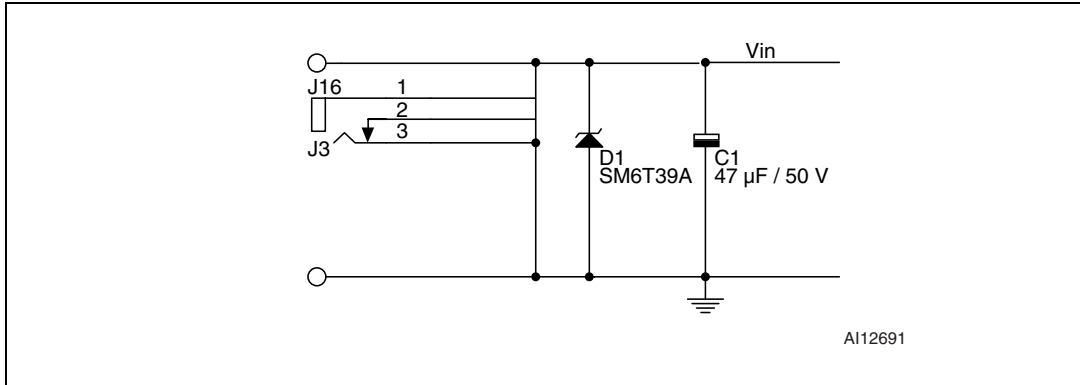

*Figure 4* displays the placement of the input connectors on the board. The board can be supplied either from the jack connector (J3) or the industrial removable terminal plate (J16). The polarity of the input voltage must be correctly applied in accordance with the illustration in *Figure 4*. If the connection is made incorrectly, the input protection D1 shorts the input voltage. It should be pointed out that the total input current is about 4 A at maximum output power and minimum input voltage.

**Figure 4. Location and correct polarity of the input supply connector on the board**

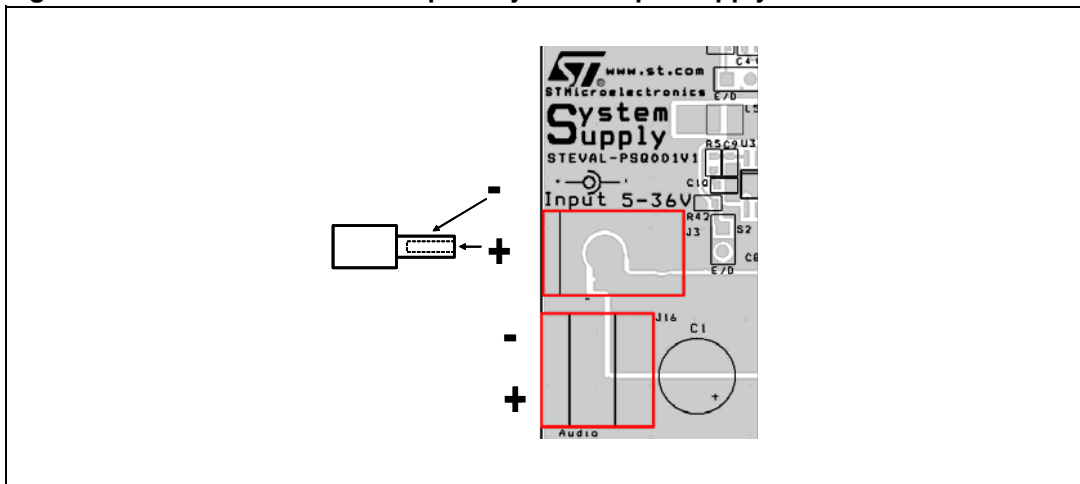

### 3 PM6680A block

Figure 5. Electrical diagram of the PM6680A section

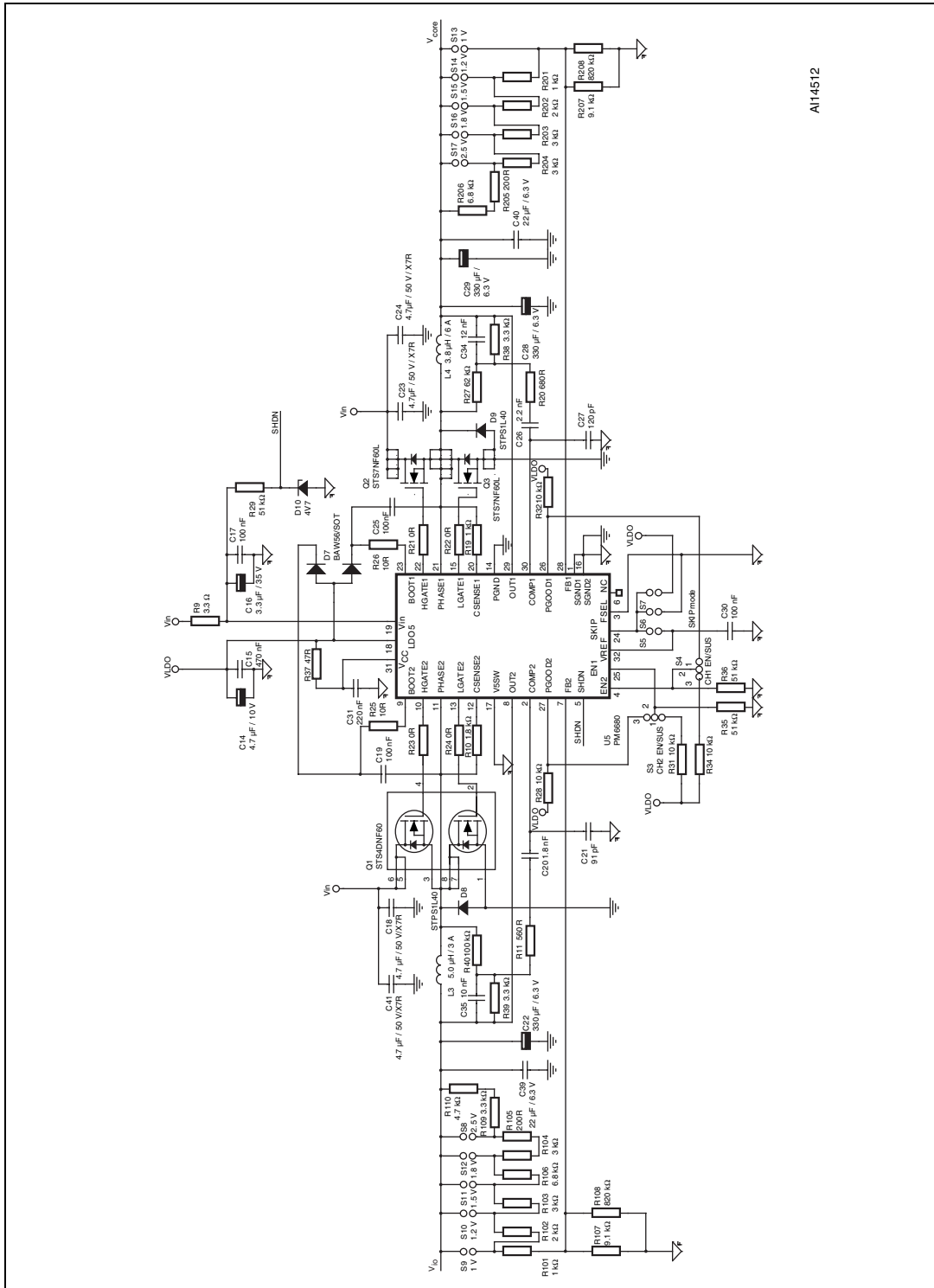

A114512

The PM6680A block is most important part of board. It contains two DC-DC converters. Each output has a selectable output voltage level. The first converter is capable of delivering up to 4 A for each voltage level, while the second converter can deliver up to 2 A on the output.

Both converters are controlled by the PM6680A device. The PM6680A is a dual step-down controller specifically designed to provide extremely high efficiency conversion, with loss-less current sensing. The constant on-time architecture assures fast load transient response and the embedded voltage feed-forward provides nearly constant switching frequency operation. An embedded integrator control loop compensates the DC voltage error due to the output ripple. The pulse skipping technique increases efficiency at very light loads. Moreover, a minimum switching frequency of 33 kHz is selectable to avoid audio noise issues. The PM6680A provides a selectable switching frequency, allowing either 200 / 300 kHz, 300 / 400 kHz or 400 / 500 kHz operation of the two switching sections. The output voltages OUT1 and OUT2 can be adjusted from 0.9 V to 5 V and from 0.9 V to 3.3 V, respectively. A detailed description of this device can be found in the datasheet.

*Figure 5* shows the full electrical diagram of the block with the PM6680A that controls the two DC-DC converters. The components around the PM6680A form several functional blocks: the power management block,  $V_{CORE}$  step down block,  $V_{I/O}$  step down block and start-up/enable control system block.

### 3.0.1 Power management block

The PM6680A has two supply voltage inputs -  $V_{CC}$  and  $V_{IN}$ . The  $V_{CC}$  pin should be connected to the 5 V bus (maximum input voltage is 6 V, minimum 4.5 V) and it is dedicated for the supply of the chip itself. The  $V_{IN}$  pin should be connected to the input power bus and it is used inside the chip for two reasons. The first is to supply the integrated LDO. The second is the fact that the controller must sense the converter input voltage level for proper functioning of the converter.

The  $V_{CC}$  pin is supplied from the integrated LDO (connected output of LDO and  $V_{CC}$ ) on the reference board. The V5SW feature of the LDO is disabled.

The power management block consists of components C14 - C17, C31, R9, R29, R37 and D10. The important parts of the power management block of the device are the low pass filters (R9, C16, C17 and R37, C31) applied to reduce the influence of transience on the device  $V_{CC}$  and  $V_{IN}$  main power inputs. The resistor R29 and the diode D10 generate the SHDN (shut down) signal, which is active in low level. This signal activates the PM6680A immediately after  $V_{IN}$  is connected to the input. The  $V_{REF}$  and LDO signals start to work simultaneously with activation of the SHDN pin.

### 3.0.2 Start-up/enable block

The PM6680A has several inputs and outputs dedicated to the control of each channel. Each channel has an independent Enable signal (EN - active in high level) and "power good" signal (PGOOD - open collector) activated by channel in cases where the output voltage is within 10% tolerance. These control pins can be used either for simple enabling/disabling or for delaying the start-up of one channel rather than another.

The jumpers S3 and S4 with resistors R28, R31, R32, R34, R35 and R36 are used for systems independently allowing either enabling or disabling of each channel or setting up a different start-up sequence of both channels. *Figure 6* displays the placement of jumpers S3 and S4 on the board, and the settings are shown in *Table 2*.



Figure 6. The placement of the jumpers for start-up/enable settings

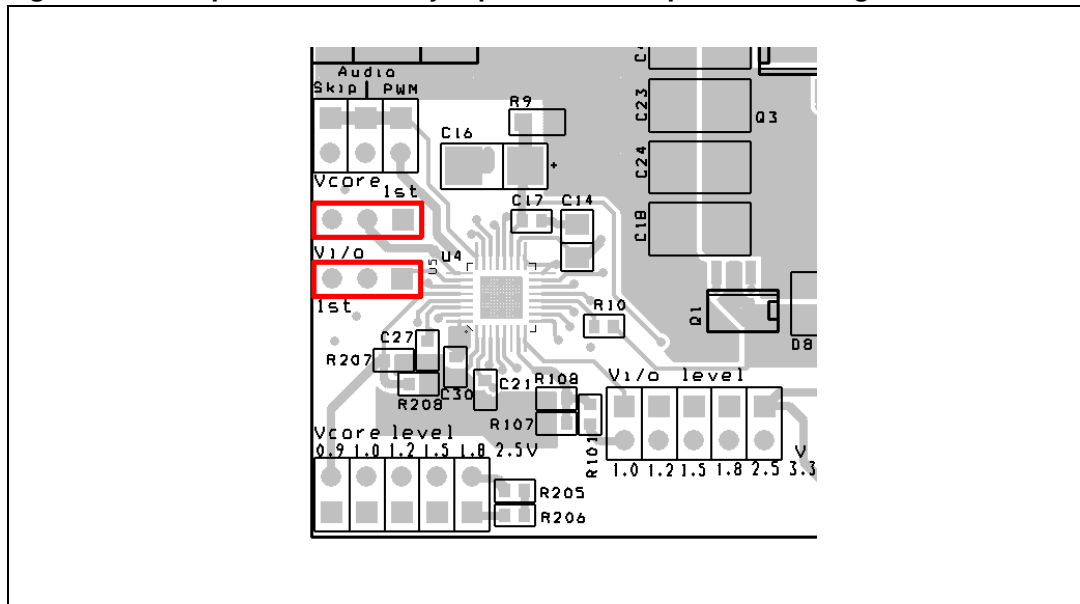

Table 2. Start-up/enable jumper settings

Jumper settings	Function
	Both channels are disabled. An open connector for each channel means that the channel is disabled.
	Both channels are disabled.
	Both channels are enabled and start at same time.
	V <sub>CORE</sub> voltage starts first, and V <sub>I/O</sub> starts second.
	V <sub>I/O</sub> voltage starts first, and V <sub>CORE</sub> starts second.

The Skip mode connector (shown in the schematic as S5 - S7) is dedicated for the control of Skip mode. This connector setting is common for both channels. [Figure 7](#) shows the placement of the Skip mode connector, while the settings are shown in [Table 3](#). There are three possible settings. Standard Skip mode, No Audible mode or PWM mode. In Standard Skip mode the converter reduces the switching frequency at light load to maintain good efficiency even in this condition. There is no lower limit for switching frequency. In No Audible mode the converter reduces switching frequency at light load, but this frequency never drops below 30 kHz to avoid possible audible noise caused by the mechanical

construction of passive components (inductors or ceramic capacitors). In PWM mode the converter maintains a constant switching frequency independently on the load.

The FSEL pin the PM6680A dedicated for operating frequency setting is connected to GND. This means that the switching frequency of the  $V_{CORE}$  branch is 200 kHz and switching frequency of  $V_{I/O}$  is 300 kHz.

**Figure 7. Skip mode connector**

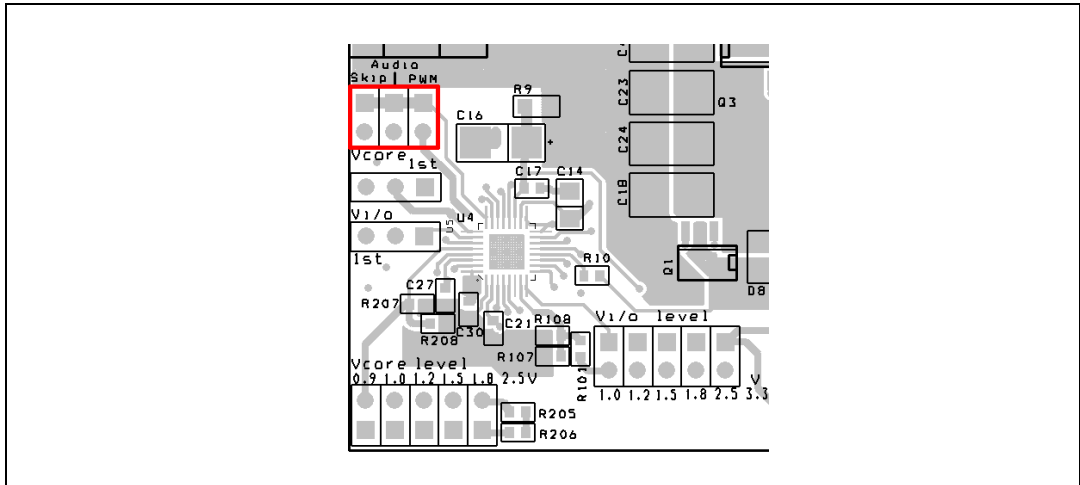

**Table 3. Skip mode connector jumper settings**

Jumper settings	Function
	Skip mode at light load.
	No Audible Skip mode at light load (frequency never drops below 30 kHz).
	PWM mode. Constant frequency even at light or zero load.

### 3.0.3 Step-down parts

The PM6680A is a dual step-down controller and drives two step-down converters. The schematic of both channels are almost identical, with only a few small differences. Since each channel is for a different output power, the main difference is in the components' values. [Figure 8](#) displays the output connector polarities of the PM6680A section.

Figure 8. Output connector

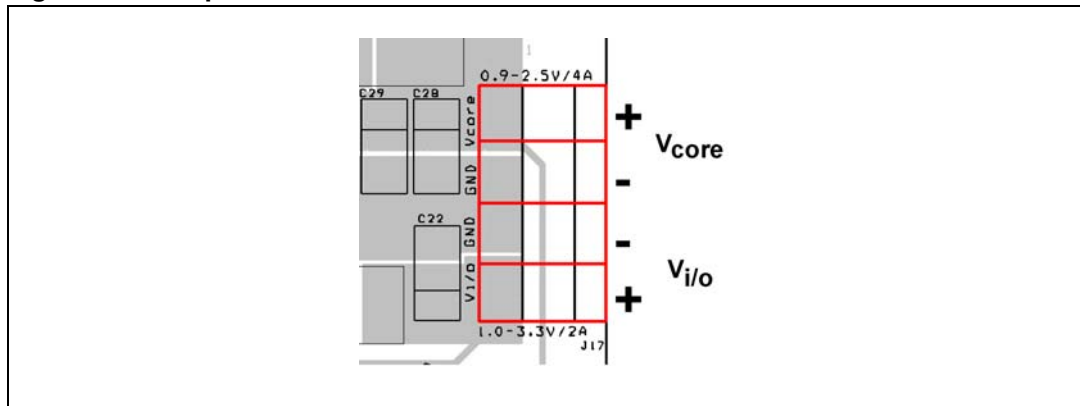

The power components of the step-down part are input capacitors (C23, C24 or C18, C41), the half bridge driver containing two N-channel MOSFETs (Q2, Q3 or Q1), inductors (L4 or L3) and output capacitors (C28, C29, C40 or C22, C39).

Ceramic high-capacitance capacitors are used as input capacitors. 60 V MOSFETs are used for the half bridge driver. A relatively high breakdown voltage is used to guarantee operation in industrial applications. Because the  $V_{I/O}$  output is designed for lower currents (2 A), both MOSFETs are integrated in one SO-8 package (Q1 - STS4NF60). This helps to reduce the size on the PCB. Two discrete MOSFETs (STS7NF60) are used for the  $V_{CORE}$  - higher power output (4 A). Schottky diodes are also used in each channel (D9 or D8). These diodes work mainly during dead time and are not mandatory for proper functioning, but their application increases efficiency.

The 5  $\mu$ H inductor (L3) is used for the  $V_{I/O}$  output with saturation current at 3 A. The inductor L4 has value of 3.8  $\mu$ H with saturation current at 6 A.

A combination of tantalum low ESR and ceramic type are used as output capacitors. Ceramic capacitors help to reduce total output ESR and reduce total output voltage ripple.

The PM6680A includes a half bridge driver for each channel. The external bootstrap diode and capacitor must be applied (D7, C19 or C25) in order to drive the gates of the high side MOSFETs.

The feedback signal is generated by the output voltage divider (R10x or R20x). The board allows the setting of different output voltages for both channels. [Figure 9](#) and [Figure 10](#) display the output voltage connector placement on the board for each channel. The jumper settings are shown in [Table 4](#) and [Table 5](#), respectively.

In classic Constant On Time control, the system regulates the valley value of the output voltage and not the average value. In this condition, the output voltage ripple is a source of DC static error. To compensate for this error, an integrator network is introduced in the control loop by connecting the signal output voltage to the COMP1/COMP2 pin through a capacitor (C20 or C26). An additional R-C network (R11 and C21 or R20 and C27) is implemented as a low pass filter to reduce noise on the input of the COMP pin.

Since the feedback signal of the SMPS working in Constant On Time control is directly connected to the PWM comparator, the stability of the SMPS is more sensitive to noise injected into the FB signal. It is possible to attenuate the affect of the noise to stabilize the SMPS by implementing the so called "Virtual ESR" network, which increases the amplitude of the feedback ripple voltage and improves signal-to-noise ratio. The Virtual ESR network does not increase the output ripple voltage. It is recommended to use the Virtual ESR network in cases where the output voltage ripple is below 30 mV. However, it is necessary to

take into consideration that the influence of noise on the performance of the SMPS strictly depends on the PCB layout. Therefore, the 30 mV is an indicative value. Virtual ESR Networks are applied for each channel on the reference board described in this application note. The main reason for this is the fact that the SMPS based on the PM6680A device can generate different output voltages at a wide input voltage range. As output voltage ripple depends also on input and output voltage level, there are configurations where the Virtual ESR network could be mandatory. Virtual ESR networks consists of R40, R39, C35 or R27, R38 or C34. The ESR network can be removed to observe influence of ESR network to board function. To remove the Virtual ESR Network, R40 and R27 must be removed and R39 and R38, respectively, must be shorted.

**Figure 9. Jumper placement for V<sub>CORE</sub> voltage level setting**

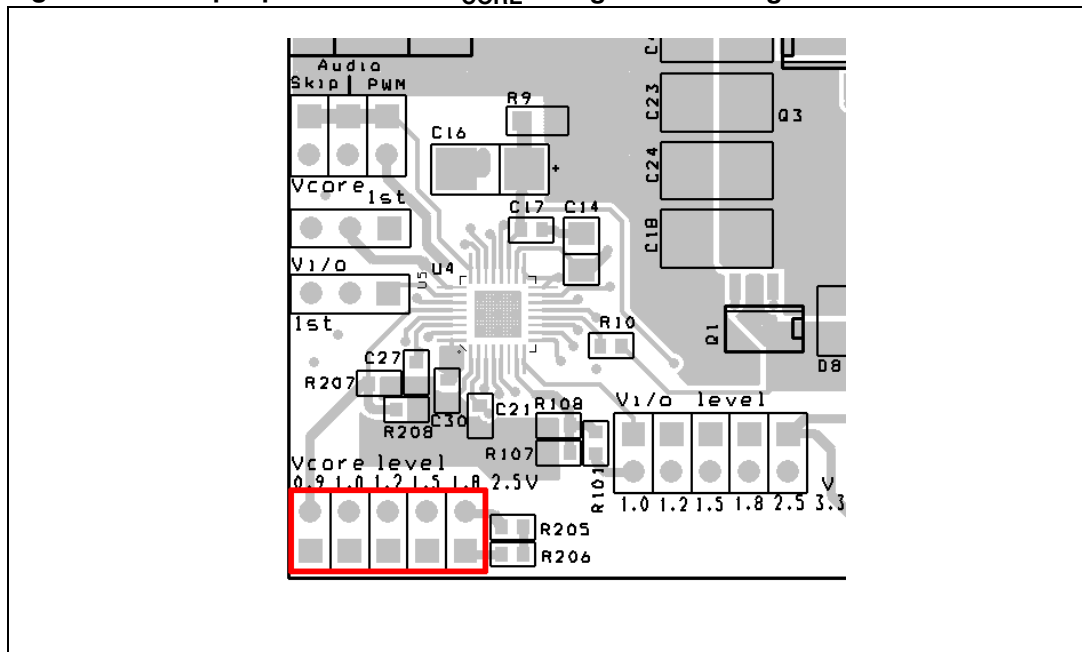

**Table 4. V<sub>CORE</sub> voltage level jumper settings**

Jumper settings	V <sub>CORE</sub>
	2.5 V
	1.8 V
	1.5 V
	1.2 V
	1.0 V
	0.9 V

Figure 10. Jumper placement for V<sub>I/O</sub> voltage level setting

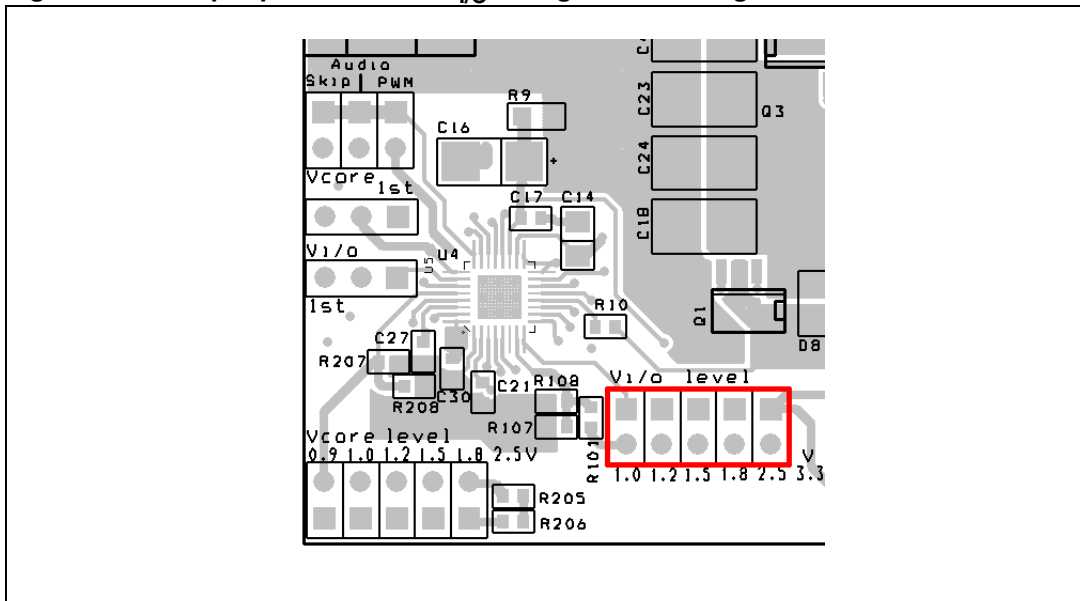

Table 5. V<sub>I/O</sub> voltage level jumper settings

Jumper settings	V <sub>CORE</sub>
	3.3 V
	2.5 V
	1.8 V
	1.5 V
	1.2 V
	1.0 V

### 3.1 DC-DC converters based on the L5970AD

There are two converters based on the L5970AD on the System Supply board: the analog output and  $V_{SYS}$  output voltage. *Figure 11* shows the arrangement of output voltages on connector J18.

**Figure 11. Output voltages of L5970A parts**

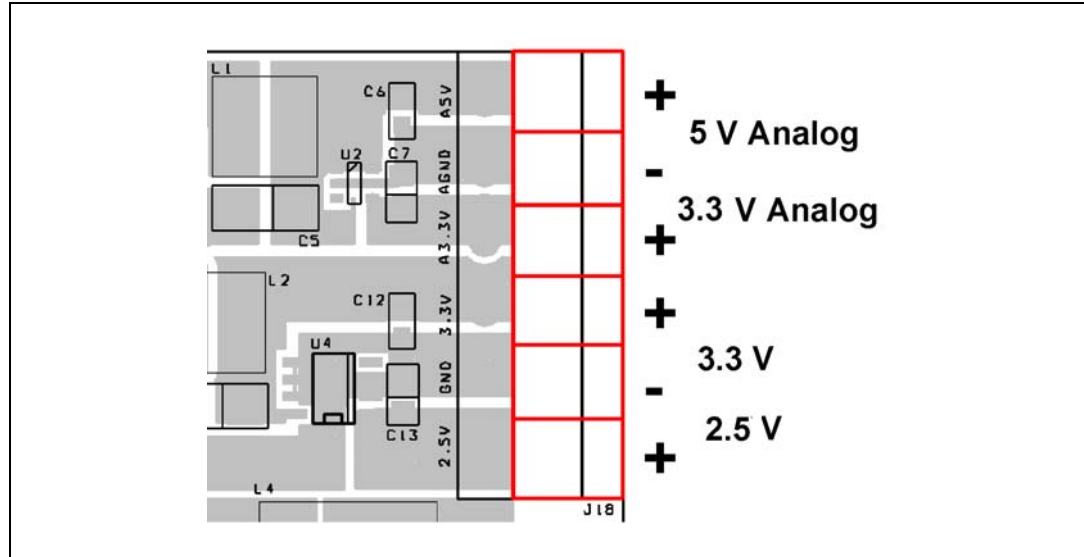

The L5970AD is a step-down monolithic power switching regulator with a switch current limit of 1.5 A, capable of delivering more than 1 A of DC current to the load depending on the application conditions. The output voltage can be set from 1.235 V to 35 V. The device uses an internal P-channel D-MOS transistor (with a typical  $R_{DS(ON)}$  of 200 m $\Omega$ ) as a switching element to avoid the use of a bootstrap capacitor and to guarantee high efficiency. An internal oscillator fixes the switching frequency at 500 kHz to minimize the size of external components. Having a minimum input voltage of only 4.4 V, it is particularly suitable for 5 V buses, found in all computer-related applications. Pulse-by-pulse current limiting with internal frequency modulation offers effective constant current short circuit protection.

The schematic of both SMPS's is displayed in *Figure 12*. As the schematic shows, designing with the L5970AD is very simple. It consists of a power part, feedback and enable/disable connectors. The power part contains an input capacitor (C2 or C8 - ceramic is recommended), an inductor (L1 or L2), an output capacitor (C5 or C11) and a freewheeling diode (D4 or D6). The feedback part consists of a voltage divider (R2, R3, R4 or R6, R7, R8) and a compensation RC network (R1, C3, C4 or R5, C9, C10).

Figure 12. Schematic of the two SMPS's based on the L5970AD

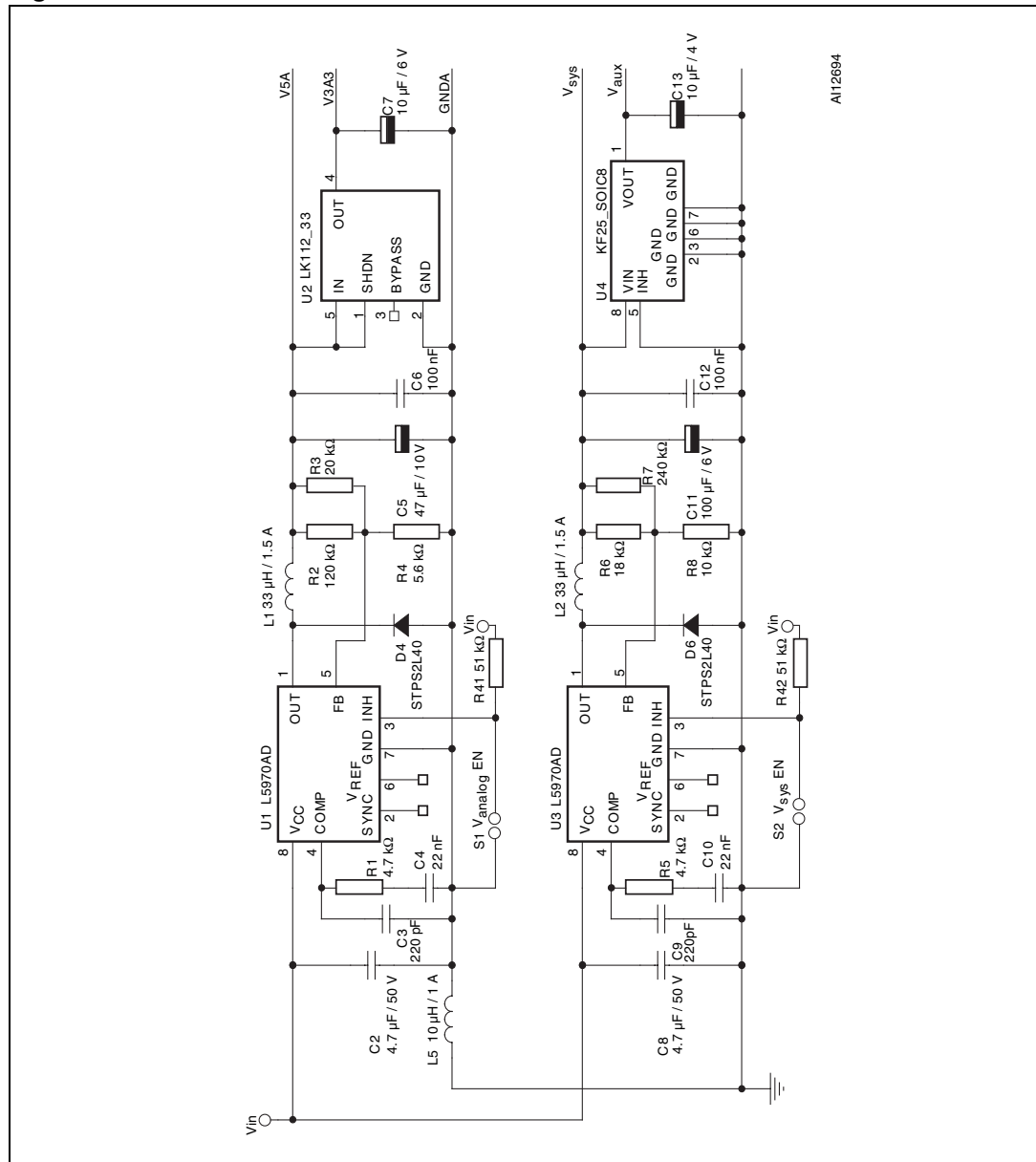

Both converters can be switched on or off using the inhibit pin of L5970AD connected to jumpers S1 and S2. If the jumper is left open, the DC-DC converter will not operate. Thus the jumper must be shorted for the converter to operate (see [Figure 13](#) for board placement of the jumper and [Table 6](#) for the jumper settings).

Figure 13. Jumper placement for enable/disable function of analog output and output3

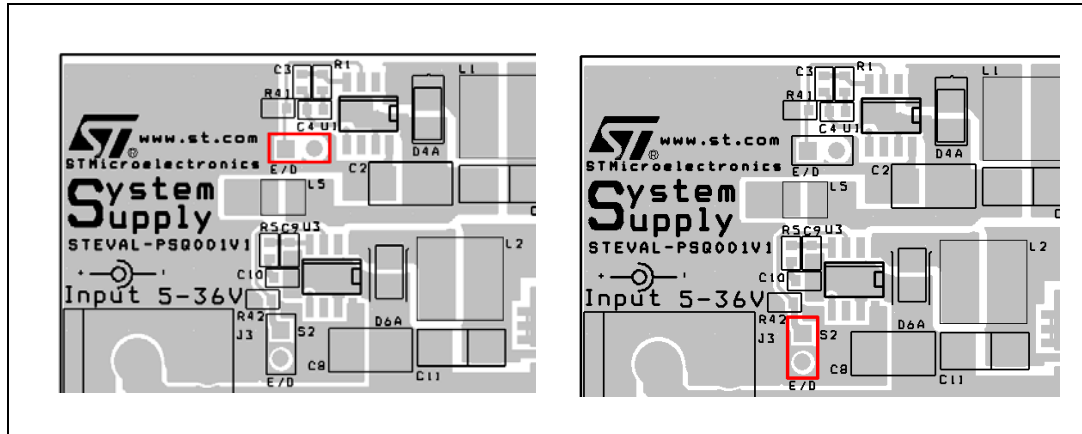





Table 6. Jumper settings for enable/disable function of analog output and output3

Jumper settings	V <sub>CORE</sub>
 E/D	Analog disable
 E/D	Analog enable
 E/D	Output3 disable
 E/D	Output3 enable

There is an LDO linear regulator (U2 and U4) on the output of each DC-DC converter. The LK112\_33 is a 3.3 V linear regulator in a SOT23-5 package. The KF25 is a very low dropout regulator with an output voltage of 2.5 V and output current of up to 400 mA.

### 3.2 Reset circuit

The board also features a reset circuit which supervises the output voltages. It is based on the STM6719 series of low voltage / low supply supervisors, which are designed to monitor three system power supply voltages. Two monitored supplies (V<sub>CC1</sub> and V<sub>CC2</sub>) have fixed (factory trimmed) thresholds (V<sub>RST1</sub> and V<sub>RST2</sub>). The third voltage is monitored using an externally adjustable RSTIN threshold (0.626 V internal reference). If any of the three monitored voltages drop below its factory-trimmed or adjustable thresholds, or if MR is asserted to logic low, an RST is asserted (driven low). Once asserted, RST is maintained at Low for a minimum delay period after ALL supplies rise above their respective thresholds and MR returns to High. This device is guaranteed to be in the correct reset output logic state when V<sub>CC1</sub> and / or V<sub>CC2</sub> is greater than 0.8 V. This device is available in a standard 6-pin SOT23 package.



Figure 14 shows the schematic and placement of the reset part on the board. Typically in real applications the reset circuit senses if the supply voltage drops below about 10% of nominal value. This feature cannot be implemented on the System Supply board due to the fact that the output voltage is selectable, while the reset voltage is factory set. There are several types of reset circuits in the STM6719 family (see datasheet). Of these, the STM6719TGWB6F was selected as optimal. The voltage thresholds of this device are 3.075 V, 1.11 V and 0.626 V.

**Figure 14. Schematic of the reset circuit and board placement**

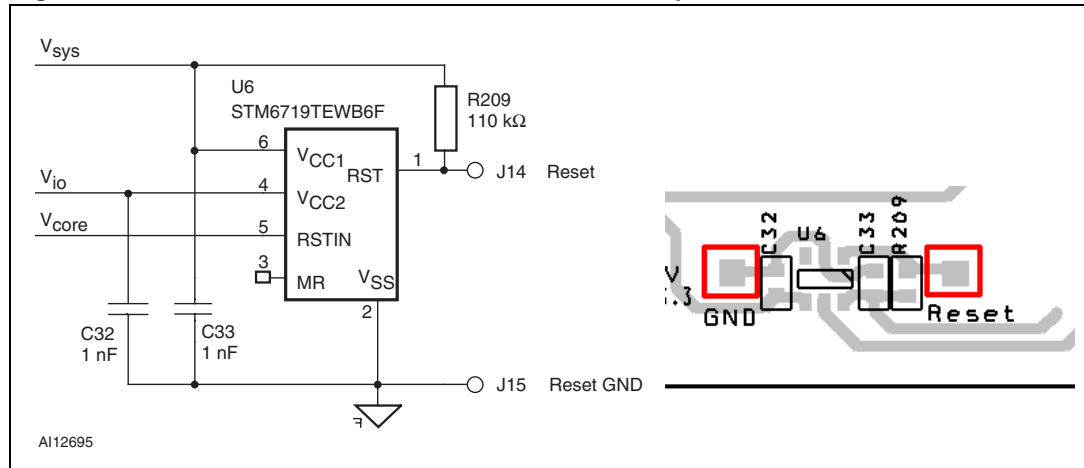

# 4 PCB layout

The System Supply board utilizes a four-layer PCB. The copper layout of each layer is shown in *Figure 15* and *Figure 16*. The top and bottom layers show also the placement of the components. To reduce the size of board while maintaining the ability to change some components, size 0603 was used for the majority of the passive components. All views of the PCB are from top side.

**Figure 15. PCB top layer layout and first internal layer**

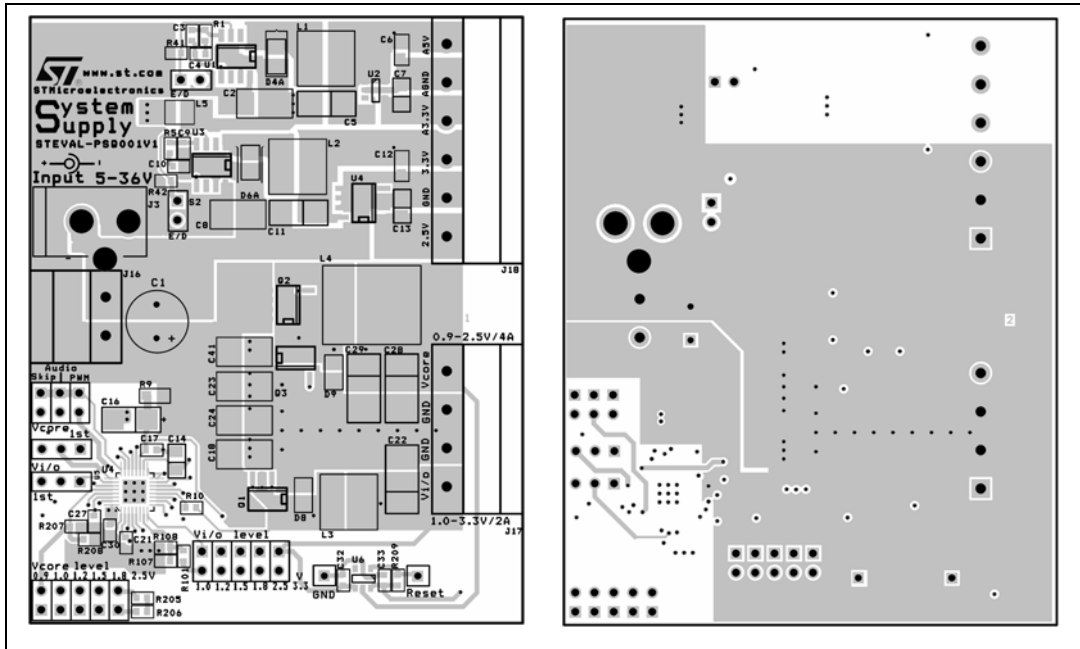

**Figure 16. PCB second internal layer and bottom layer layout**

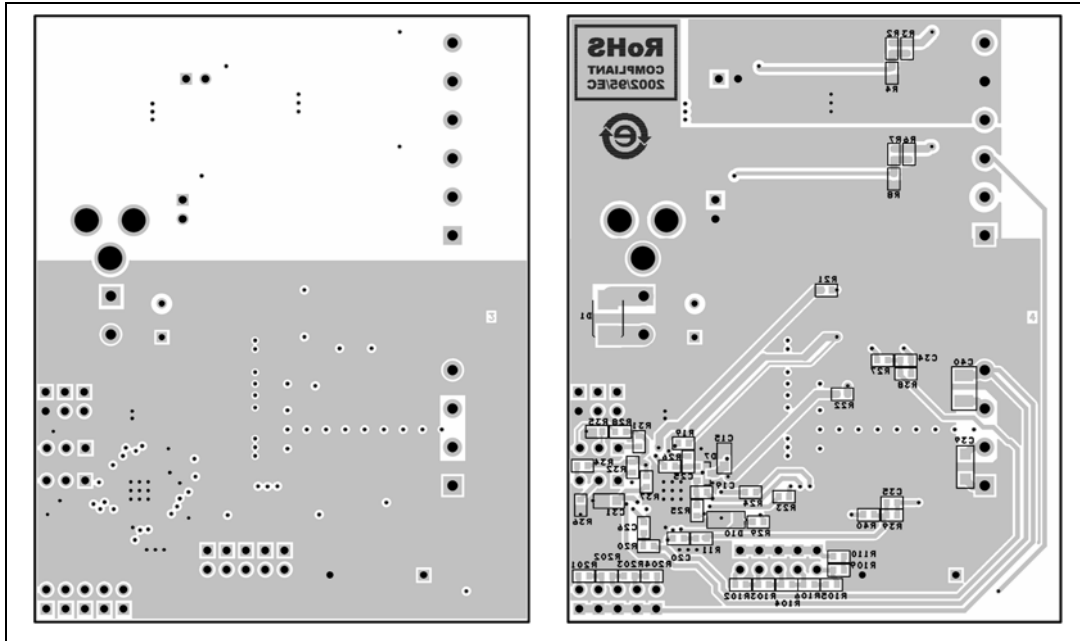

## 5 Bill of materials

Table 7. Bill of materials

Item	Part	Description	Type	Size	Manufacturer	Part number
1	C1	47 $\mu$ F / 50 V	TH	6.3 x 11		E47M/50VMXA RM5
2	C2	4.7 $\mu$ F / 50 V	SMD	1812	AVX	18125C475KAT2A
3	C3	220 pF	SMD	0603		
4	C4	22 nF	SMD	0603		
5	C5	100 $\mu$ F / 10 V	SMD	C	AVX	TPSC107M010X0150
6	C6	N.A.				
7	C7	10 $\mu$ F / 6 V	SMD	B		CTS 10M / 6.3 V
8	C8	4.7 $\mu$ F / 50 V	SMD	1812	AVX	18125C475KAT2A
9	C9	220 pF	SMD	0603		
10	C10	22 nF	SMD	0603		
11	C11	100 $\mu$ F / 10 V	SMD	C	AVX	TPSC107M010X0150
12	C12	100 nF	SMD	0805		
13	C13	10 $\mu$ F / 6.3 V	SMD	B		CTS 10 M / 6.3 V
14	C14	6.8 $\mu$ F / 10 V	SMD	B		CTS 6 M 8 / 10 V
15	C15	470 nF	SMD	0805		
16	C16	3.3 $\mu$ F / 50 V	SMD	1812		C1210C335K5RAC
17	C17	100 nF	SMD	0603		
18	C18	4.7 $\mu$ F / 50 V / X7R	SMD	1812	AVX	18125C475KAT2A
19	C19	100 nF	SMD	0603		
20	C20	1.8 nF	SMD	0603		
21	C21	100 pF	SMD	0603		
22	C22	330 $\mu$ F / 6.3 V	SMD	D	AVX	TPSD337M006X0045
23	C23	4.7 $\mu$ F / 50 V / X7R	SMD	1812	AVX	18125C475KAT2A
24	C24	4.7 $\mu$ F / 50 V / X7R	SMD	1812	AVX	18125C475KAT2A
25	C25	100 nF	SMD	0603		
26	C26	2.2 nF	SMD	0603		
27	C27	120 pF	SMD	0603		
28	C28	330 $\mu$ F / 6.3 V / 45 m $\Omega$	SMD	D	AVX	TPSD337M006X0045
29	C29	330 $\mu$ F / 6.3 V / 45 m $\Omega$	SMD	D	AVX	TPSD337M006X0045
30	C30	100 nF	SMD	0603		
31	C31	220 nF	SMD	0805		
32	C32	1 nF	SMD	0603		

Table 7. Bill of materials (continued)

Item	Part	Description	Type	Size	Manufacturer	Part number
33	C33	1 nF	SMD	0603		
34	C34	12 nF	SMD	0603		
35	C35	10 nF	SMD	0603		
36	C39	22 $\mu$ F / 6.3 V	SMD	1206	AVX	12066D226KAT2A
37	C40	100 $\mu$ F / 6.3 V	SMD	1210	AVX	12104D107MAT2A
38	C41	4 $\mu$ F 7 / 50 V / X7R	SMD	1812	AVX	18125C475KAT2A
39	D1	SM6T39A	SMD	SMB	ST	SMA6T39A
40	D4	STPS2L40	SMD	SMB	ST	STPS2L40
41	D6	STPS2L40	SMD	SMB	ST	STPS2L40
42	D7	BAW56/SOT	SMD	SOT23		
43	D8	STPS1L40M	SMD	DO216-AA	ST	STPS1L40M
44	D9	STPS1L40M	SMD	DO216-AA	ST	STPS1L40M
45	D10	4.7 V	SMD	SOD80		
46	S1	Header 1 x 2	TH			
47	S2	Header 1 x 2	TH			
48	S3	Header 1 x 3	TH			
49	S4	Header 1 x 3	TH			
50	V <sub>I/O</sub> level	Header 2 x 5	TH			
51	V <sub>CORE</sub> level	Header 2 x 5	TH			
52	Skip	Header 2 x 3	TH			
53	J3	Jack - PCB	TH			
54	J14	Header 1 x 1	TH			
55	J15	Header 1 x 1	TH			
56	J16	Ind. Con. 2	TH		Ph. Con.	MSTBA 2,5 / 2-G-5,08
57	J17	Ind. Con. 4	TH		Ph. Con.	MSTBA 2,5 / 4-G-5,08
58	J18	Ind. Con. 6	TH		Ph. Con.	MSTBA 2,5 / 6-G-5,08
59	L1	33 $\mu$ H / 1.5 A	SMD		Coilcraft	MSS7341-333MLB
60	L2	33 $\mu$ H / 1.5 A	SMD		Coilcraft	MSS7341-333MLB
61	L3	5.0 $\mu$ H / 3 A	SMD		Coilcraft	MSS7341-502MLB
62	L4	3.8 $\mu$ H / 6 A	SMD		Coilcraft	MSS1038-382NLB
63	L5	1 $\mu$ H / 1 A	SMD		Coilcraft	ME3220-102MLB
64	Q1	STS4DNF60	SMD		ST	STS4DNF60L
65	Q2	STS7NF60L	SMD		ST	STS7NF60L
66	Q3	STS7NF60L	SMD		ST	STS7NF60L
67	R1	4.7 k $\Omega$	SMD	0603		

Table 7. Bill of materials (continued)

Item	Part	Description	Type	Size	Manufacturer	Part number
68	R2	36 k $\Omega$ / 1%	SMD	0603		
69	R3	200 k $\Omega$ / 1%	SMD	0603		
70	R4	10 k $\Omega$ / 1%	SMD	0603		
71	R5	4.7 k $\Omega$	SMD	0603		
72	R6	18 k $\Omega$ / 1%	SMD	0603		
73	R7	240 k $\Omega$ / 1%	SMD	0603		
74	R8	10 k $\Omega$ / 1%	SMD	0603		
75	R9	3.3 $\Omega$	SMD	0805		
76	R10	1.8 k $\Omega$	SMD	0603		
77	R11	560 $\Omega$	SMD	0603		
78	R110	4.7 k $\Omega$ / 1%	SMD	0603		
79	R19	1 k $\Omega$	SMD	0603		
80	R20	680 $\Omega$	SMD	0603		
81	R21	0 $\Omega$	SMD	0603		
82	R22	0 $\Omega$	SMD	0603		
83	R23	0 $\Omega$	SMD	0603		
84	R24	0 $\Omega$	SMD	0603		
85	R25	10 $\Omega$	SMD	0603		
86	R26	10 $\Omega$	SMD	0603		
87	R27	62 k $\Omega$	SMD	0603		
88	R28	10 k $\Omega$	SMD	0603		
89	R29	51 k $\Omega$	SMD	0603		
90	R31	10 k $\Omega$	SMD	0603		
91	R32	10 k $\Omega$	SMD	0603		
92	R34	10 k $\Omega$	SMD	0603		
93	R35	51 k $\Omega$	SMD	0603		
94	R36	51 k $\Omega$	SMD	0603		
95	R37	47 $\Omega$	SMD	0603		
96	R38	3.3 k $\Omega$	SMD	0603		
97	R39	3.3 k $\Omega$	SMD	0603		
98	R40	100 k $\Omega$	SMD	0603		
99	R41	51 k $\Omega$	SMD	0603		
100	R42	51 k $\Omega$	SMD	0603		
101	R101	1 k $\Omega$ / 1%	SMD	0603		
102	R102	2 k $\Omega$ / 1%	SMD	0603		

Table 7. Bill of materials (continued)

Item	Part	Description	Type	Size	Manufacturer	Part number
103	R103	3 k $\Omega$ / 1%	SMD	0603		
104	R104	3 k $\Omega$ / 1%	SMD	0603		
105	R105	200 $\Omega$ / 1%	SMD	0603		
106	R106	6.8 k $\Omega$ / 1%	SMD	0603		
107	R107	9.1 k $\Omega$ / 1%	SMD	0603		
108	R108	820 k $\Omega$ / 1%	SMD	0603		
109	R109	3.3 k $\Omega$ / 1%	SMD	0603		
110	R201	1 k $\Omega$ / 1%	SMD	0603		
111	R202	2 k $\Omega$ / 1%	SMD	0603		
112	R203	3 k $\Omega$ / 1%	SMD	0603		
113	R204	3 k $\Omega$ / 1%	SMD	0603		
114	R205	200 $\Omega$ / 1%	SMD	0603		
115	R206	6.8 k $\Omega$ / 1%	SMD	0603		
116	R207	9.1 k $\Omega$ / 1%	SMD	0603		
117	R208	820 k $\Omega$ / 1%	SMD	0603		
118	R209	51 k $\Omega$	SMD	0603		
119	U1	L5970AD	SMD	SO-8	ST	L5970AD
120	U2	LK112_33	SMD	SOT23-5	ST	LK112M33TR
121	U3	L5970AD	SMD	SO-8	ST	L5970AD
122	U4	KF25_SOIC8	SMD	SO-8	ST	KF25BD-TR
123	U5	PM6680A	SMD	VFQFPN-32 5X5	ST	PM6680A
124	U6	STM6719TEWB6F	SMD	SOT23-6	ST	STM6719TGWB6F

## 6 Measurements

The performance and properties of each part of the board is indicated in the measurements below. These measurements were performed for the PM6680A and L5971AD blocks independently.

### 6.1 PM6680A block - measurements

The performance measurements of the PM6680A part focus mainly on efficiency, light load consumption, output ripple and transients.

#### 6.1.1 Efficiency and light load consumption modes

Since the device consists of three power parts (two controllers and one LDO) it makes sense to measure total efficiency. [Figure 17](#) displays how efficiency depends on input voltage level at full load output ( $V_{CORE} 2.5 V / 4 A$ ,  $V_{I/O} 3.3 V / 2 A$ ).

**Figure 17. Efficiency of the dual step-down converter at full load**

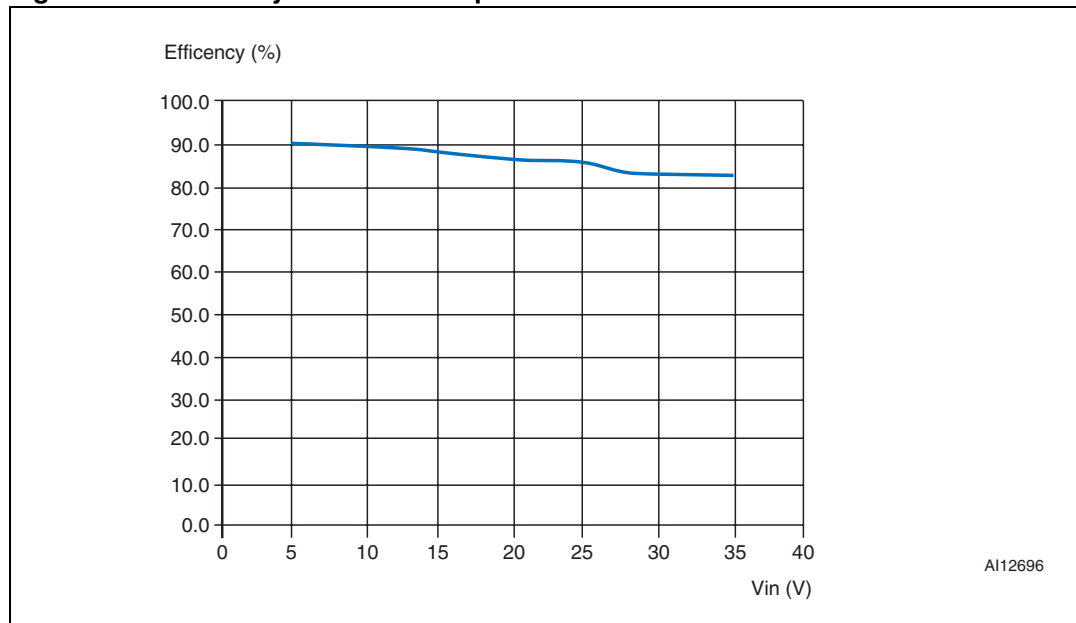

The efficiency is in the range of 83 - 91%. It should be noted that the total efficiency strictly depends on the performance of each component. The System Supply board was designed to satisfy a wide input voltage range. Therefore, 60 V MOSFETS are used on the board. If the input voltage of the end application is less (up to 30 V for instance), efficiency can be improved by using lower  $R_{DS(ON)}$  30 V MOSFETS in the same package. The expected efficiency gain is about 3 - 4%.

The PM6680A can work in several modes with regard to light load. These options are mainly used for battery applications where relatively high consumption at light load can drain the battery even when no power is requested. The PM6680A allows three modes (see [3.0.2](#)): PWM, No Audible Noise and Skip. [Figure 18](#) shows the consumption of the board for different modes of the PM6680A. There is no load on the output and other parts of the SMPS are disabled.

**Figure 18. PM6680A consumption at no load condition, in the different modes**

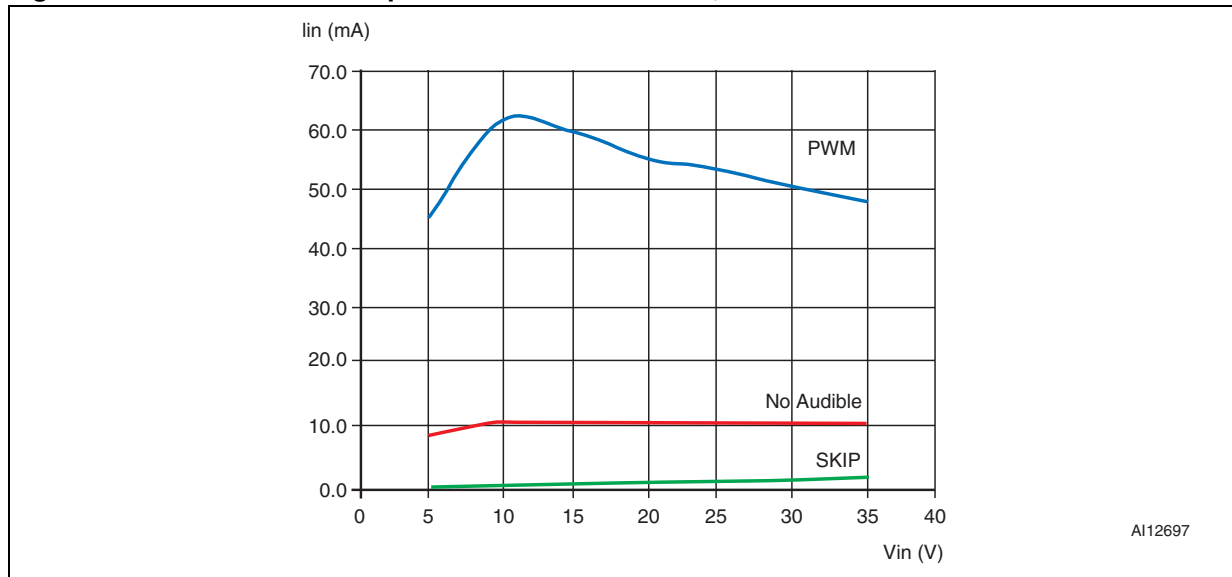

In analyzing the data in [Figure 18](#), it should be noted that the consumption is slightly increased by several passive components which generate inhibit of the L5970ADs. Total consumption of these parts at 35 V on the input is about 1.5 mA. This is not compensated for in the chart in [Figure 18](#). It is possible to see the effect of the different operating modes of the converter by observing the output ripple voltage waveforms in [Figure 19](#). These measurements are made under the following conditions: V<sub>CORE</sub> output set to 2.5 V, no load, at 12 V on the input.

**Figure 19. Output voltage ripple in different modes of light load operation**

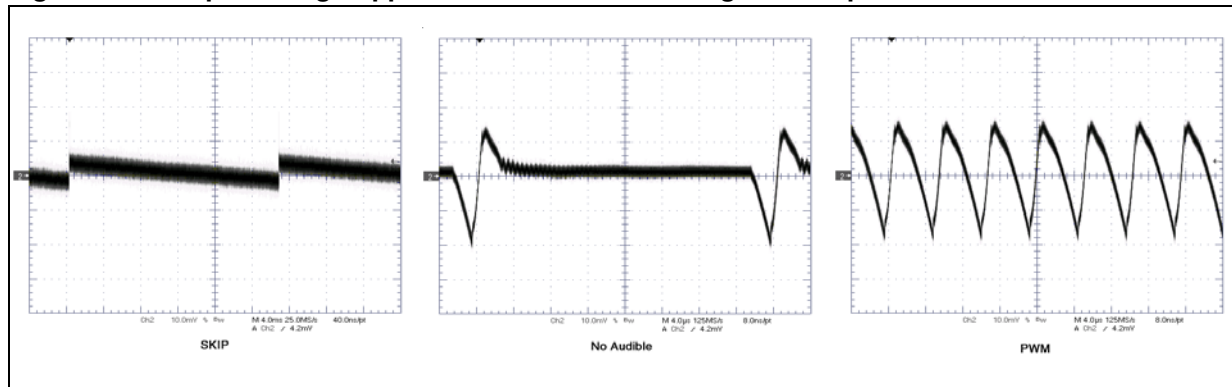

### 6.1.2 Output voltage ripple

Output voltage ripple depends on the current ripple flowing through the choke. The current ripple depends on the input and output voltage levels. Therefore, it is mandatory to measure the output voltage ripple for different input and output voltage conditions. [Figure 20](#) shows the output voltage ripple of V<sub>CORE</sub> at the minimum input voltage (5 V), while [Figure 21](#) displays the output voltage ripple of V<sub>CORE</sub> at the maximum output voltage (36 V). [Figure 22](#) shows the output voltage ripple of V<sub>I/O</sub> at the minimum input voltage (5 V), and [Figure 20](#) displays the output voltage ripple of V<sub>I/O</sub> at the maximum input voltage (36 V). All of the figures represent the minimum and maximum output voltages at maximum load (0.9 V and 2.5 V at 4 A for V<sub>CORE</sub>, and 1 V and 3.3 V at 2 A for V<sub>I/O</sub>).



Figure 20. Output voltage ripple of  $V_{CORE}$  at the minimum input voltage (5 V)

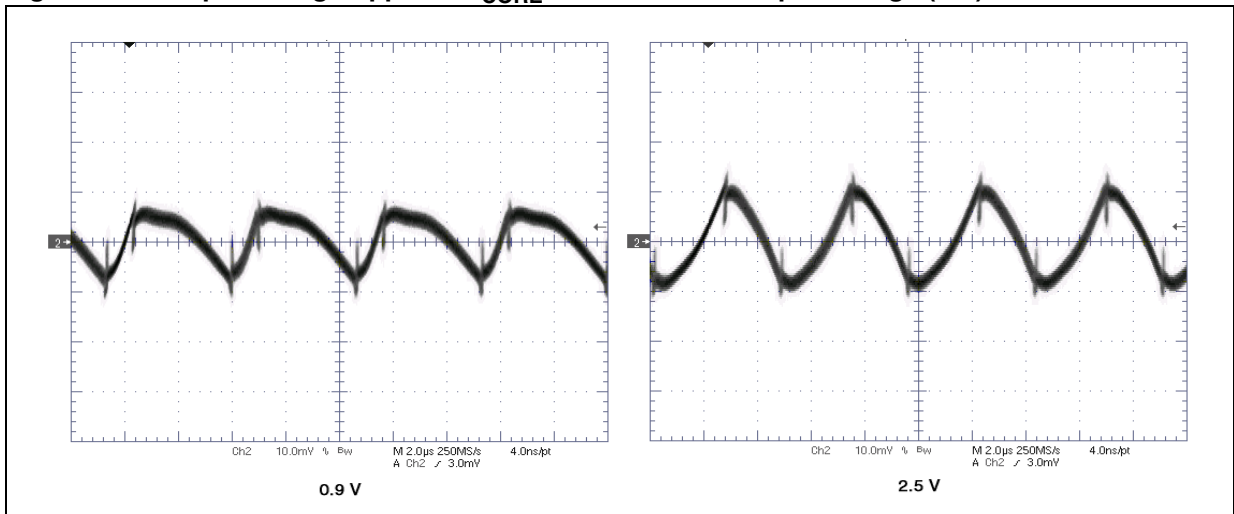

Figure 21. Output voltage ripple of  $V_{CORE}$  at the maximum output voltage (36 V)

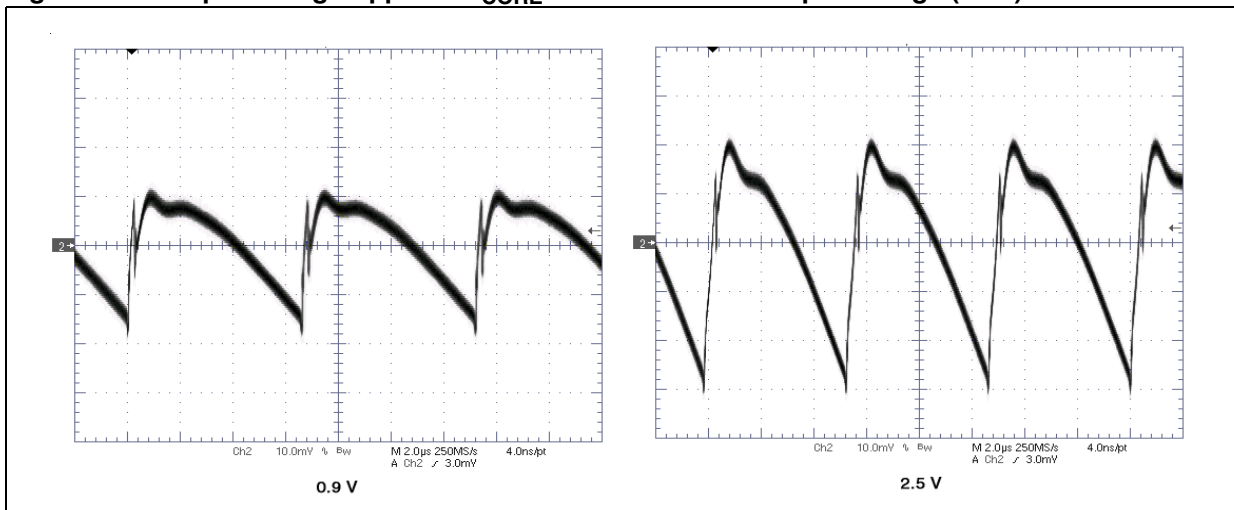

Figure 22. Output voltage ripple of  $V_{IO}$  at the minimum input voltage (5 V)

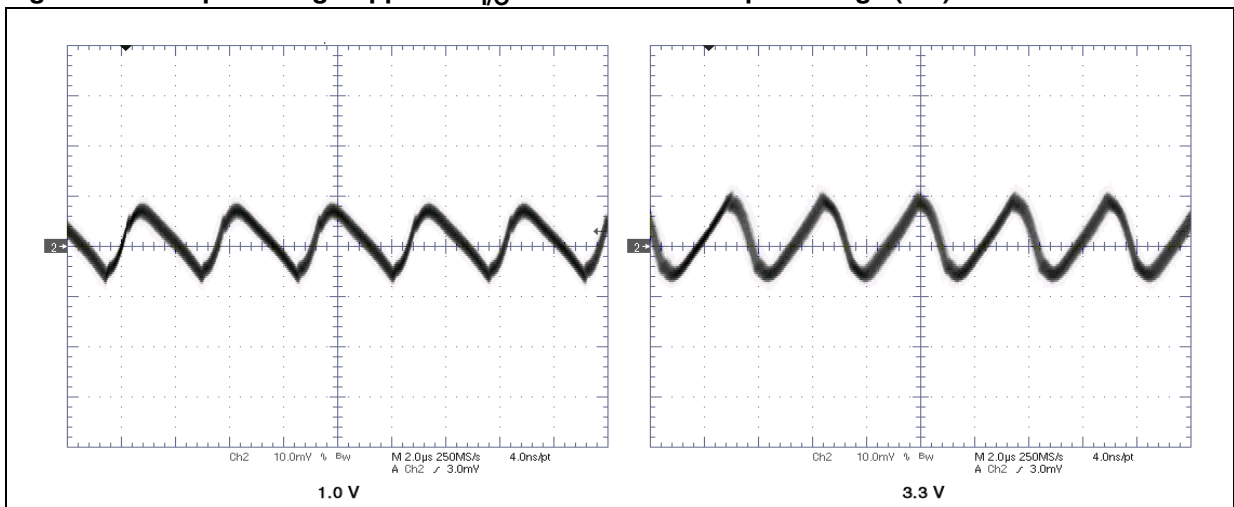

Figure 23. Output voltage ripple of  $V_{I/O}$  at the maximum input voltage (36 V)

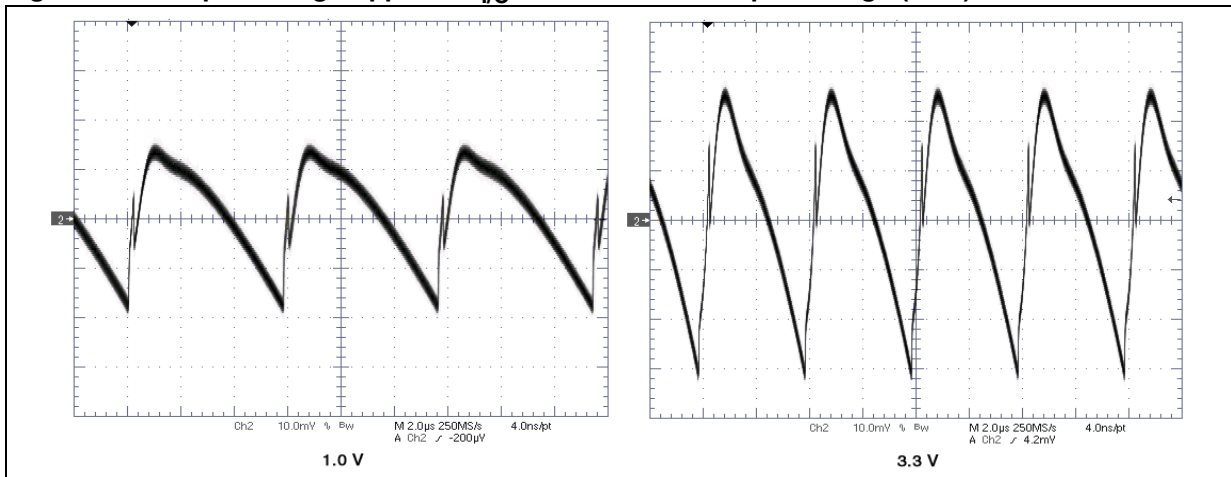

Figure 24. Start-up without setting the sequence

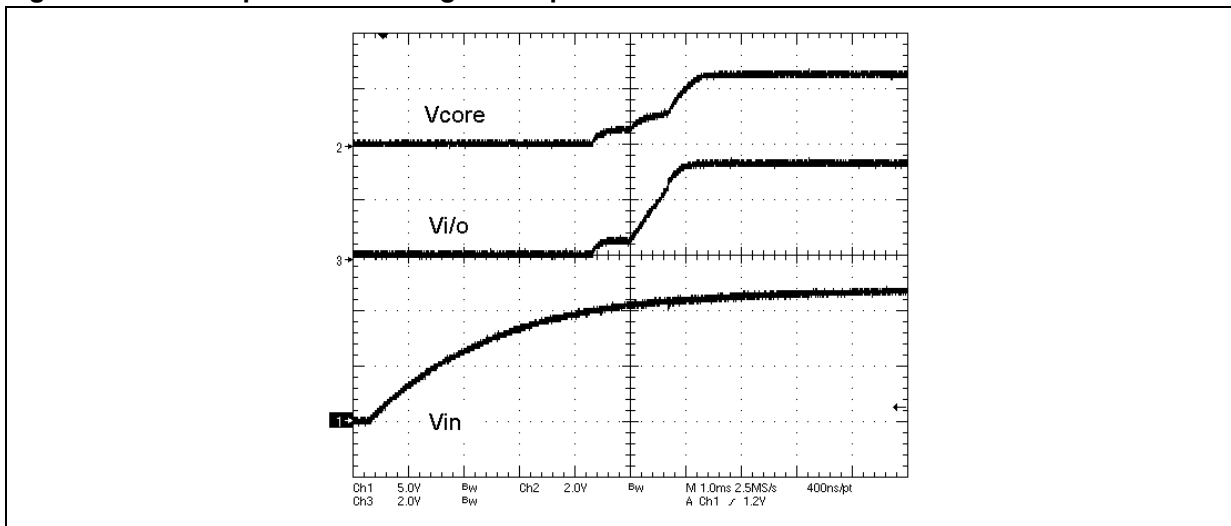
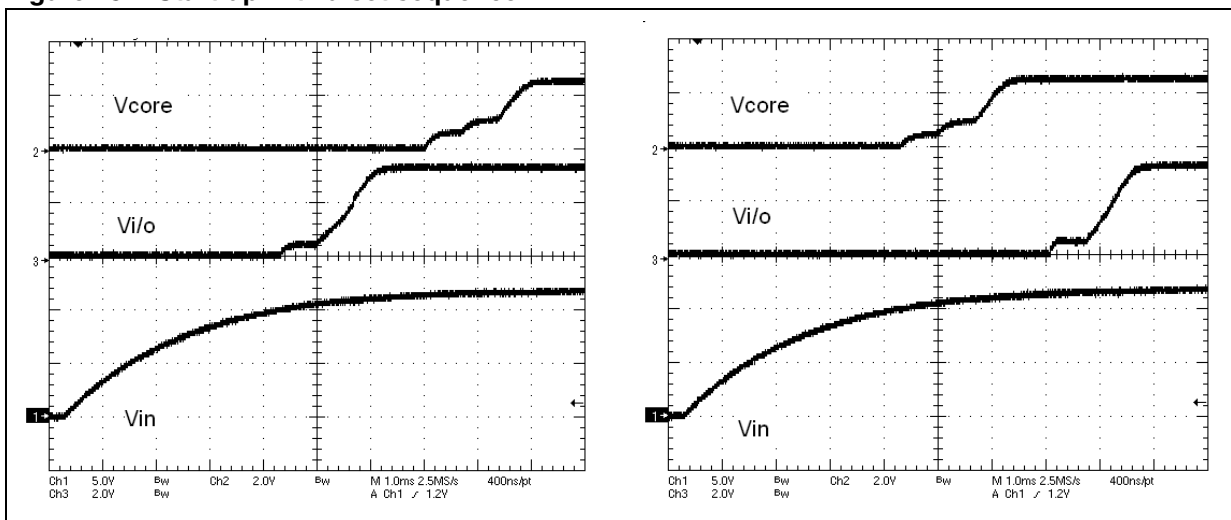

Figure 25. Start-up with a set sequence



### 6.1.3 Start-up sequence

The correct start-up sequence of the supply voltage is typically requested by the FPGA device. Therefore, there it is possible to set a dedicated start-up sequence on the System Supply board (see 3.0.2. Figure 24) shows the start-up sequence waveform of  $V_{CORE}$  and  $V_{I/O}$  outputs when the jumpers described in Table 2 are set in accordance with line 3 in the table.

The waveforms shown in Figure 25 illustrate different start-up sequences in accordance with the jumper settings displayed in Table 2, lines 4 and 5.

### 6.1.4 Transient response

Transient response refers to the behavior of the output voltage when the load changes fast. This test was also performed on the outputs of the PM6680A branch. The load was changed between maximum and zero load ( $0 \leftrightarrow 2$  A on  $V_{I/O}$  output and  $0 \leftrightarrow 4$  A on the  $V_{CORE}$  output). The input voltage was 12 V and output voltage was 3.3 V and 2.5 V, respectively. The repetition of load change was 500 Hz. The results of the measurements are shown in Figure 26 and Figure 27. The voltage spikes caused by increasing the load are quite low. It is possible to observe that the converter reacts very fast to a rising load and the undervoltage is small (left waveform in figures). If the load is decreasing fast the overvoltage spikes appear on the output (right side of picture). This effect depends partly on the reaction of the controller and partly on the parameters of the output filter. There is remaining energy stored in the inductor and if the load decreases this energy should be stored in the output capacitor. This effect can be reduced by either reducing the value of the inductor (to reduce the amount of energy stored in the inductor), or by increasing the value of the output capacitor (a higher capacitance is capable of absorbing more energy from the inductor).

Figure 26. Load transient response on  $V_{CORE}$  output

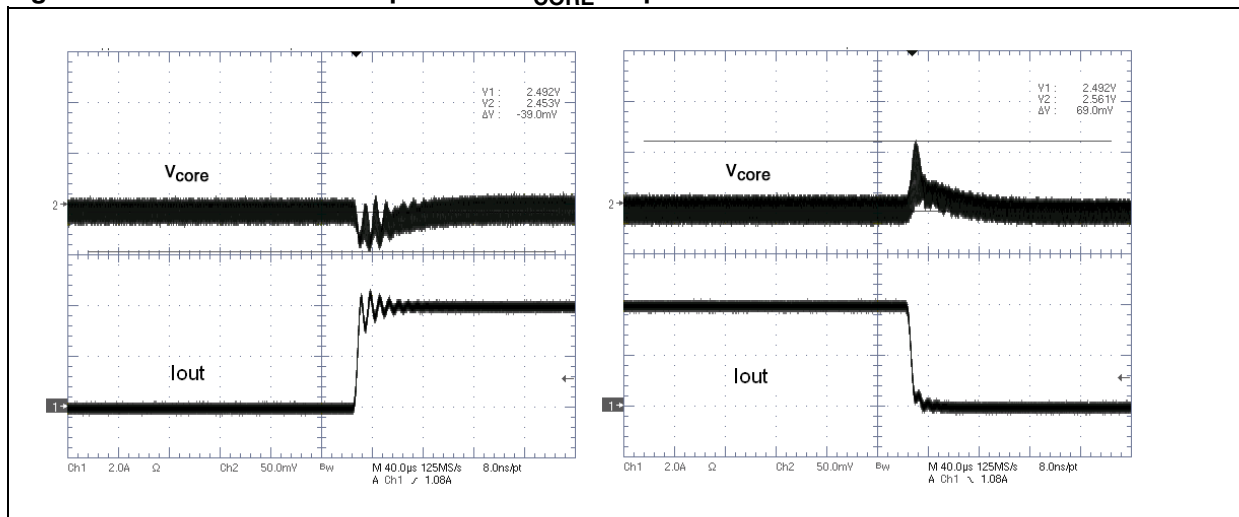
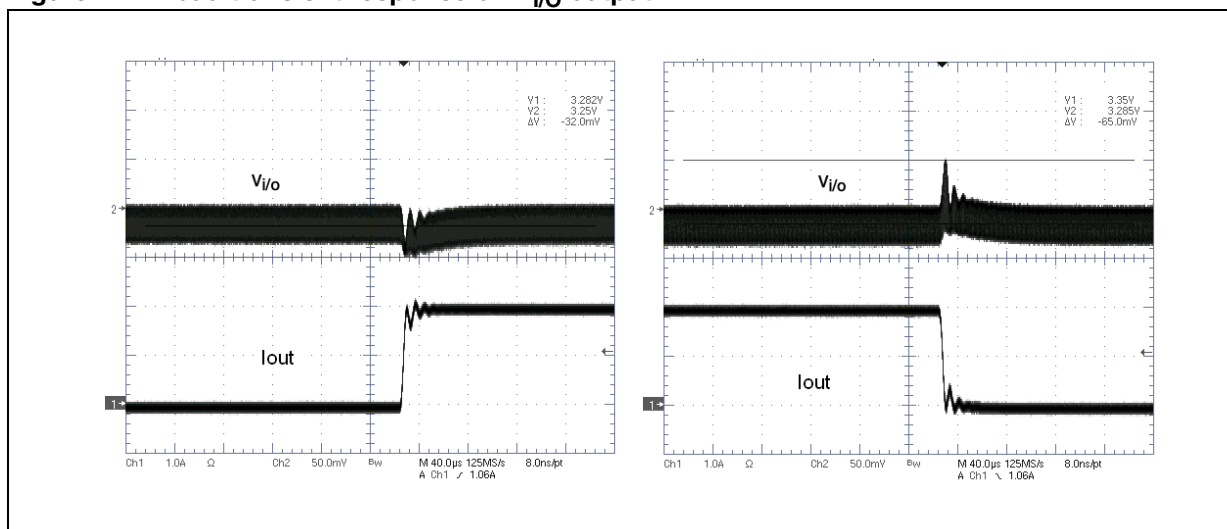

Figure 27. Load transient response on  $V_{I/O}$  output



## 6.2 L5970AD blocks - measurements

### 6.2.1 Efficiency

The L5970AD is a powerful converter with very good performance and efficiency. Because a diode is used as a low side switch, however, the efficiency is a slightly less compared to a synchronous converter such as the PM6680A. Theoretically, the efficiency declines when output voltage is decreasing and input voltage is increasing. [Figure 28](#) displays the efficiency of Output 3, depending on the input voltage at full load (800 mA). [Figure 29](#) displays the same measurement for the Analog output. The efficiency of the Analog output is better thanks to the higher output voltage level. The efficiency of the Analog output voltage was measured in a range of 7 - 35 V. It should be noted that the output voltage is 5 V, so the device does not work as a switching converter in cases where the input and output voltage are similar or lower than the required output. In this case the L5973AD works with 100% duty cycle.

**Figure 28. Efficiency of output 3, by input voltage level**

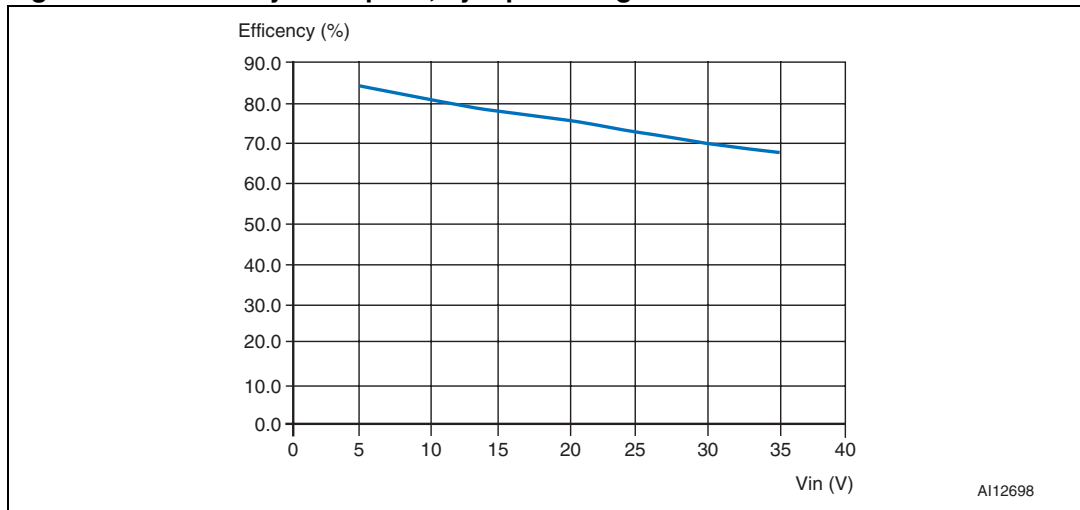
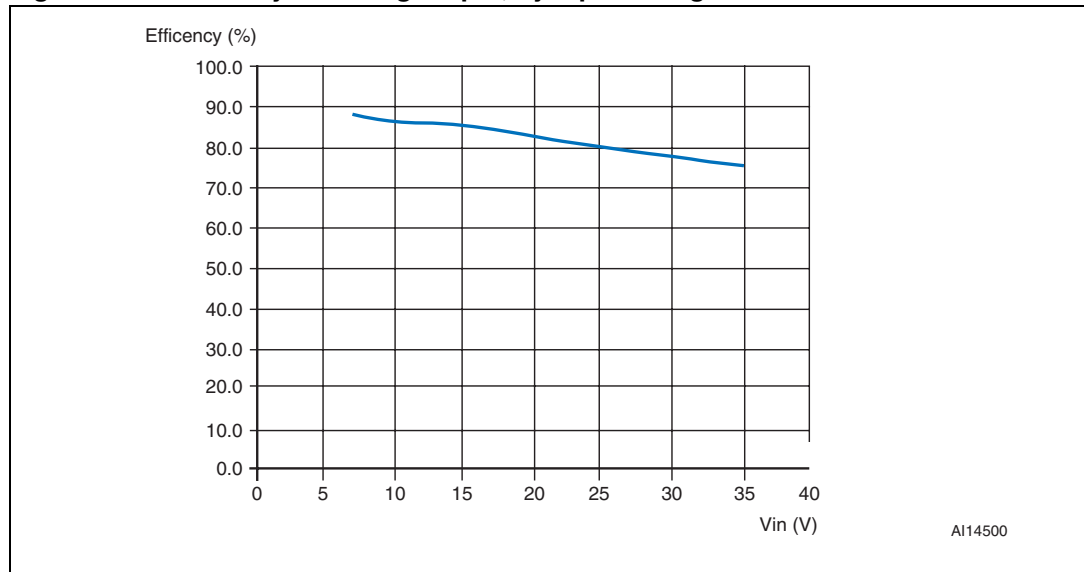

Figure 29. Efficiency of analog output, by input voltage level



### 6.2.2 Output voltage ripple

The output voltage ripple of the switching parts of the Analog and  $V_{SYS}$  outputs are shown in [Figure 30](#) and [Figure 31](#). The measurements were made for different input voltages, because the current ripple influence on the output voltage ripple depends on the input voltage level. The output voltage ripple on the 3.3 V Analog output and the  $V_{AUX}$  output are displayed in [Figure 32](#) and [Figure 33](#). As these outputs are generated by LDOs, the output voltage ripple is the same (independent) for all input voltages, and is very low. Therefore, only one output voltage ripple image is shown in the figures 32 and 33. All of the measurements were taken at full output load.

Figure 30. Analog 5 V - output voltage ripple

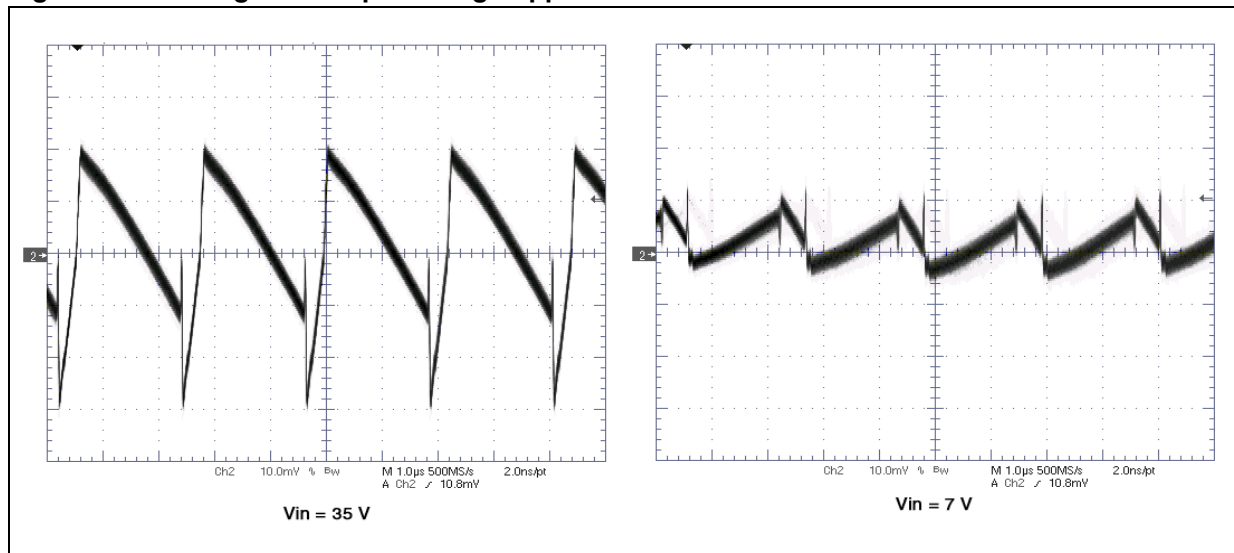
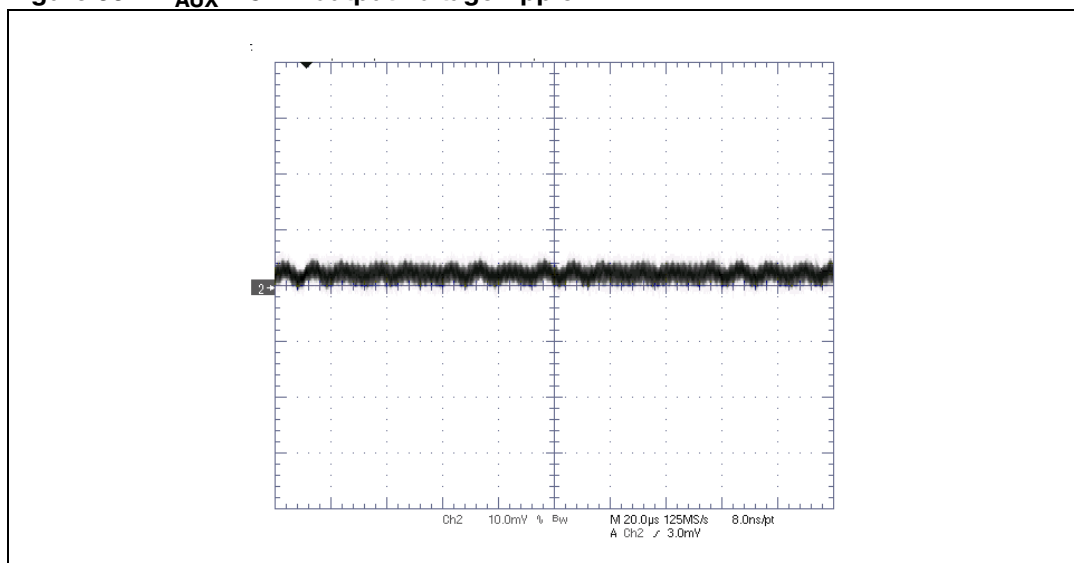



Figure 33.  $V_{AUX}$  2.5 V - output voltage ripple





### 6.2.3 Transient

Transient responses were measured only for  $V_{AUX}$  and  $V_{SYS}$ . The transient responses are displayed in [Figure 34](#) and [Figure 35](#). The transient waveforms of the L5970AD section show the response time. The most visible difference between the L5970AD in classic voltage mode and the PM6680A working in Constant On Time mode is the reaction when there is a fast load increase. Whereas the PM6680A reacts as fast as possible on the rising load, the L5970AD will wait short time as the compensation network is implemented in feedback loop (see [Figure 24](#) and [Figure 25](#)).

**Figure 34. Transient response of  $V_{SYS}$  based on the L5970AD**

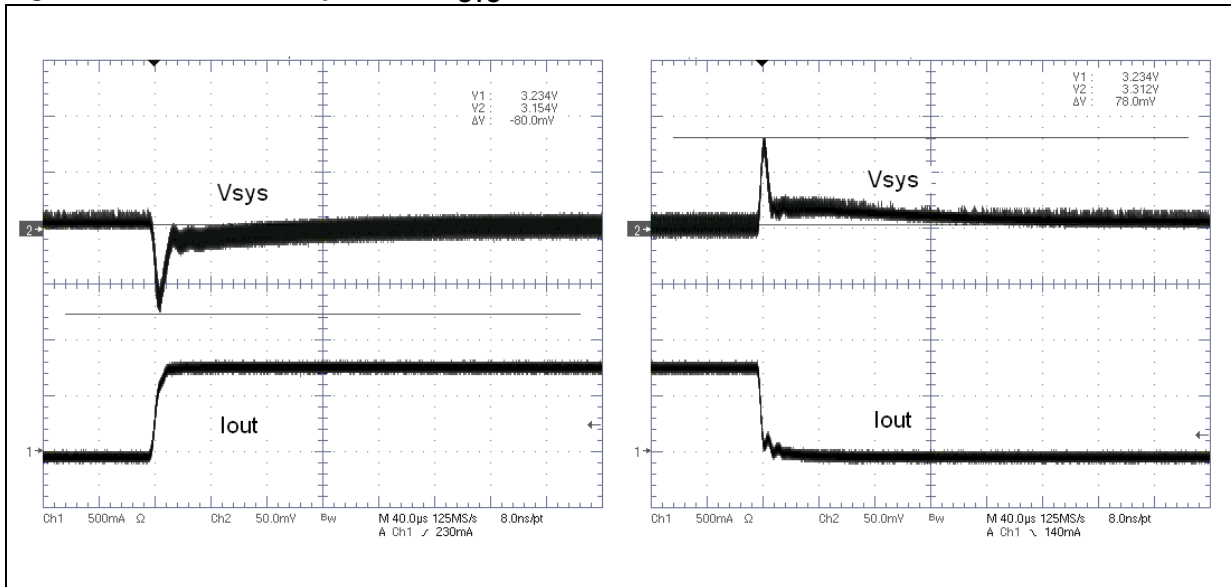

**Figure 35. Transient response of  $V_{AUX}$  generated by the LDO KF25**

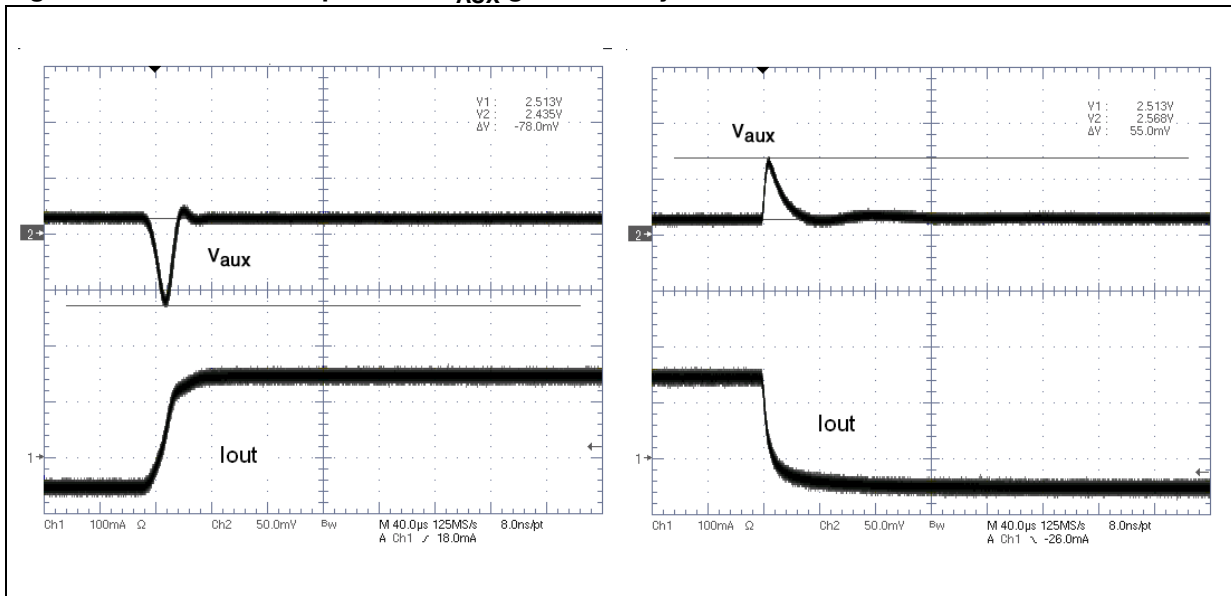

## 7 References

1. Datasheet PM6680A
2. Datasheet L5970AD
3. Datasheet LK112
4. Datasheet KF25
5. STM6719
6. AN1330 - designing with the L5970D, 1 A high efficiency DC-DC converter.

## 8 Revision history

**Table 8. Document revision history**

Date	Revision	Changes
25-Sep-2007	1	Initial release

**Please Read Carefully:**

Information in this document is provided solely in connection with ST products. STMicroelectronics NV and its subsidiaries ("ST") reserve the right to make changes, corrections, modifications or improvements, to this document, and the products and services described herein at any time, without notice.

All ST products are sold pursuant to ST's terms and conditions of sale.

Purchasers are solely responsible for the choice, selection and use of the ST products and services described herein, and ST assumes no liability whatsoever relating to the choice, selection or use of the ST products and services described herein.

No license, express or implied, by estoppel or otherwise, to any intellectual property rights is granted under this document. If any part of this document refers to any third party products or services it shall not be deemed a license grant by ST for the use of such third party products or services, or any intellectual property contained therein or considered as a warranty covering the use in any manner whatsoever of such third party products or services or any intellectual property contained therein.

**UNLESS OTHERWISE SET FORTH IN ST'S TERMS AND CONDITIONS OF SALE ST DISCLAIMS ANY EXPRESS OR IMPLIED WARRANTY WITH RESPECT TO THE USE AND/OR SALE OF ST PRODUCTS INCLUDING WITHOUT LIMITATION IMPLIED WARRANTIES OF MERCHANTABILITY, FITNESS FOR A PARTICULAR PURPOSE (AND THEIR EQUIVALENTS UNDER THE LAWS OF ANY JURISDICTION), OR INFRINGEMENT OF ANY PATENT, COPYRIGHT OR OTHER INTELLECTUAL PROPERTY RIGHT.**

**UNLESS EXPRESSLY APPROVED IN WRITING BY AN AUTHORIZED ST REPRESENTATIVE, ST PRODUCTS ARE NOT RECOMMENDED, AUTHORIZED OR WARRANTED FOR USE IN MILITARY, AIR CRAFT, SPACE, LIFE SAVING, OR LIFE SUSTAINING APPLICATIONS, NOR IN PRODUCTS OR SYSTEMS WHERE FAILURE OR MALFUNCTION MAY RESULT IN PERSONAL INJURY, DEATH, OR SEVERE PROPERTY OR ENVIRONMENTAL DAMAGE. ST PRODUCTS WHICH ARE NOT SPECIFIED AS "AUTOMOTIVE GRADE" MAY ONLY BE USED IN AUTOMOTIVE APPLICATIONS AT USER'S OWN RISK.**

Resale of ST products with provisions different from the statements and/or technical features set forth in this document shall immediately void any warranty granted by ST for the ST product or service described herein and shall not create or extend in any manner whatsoever, any liability of ST.

ST and the ST logo are trademarks or registered trademarks of ST in various countries.

Information in this document supersedes and replaces all information previously supplied.

The ST logo is a registered trademark of STMicroelectronics. All other names are the property of their respective owners.

© 2007 STMicroelectronics - All rights reserved

STMicroelectronics group of companies

Australia - Belgium - Brazil - Canada - China - Czech Republic - Finland - France - Germany - Hong Kong - India - Israel - Italy - Japan - Malaysia - Malta - Morocco - Singapore - Spain - Sweden - Switzerland - United Kingdom - United States of America

[www.st.com](http://www.st.com)