



PCA8576F

Automotive LCD driver for low multiplex rates

Rev. 1 — 22 November 2013

Product data sheet

1. General description

The PCA8576F is a peripheral device which interfaces to almost any Liquid Crystal Display (LCD)¹ with low multiplex rates. It generates the drive signals for any static or multiplexed LCD containing up to four backplanes and up to 40 segments. It can be easily cascaded for larger LCD applications. The PCA8576F is compatible with most microcontrollers and communicates via the two-line bidirectional I²C-bus. Communication overheads are minimized by a display RAM with auto-incremented addressing, by hardware subaddressing and by display memory switching (static and duplex drive modes).

For a selection of NXP LCD segment drivers, see [Table 28 on page 47](#).

2. Features and benefits

- AEC-Q100 grade 2 compliant for automotive applications
- Single chip LCD controller and driver
- Selectable backplane drive configuration: static or 2, 3, 4 backplane multiplexing
- Selectable display bias configuration: static, $\frac{1}{2}$, or $\frac{1}{3}$
- Internal LCD bias generation with voltage-follower buffers
- 40 segment drives:
 - ◆ Up to 20 7-segment numeric characters
 - ◆ Up to 10 14-segment alphanumeric characters
 - ◆ Any graphics of up to 160 elements
- 40 × 4-bit RAM for display data storage
- Auto-incremented display data loading across device subaddress boundaries
- Display memory bank switching in static and duplex drive modes
- Versatile blinking modes
- Independent supplies possible for LCD and logic voltages
- Wide power supply range: from 1.8 V to 5.5 V
- Wide LCD supply range:
 - ◆ From 2.5 V for low-threshold LCDs
 - ◆ Up to 8.0 V for high-threshold twisted nematic LCDs
- Low power consumption
- 400 kHz I²C-bus interface
- May be cascaded for large LCD applications (up to 2560 elements possible)
- No external components required
- Compatible with chip-on-glass and chip-on-board technology

1. The definition of the abbreviations and acronyms used in this data sheet can be found in [Section 19](#).



- Manufactured in silicon gate CMOS process

3. Ordering information

Table 1. Ordering information

Type number	Package		
	Name	Description	Version
PCA8576FUG	bare die	59 bumps	PCA8576FUG

3.1 Ordering options

Table 2. Ordering options

Product type number	Sales item (12NC)	Orderable part number	IC revision	Delivery form
PCA8576FUG/2DA/Q1	935302565026	PCA8576FUG/2DA/QKP	1	chips in tray

4. Marking

Table 3. Marking codes

Product type number	Marking code
PCA8576FUG/2DA/Q1	PC8576F-1

5. Block diagram

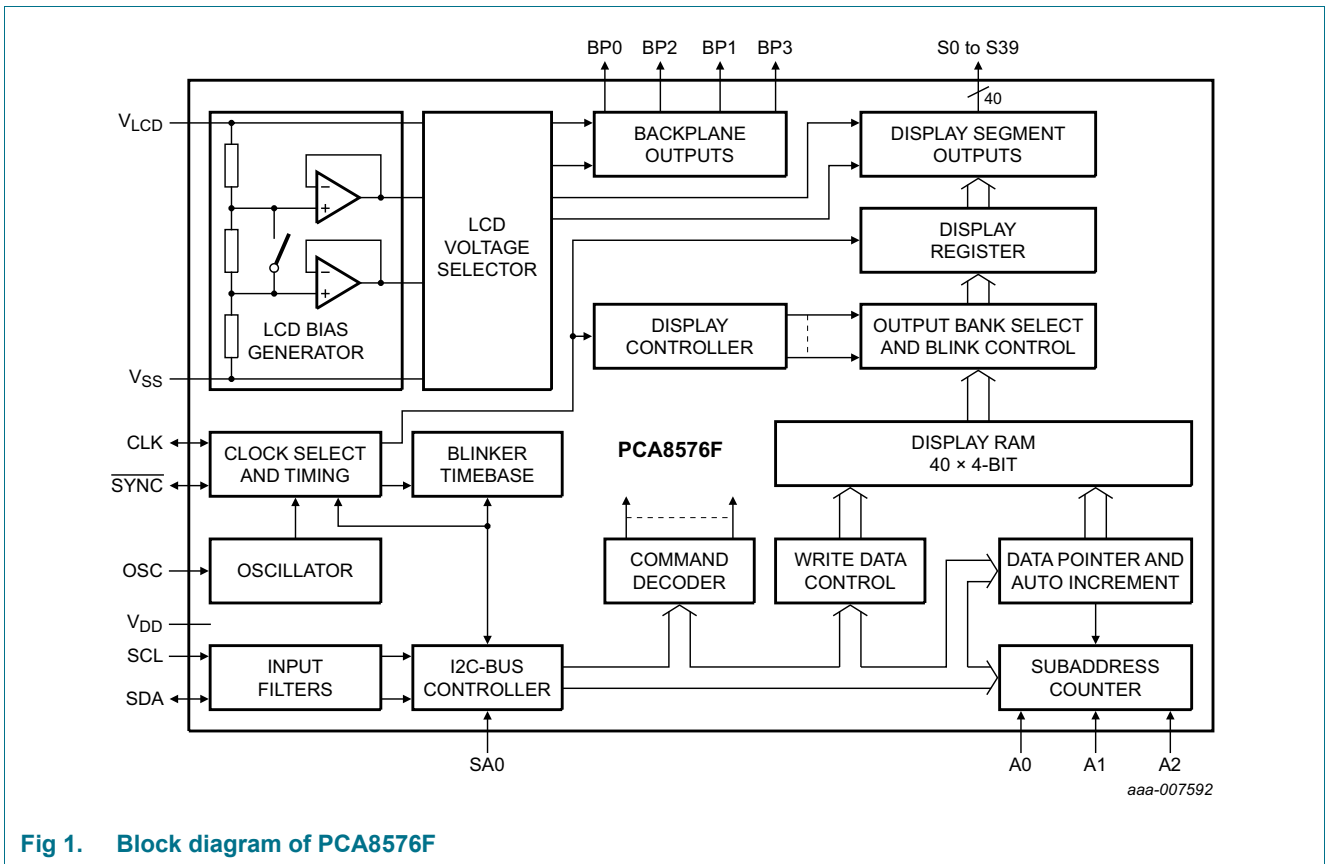
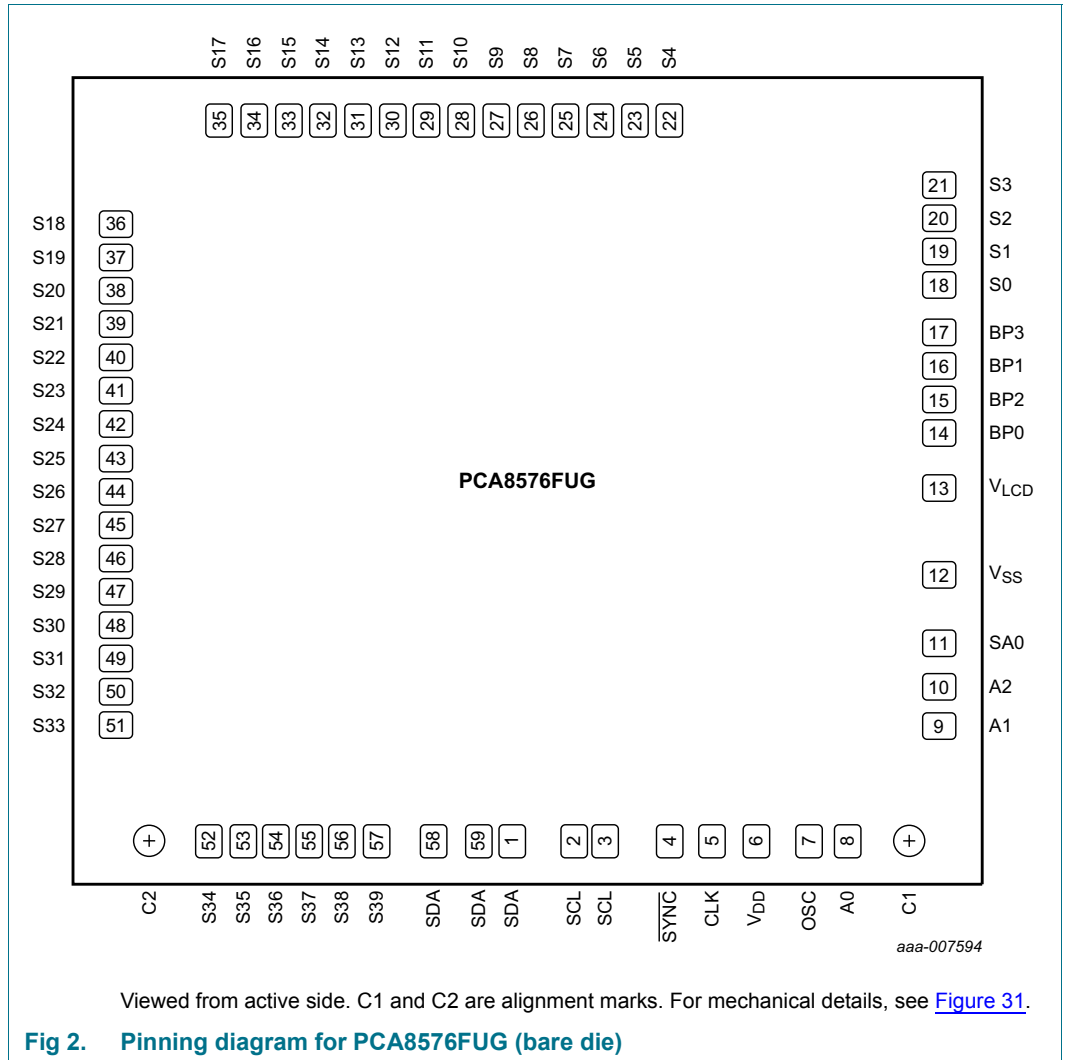

Fig 1. Block diagram of PCA8576F

6. Pinning information

6.1 Pinning



Viewed from active side. C1 and C2 are alignment marks. For mechanical details, see [Figure 31](#).

Fig 2. Pinning diagram for PCA8576FUG (bare die)

6.2 Pin description

Table 4. Pin description

Input or input/output pins must always be at a defined level (V_{SS} or V_{DD}) unless otherwise specified.

Symbol	Pin	Description
SDA	1, 58, 59	I ² C-bus serial data input and output
SCL	2, 3	I ² C-bus serial clock input
CLK	5	external clock input or output
V_{DD}	6	supply voltage
$\overline{\text{SYNC}}$	4	cascade synchronization input or output; if not used it must be left open
OSC	7	internal oscillator enable input
A0 to A2	8 to 10	subaddress inputs
SA0	11	I ² C-bus address input; bit 0
V_{SS}	12 ^[1]	ground supply voltage
V_{LCD}	13	LCD supply voltage
BP0, BP2, BP1, BP3	14 to 17	LCD backplane outputs
S0 to S39	18 to 57	LCD segment outputs

[1] The substrate (rear side of the die) is connected to V_{SS} and should be electrically isolated.

7. Functional description

7.1 Commands of PCA8576F

The commands available to the PCA8576F are defined in [Table 5](#).

Table 5. Definition of PCA8576F commands

Command	Operation code								Reference	
	7	6	5	4	3	2	1	0		
mode-set	C	1	0	-[1]	E	B	M[1:0]		Table 7	
load-data-pointer	C	0	P[5:0]							Table 8
device-select	C	1	1	0	0	A[2:0]			Table 9	
bank-select	C	1	1	1	1	0	I	O	Table 10	
blink-select	C	1	1	1	0	AB	BF[1:0]		Table 11	

[1] Not used.

All available commands carry a continuation bit C in their most significant bit position as shown in [Figure 3](#).

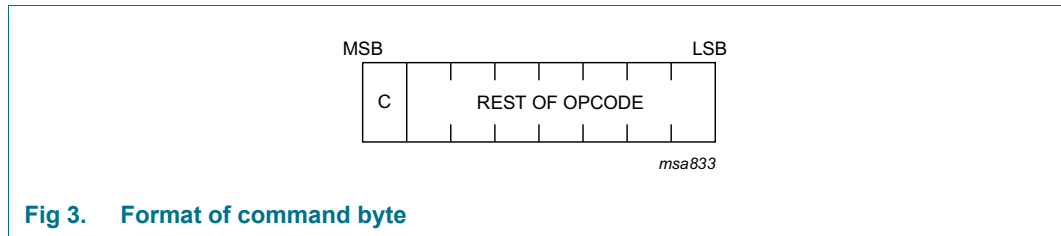

Fig 3. Format of command byte

When this bit is set logic 1, it indicates that the next byte of the transfer to arrive will also represent a command. If this bit is set logic 0, it indicates that the command byte is the last in the transfer. Further bytes will be regarded as display data (see [Table 6](#)).

Table 6. C bit description

Bit	Symbol	Value	Description
7	C		continue bit
		0	last control byte in the transfer; next byte will be regarded as display data
		1	control bytes continue; next byte will be a command too

7.1.1 Command: mode-set

Table 7. Mode-set command bit description

Bit	Symbol	Value	Description
7	C	0, 1	see Table 6
6, 5	-	10	fixed value
4	-	-	unused
3	E		display status ^[1]
		0	disabled (blank) ^[2]
		1	enabled

Table 7. Mode-set command bit description ...continued

Bit	Symbol	Value	Description
2	B		LCD bias configuration ^[3]
		0	1/3 bias
		1	1/2 bias
1 to 0	M[1:0]		LCD drive mode selection
		01	static; BP0
		10	1:2 multiplex; BP0, BP1
		11	1:3 multiplex; BP0, BP1, BP2
		00	1:4 multiplex; BP0, BP1, BP2, BP3

[1] The possibility to disable the display allows implementation of blinking under external control.

[2] The display is disabled by setting all backplane and segment outputs to V_{LCD} .

[3] Not applicable for static drive mode.

7.1.2 Command: load-data-pointer

Table 8. Load-data-pointer command bit description

See [Section 7.9.5](#).

Bit	Symbol	Value	Description
7	C	0, 1	see Table 6
6	-	0	fixed value
5 to 0	P[5:0]	000000 to 100111	6 bit binary value, 0 to 39; transferred to the data pointer to define one of forty display RAM addresses

7.1.3 Command: device-select

Table 9. Device-select command bit description

See [Section 7.9.6](#).

Bit	Symbol	Value	Description
7	C	0, 1	see Table 6
6 to 3	-	1100	fixed value
2 to 0	A[2:0]	000 to 111	3 bit binary value, 0 to 7; transferred to the subaddress counter to define one of eight hardware subaddresses

7.1.4 Command: bank-select

Table 10. Bank-select command bit description

See [Section 7.9.8.2](#) and [Section 7.9.8.3](#).

Bit	Symbol	Value	Description	
			Static	1:2 multiplex ^[1]
7	C	0, 1	see Table 6	
6 to 2	-	11110	fixed value	
1	I		input bank selection ; storage of arriving display data	
		0	RAM row 0	RAM rows 0 and 1
		1	RAM row 2	RAM rows 2 and 3
0	O		output bank selection ; retrieval of LCD display data	
		0	RAM row 0	RAM rows 0 and 1
		1	RAM row 2	RAM rows 2 and 3

[1] The bank-select command has no effect in 1:3 and 1:4 multiplex drive modes.

7.1.5 Command: blink-select

Table 11. Blink-select command bit description

See [Section 7.10](#).

Bit	Symbol	Value	Description
7	C	0, 1	see Table 6
6 to 3	-	1110	fixed value
2	AB		blink mode selection
		0	normal blinking ^[1]
		1	alternate RAM bank blinking ^[2]
1 to 0	BF[1:0]		blink frequency selection
		00	off
		01	1
		10	2
		11	3

[1] Normal blinking is assumed when the LCD multiplex drive modes 1:3 or 1:4 are selected.

[2] Alternate RAM bank blinking does not apply in 1:3 and 1:4 multiplex drive modes.

7.2 Initialization

At power-on the status of the I²C-bus and the registers of the PCA8576F is undefined. Therefore the PCA8576F should be initialized as quickly as possible after power-on to ensure a proper bus communication and to avoid display artifacts. The following instructions should be accomplished for initialization:

- I²C-bus initialization (only necessary if no communication with another I²C device on the bus has already taken place). For information about the I²C-bus, see [Section 8](#).
 - generating a START condition
 - sending 0h and ignoring the acknowledge
 - generating a STOP condition

- Mode-set command (see [Table 7](#)), setting
 - bit E = 0
 - bit B to the required LCD bias configuration
 - bits M[1:0] to the required LCD drive mode
- Load-data-pointer command (see [Table 8](#)), setting
 - bits P[5:0] to 0h (or any other required address)
- Device-select command (see [Table 9](#)), setting
 - bits A[2:0] to the required hardware subaddress (for example, 0h)
- Bank-select command (see [Table 10](#)), setting
 - bit I to 0
 - bit O to 0
- Blink-select command (see [Table 11](#)), setting
 - bit AB to 0 or 1
 - bits BF[1:0] to 00 (or to a desired blinking mode)
- writing meaningful information (for example, a logo) into the display RAM

After the initialization, the display can be switched on by setting bit E = 1 with the mode-set command.

7.3 Possible display configurations

The possible display configurations of the PCA8576F depend on the number of active backplane outputs required. A selection of display configurations is shown in [Table 12](#). All of these configurations can be implemented in the typical system shown in [Figure 5](#).

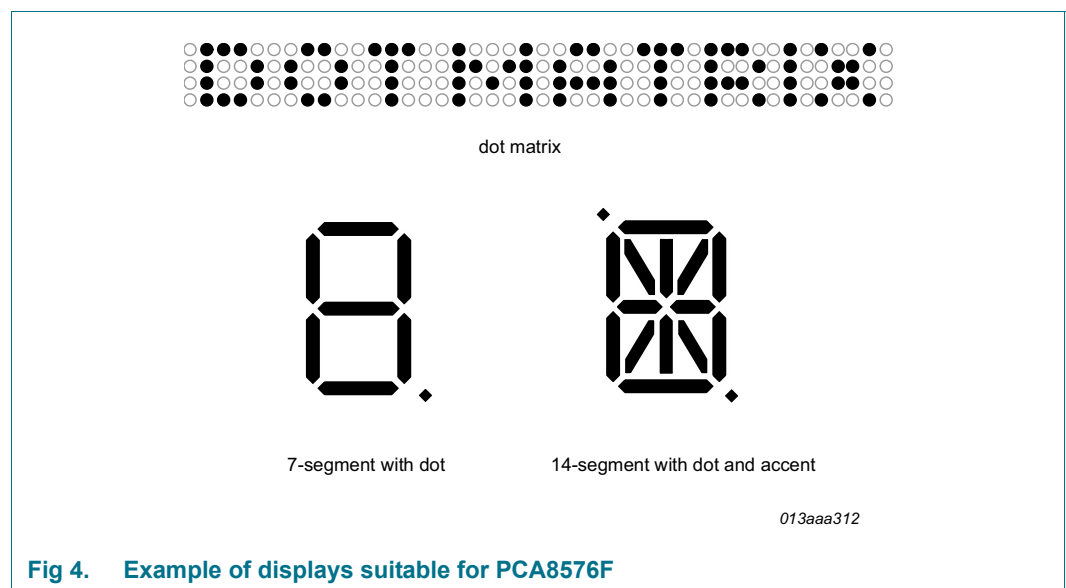

Fig 4. Example of displays suitable for PCA8576F

Table 12. Selection of possible display configurations

Number of Backplanes	Icons	Digits/Characters		Dot matrix/ Elements
		7-segment ^[1]	14-segment ^[2]	
4	160	20	10	160 (4 × 40)
3	120	15	7	120 (3 × 40)
2	80	10	5	80 (2 × 40)
1	40	5	2	40 (1 × 40)

[1] 7 segment display has 8 elements including the decimal point.

[2] 14 segment display has 16 elements including decimal point and accent dot.

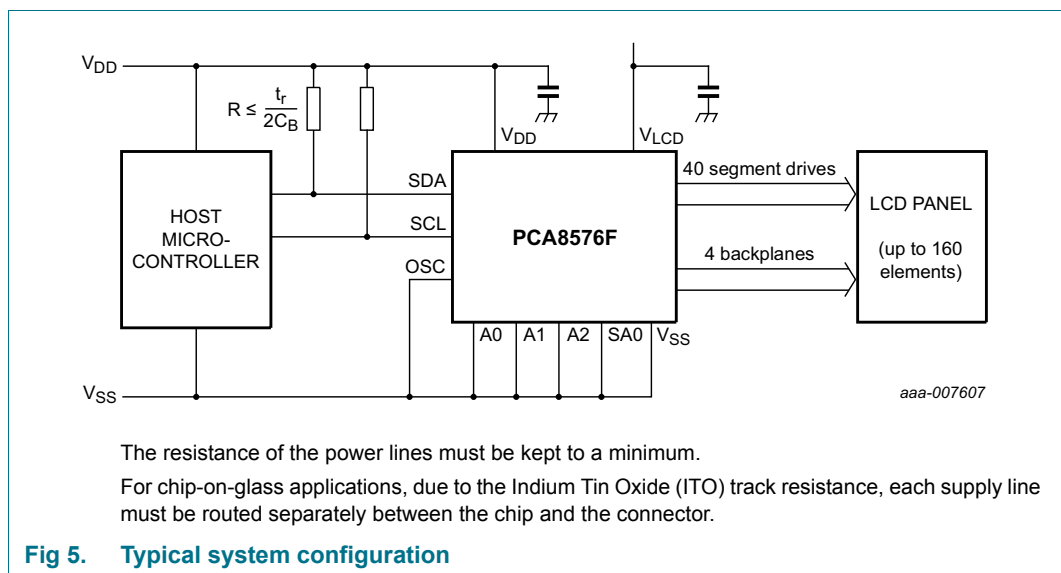

Fig 5. Typical system configuration

The host microcontroller maintains the 2-line I²C-bus communication channel with the PCA8576F. The internal oscillator is enabled by connecting pin OSC to pin V_{SS}. The appropriate biasing voltages for the multiplexed LCD waveforms are generated internally. The only other connections required to complete the system are to the power supplies (V_{DD}, V_{SS}, and V_{LCD}) and the LCD panel chosen for the application.

7.4 LCD voltage

7.4.1 LCD bias generator

Fractional LCD biasing voltages are obtained from an internal voltage divider of three impedances connected between pins V_{LCD} and V_{SS}. The center impedance is bypassed by switch if the 1/2 bias voltage level for the 1:2 multiplex drive mode configuration is selected. The LCD voltage can be temperature compensated externally using the supply to pin V_{LCD}.

7.4.2 LCD voltage selector

The LCD voltage selector coordinates the multiplexing of the LCD in accordance with the selected LCD drive configuration. The operation of the voltage selector is controlled by the mode-set command from the command decoder. The biasing configurations that apply to

the preferred modes of operation, together with the biasing characteristics as functions of V_{LCD} and the resulting discrimination ratios (D) are given in [Table 13](#).

Discrimination is a term which is defined as the ratio of the on and off RMS voltage across a segment. It can be thought of as a measurement of contrast.

Table 13. Biasing characteristics

LCD drive mode	Number of:		LCD bias configuration	$\frac{V_{off(RMS)}}{V_{LCD}}$	$\frac{V_{on(RMS)}}{V_{LCD}}$	$D = \frac{V_{on(RMS)}}{V_{off(RMS)}}$
	Backplanes	Levels				
static	1	2	static	0	1	∞
1:2 multiplex	2	3	$\frac{1}{2}$	0.354	0.791	2.236
1:2 multiplex	2	4	$\frac{1}{3}$	0.333	0.745	2.236
1:3 multiplex	3	4	$\frac{1}{3}$	0.333	0.638	1.915
1:4 multiplex	4	4	$\frac{1}{3}$	0.333	0.577	1.732

A practical value for V_{LCD} is determined by equating $V_{off(RMS)}$ with a defined LCD threshold voltage ($V_{th(off)}$), typically when the LCD exhibits approximately 10 % contrast. In the static drive mode a suitable choice is $V_{LCD} > 3V_{th(off)}$.

Multiplex drive modes of 1:3 and 1:4 with $\frac{1}{2}$ bias are possible but the discrimination and hence the contrast ratios are smaller.

Bias is calculated by $\frac{1}{1+a}$, where the values for a are

$$a = 1 \text{ for } \frac{1}{2} \text{ bias}$$

$$a = 2 \text{ for } \frac{1}{3} \text{ bias}$$

The RMS on-state voltage ($V_{on(RMS)}$) for the LCD is calculated with [Equation 1](#):

$$V_{on(RMS)} = V_{LCD} \sqrt{\frac{a^2 + 2a + n}{n \times (1 + a)^2}} \tag{1}$$

where the values for n are

$$n = 1 \text{ for static drive mode}$$

$$n = 2 \text{ for 1:2 multiplex drive mode}$$

$$n = 3 \text{ for 1:3 multiplex drive mode}$$

$$n = 4 \text{ for 1:4 multiplex drive mode}$$

The RMS off-state voltage ($V_{off(RMS)}$) for the LCD is calculated with [Equation 2](#):

$$V_{off(RMS)} = V_{LCD} \sqrt{\frac{a^2 - 2a + n}{n \times (1 + a)^2}} \tag{2}$$

Discrimination is the ratio of $V_{on(RMS)}$ to $V_{off(RMS)}$ and is determined from [Equation 3](#):

$$D = \frac{V_{on(RMS)}}{V_{off(RMS)}} = \sqrt{\frac{a^2 + 2a + n}{a^2 - 2a + n}} \tag{3}$$

Using [Equation 3](#), the discrimination for an LCD drive mode of 1:3 multiplex with $\frac{1}{2}$ bias is $\sqrt{3} = 1.732$ and the discrimination for an LCD drive mode of 1:4 multiplex with $\frac{1}{2}$ bias is $\frac{\sqrt{27}}{3} = 1.528$.

The advantage of these LCD drive modes is a reduction of the LCD full scale voltage V_{LCD} as follows:

- 1:3 multiplex ($\frac{1}{2}$ bias): $V_{LCD} = \sqrt{6} \times V_{off(RMS)} = 2.449V_{off(RMS)}$
- 1:4 multiplex ($\frac{1}{2}$ bias): $V_{LCD} = \left[\frac{(4 \times \sqrt{3})}{3} \right] = 2.309V_{off(RMS)}$

These compare with $V_{LCD} = 3V_{off(RMS)}$ when $\frac{1}{3}$ bias is used.

V_{LCD} is sometimes referred as the LCD operating voltage.

7.4.2.1 Electro-optical performance

Suitable values for $V_{on(RMS)}$ and $V_{off(RMS)}$ are dependent on the LCD liquid used. The RMS voltage, at which a pixel will be switched on or off, determine the transmissibility of the pixel.

For any given liquid, there are two threshold values defined. One point is at 10 % relative transmission (at $V_{th(off)}$) and the other at 90 % relative transmission (at $V_{th(on)}$), see [Figure 6](#). For a good contrast performance, the following rules should be followed:

$$V_{on(RMS)} \geq V_{th(on)} \tag{4}$$

$$V_{off(RMS)} \leq V_{th(off)} \tag{5}$$

$V_{on(RMS)}$ and $V_{off(RMS)}$ are properties of the display driver and are affected by the selection of a, n (see [Equation 1](#) to [Equation 3](#)) and the V_{LCD} voltage.

$V_{th(off)}$ and $V_{th(on)}$ are properties of the LCD liquid and can be provided by the module manufacturer. $V_{th(off)}$ is sometimes named V_{th} . $V_{th(on)}$ is sometimes named saturation voltage V_{sat} .

It is important to match the module properties to those of the driver in order to achieve optimum performance.

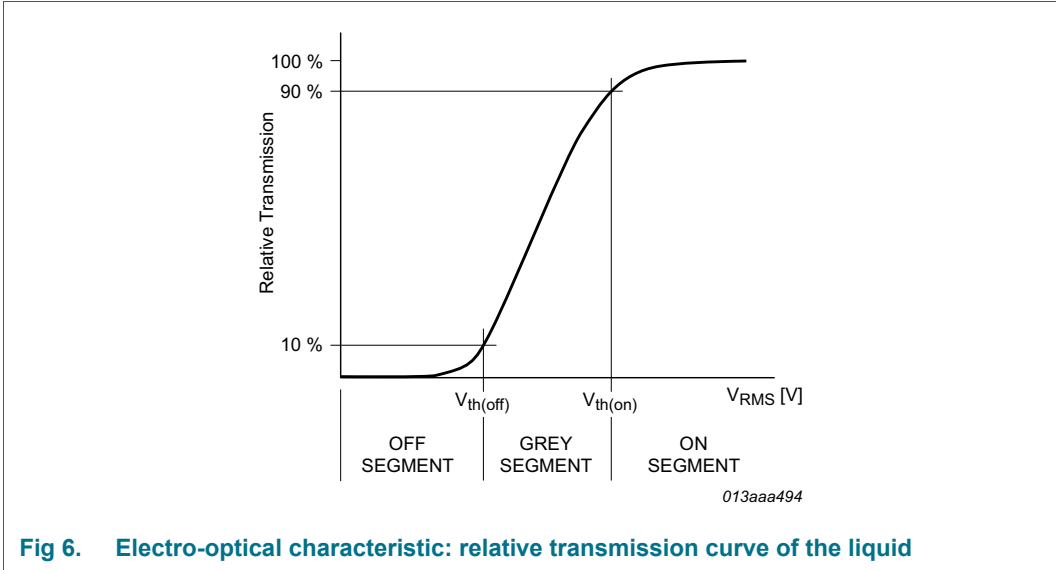
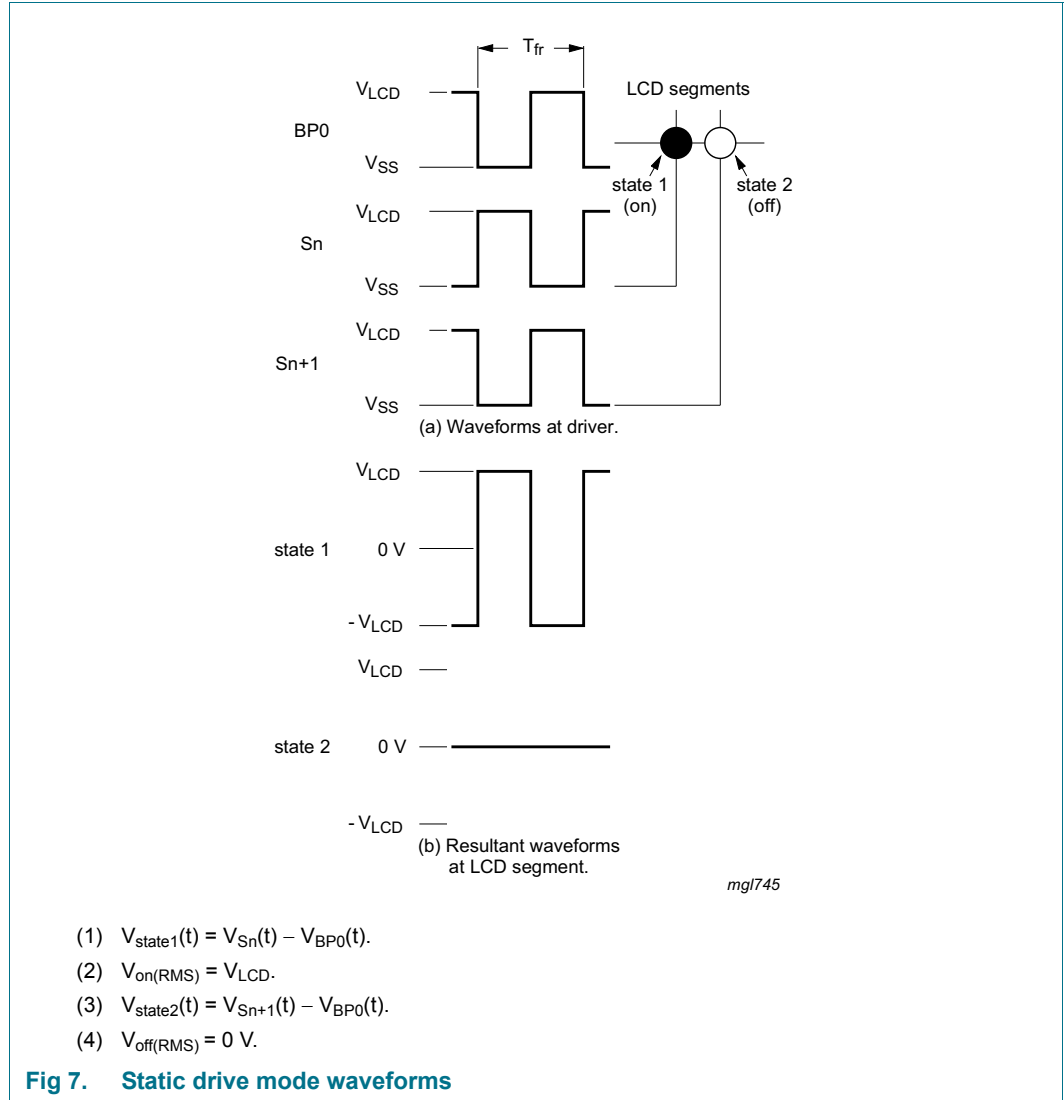

Fig 6. Electro-optical characteristic: relative transmission curve of the liquid

7.4.3 LCD drive mode waveforms

7.4.3.1 Static drive mode

The static LCD drive mode is used when a single backplane is provided in the LCD. The backplane (BP_n) and segment drive (S_n) waveforms for this mode are shown in [Figure 7](#).



7.4.3.2 1:2 Multiplex drive mode

The 1:2 multiplex drive mode is used when two backplanes are provided in the LCD. This mode allows fractional LCD bias voltages of $\frac{1}{2}$ bias or $\frac{1}{3}$ bias as shown in [Figure 8](#) and [Figure 9](#).

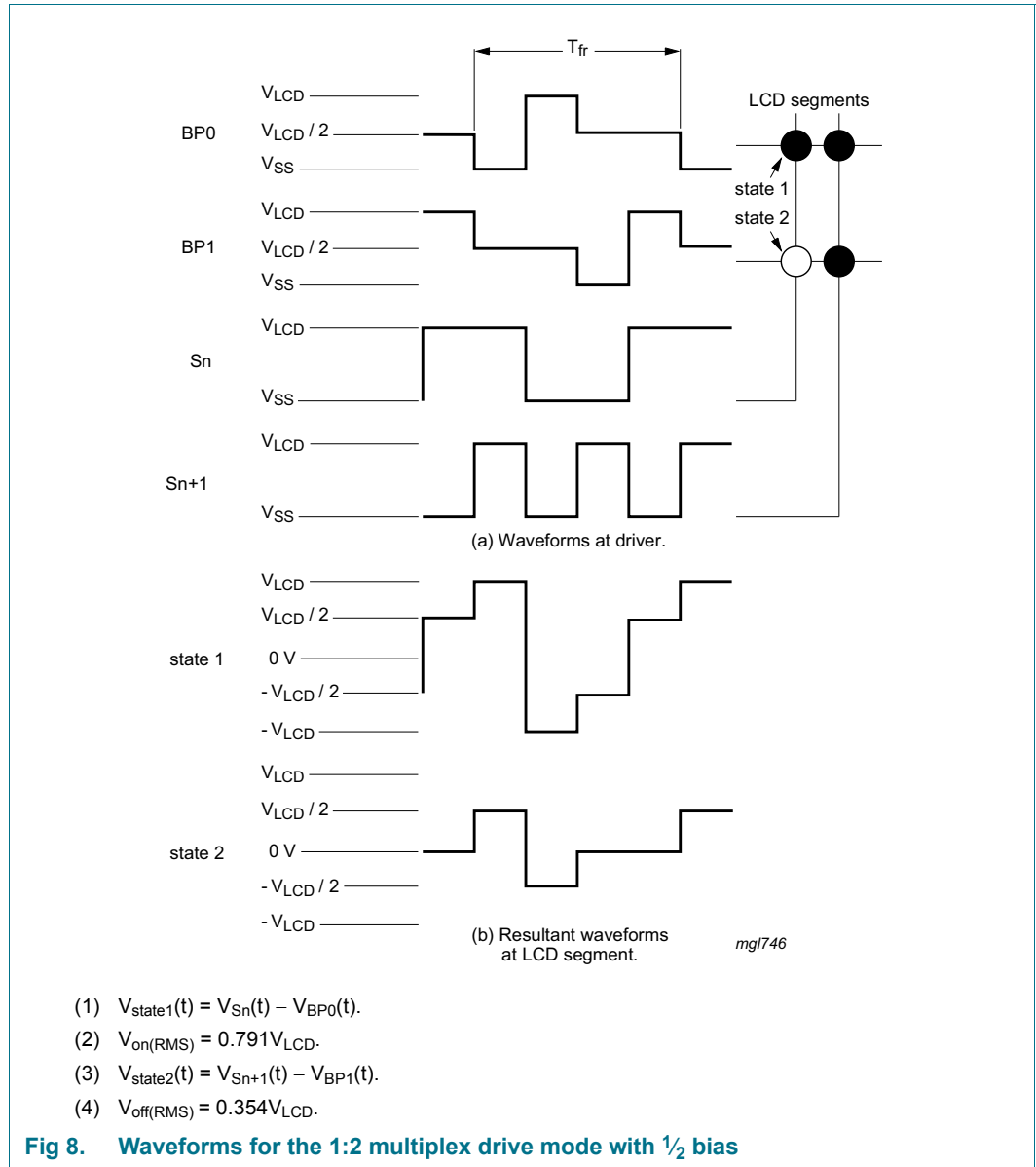
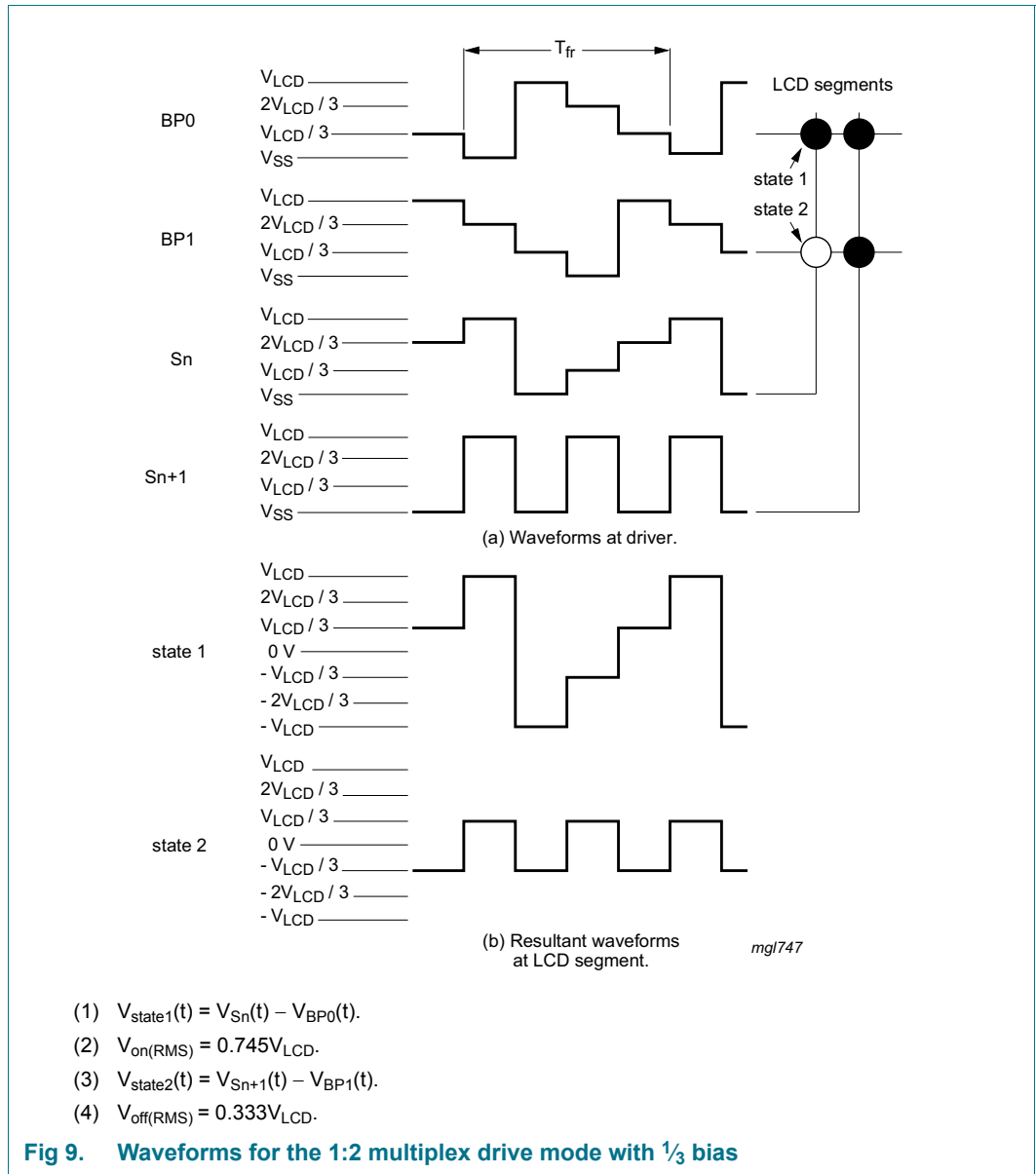
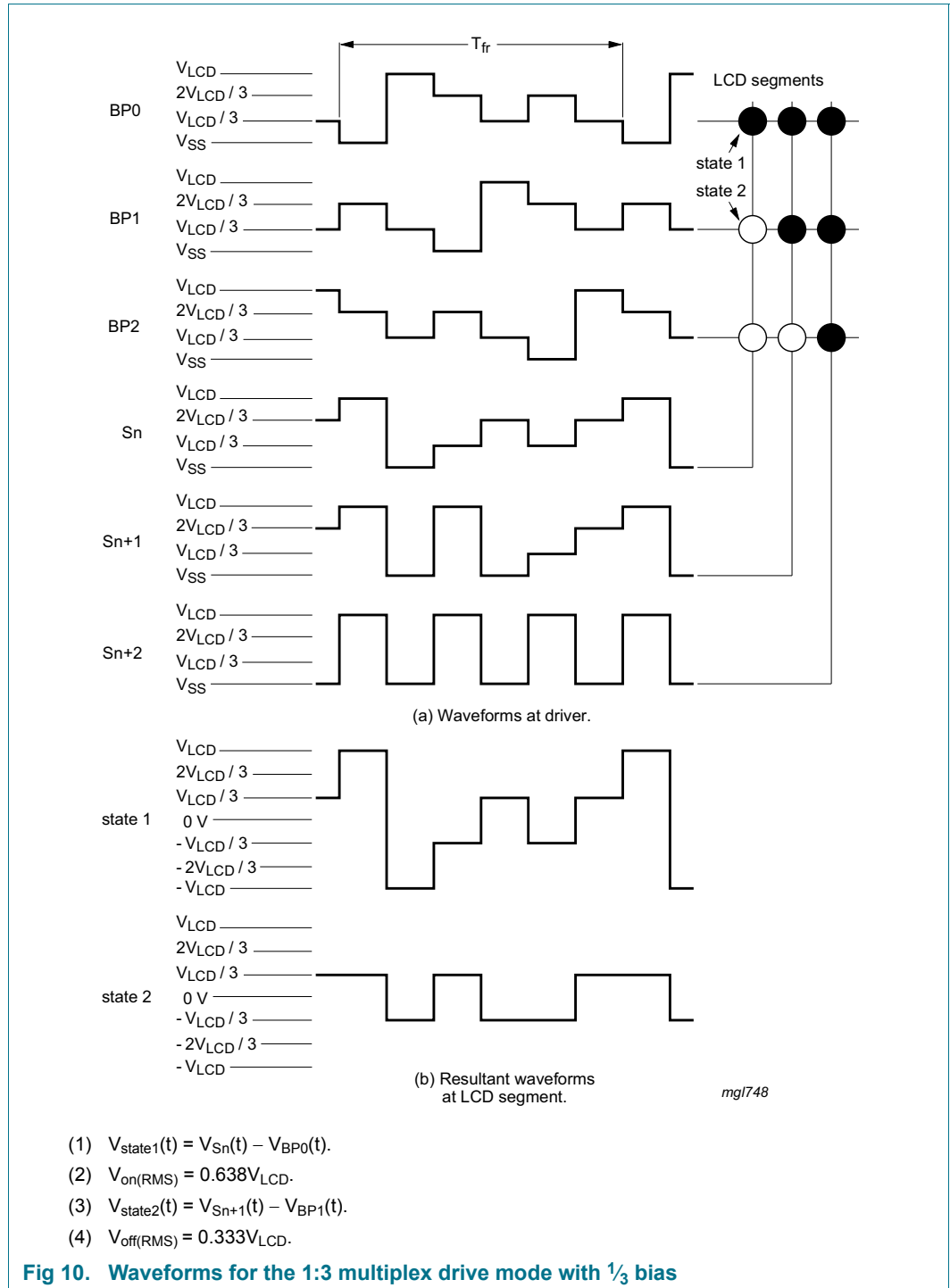

Fig 8. Waveforms for the 1:2 multiplex drive mode with $\frac{1}{2}$ bias



7.4.3.3 1:3 Multiplex drive mode

When three backplanes are provided in the LCD, the 1:3 multiplex drive mode applies (see Figure 10).



7.4.3.4 1:4 Multiplex drive mode

When four backplanes are provided in the LCD, the 1:4 multiplex drive mode applies (see Figure 11).

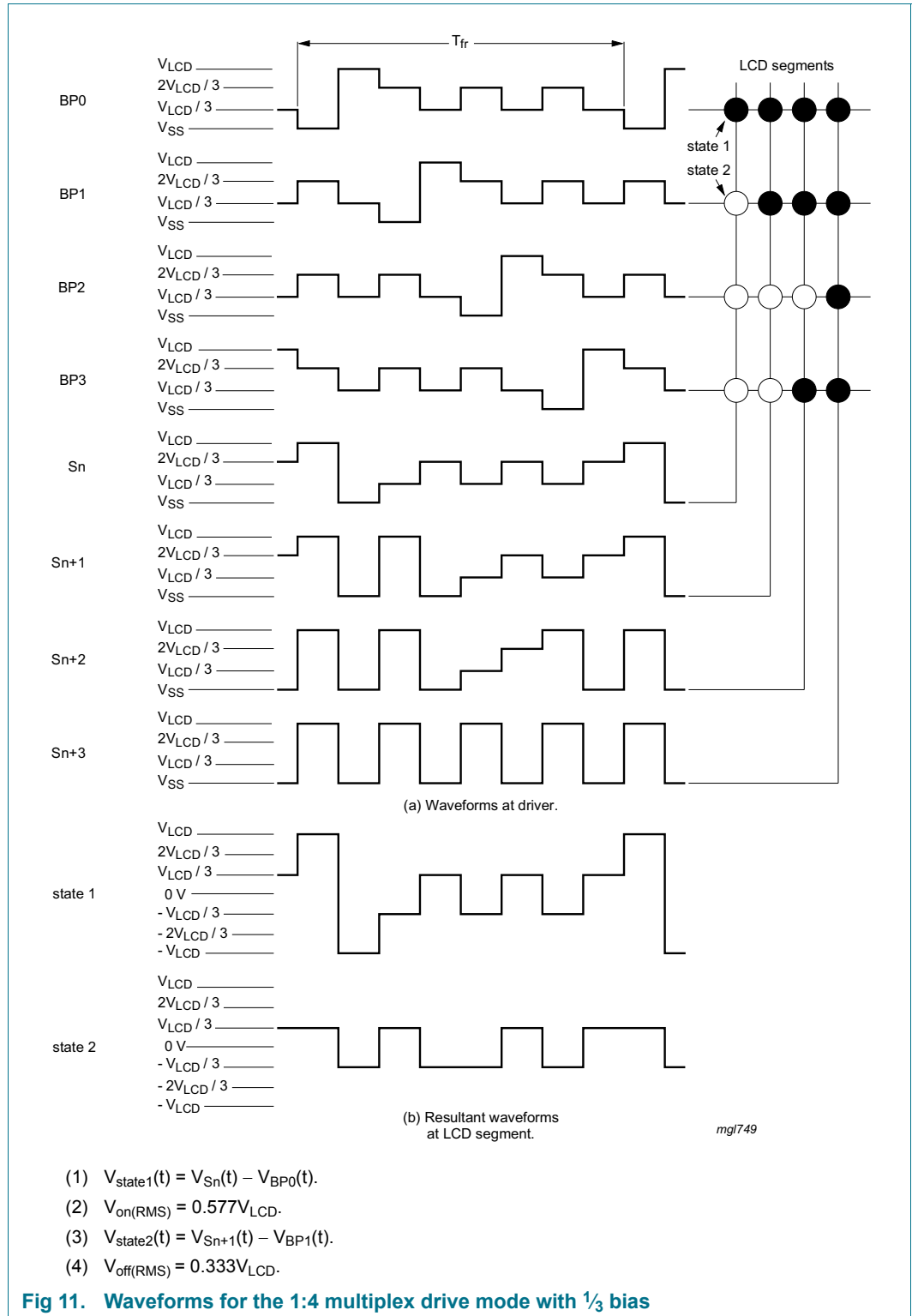

Fig 11. Waveforms for the 1:4 multiplex drive mode with 1/3 bias

7.5 Oscillator

7.5.1 Internal clock

The internal logic of the PCA8576F and its LCD drive signals are timed either by its internal oscillator or by an external clock. The internal oscillator is enabled by connecting pin OSC to pin V_{SS}. If the internal oscillator is used, the output from pin CLK can be used as the clock signal for several PCA8576Fs in the system that are connected in cascade.

7.5.2 External clock

Pin CLK is enabled as an external clock input by connecting pin OSC to V_{DD}. The LCD frame signal frequency is determined by the clock frequency (f_{clk}).

Remark: A clock signal must always be supplied to the device; removing the clock may freeze the LCD in a DC state, which is not suitable for the liquid crystal.

7.5.3 Timing and frame frequency

The PCA8576F timing controls the internal data flow of the device. This includes the transfer of display data from the display RAM to the display segment outputs. In cascaded applications, the correct timing relationship between each PCA8576F in the system is maintained by the synchronization signal at pin SYNC. The timing also generates the LCD frame signal whose frequency is derived from the clock frequency. The frame signal frequency is a fixed division of the clock frequency from either the internal or an external

$$\text{clock: } f_{fr} = \frac{f_{clk}}{24}.$$

7.6 Segment outputs

The LCD drive section includes 40 segment outputs S0 to S39 which should be connected directly to the LCD. The segment output signals are generated in accordance with the multiplexed backplane signals and with data residing in the display latch. When less than 40 segment outputs are required, the unused segment outputs should be left open-circuit.

7.7 Backplane outputs

The LCD drive section includes four backplane outputs BP0 to BP3 which must be connected directly to the LCD. The backplane output signals are generated in accordance with the selected LCD drive mode. If less than four backplane outputs are required, the unused outputs can be left open-circuit.

[Table 14](#) describes which outputs are active for each of the multiplex drive modes and what signal is generated.

Table 14. Mapping of output pins and corresponding output signals with respect to the multiplex driving mode

Multiplex drive mode	Output pin			
	BP0	BP1	BP2	BP3
	Signal			
1:4	BP0	BP1	BP2	BP3
1:3	BP0	BP1	BP2	BP1 ^[1]
1:2	BP0	BP1	BP0 ^[1]	BP1 ^[1]
static	BP0	BP0 ^[1]	BP0 ^[1]	BP0 ^[1]

[1] These pins may optionally be connected to the display to improve drive strength. Connect only with the corresponding output pin carrying the same signal. If not required, they can be left open-circuit.

7.8 Display register

The display latch holds the display data while the corresponding multiplex signals are generated.

7.9 Display RAM

The display RAM is a static 40 × 4-bit RAM which stores LCD data.

There is a one-to-one correspondence between

- the bits in the RAM bitmap and the LCD elements
- the RAM columns and the segment outputs
- the RAM rows and the backplane outputs.

A logic 1 in the RAM bitmap indicates the on-state of the corresponding LCD element; similarly, a logic 0 indicates the off-state.

The display RAM bit map, [Figure 12](#), shows the rows 0 to 3 which correspond with the backplane outputs BP0 to BP3, and the columns 0 to 39 which correspond with the segment outputs S0 to S39. In multiplexed LCD applications the segment data of the first, second, third and fourth row of the display RAM are time-multiplexed with BP0, BP1, BP2, and BP3 respectively.

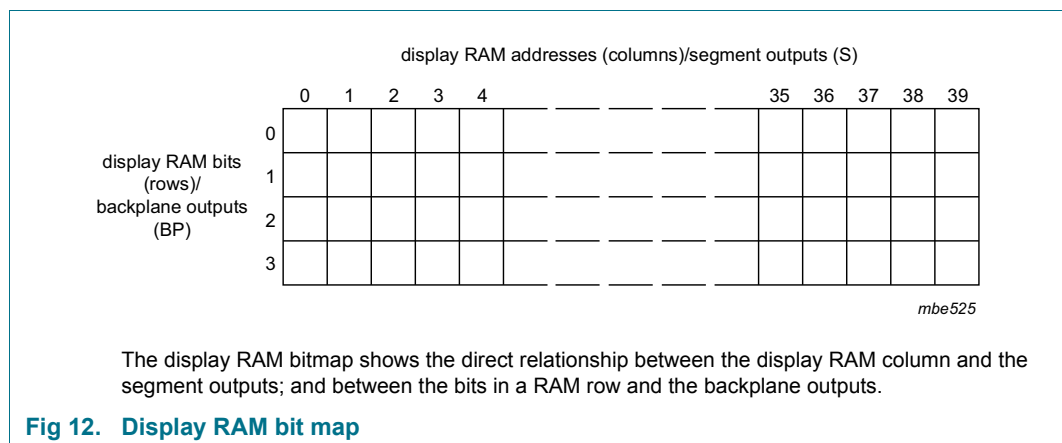

drive mode	LCD segments	LCD backplanes	display RAM filling order	transmitted display byte																																																									
static			<p>columns display RAM address/segment outputs (s) byte1</p> <table border="1"> <tr> <td></td> <td>n</td> <td>n + 1</td> <td>n + 2</td> <td>n + 3</td> <td>n + 4</td> <td>n + 5</td> <td>n + 6</td> <td>n + 7</td> </tr> <tr> <td>rows display RAM</td> <td>0</td> <td>c</td> <td>b</td> <td>a</td> <td>f</td> <td>g</td> <td>e</td> <td>d</td> <td>DP</td> </tr> <tr> <td>rows/backplane</td> <td>1</td> <td>x</td> <td>x</td> <td>x</td> <td>x</td> <td>x</td> <td>x</td> <td>x</td> <td>x</td> </tr> <tr> <td>outputs (BP)</td> <td>2</td> <td>x</td> <td>x</td> <td>x</td> <td>x</td> <td>x</td> <td>x</td> <td>x</td> <td>x</td> </tr> <tr> <td></td> <td>3</td> <td>x</td> <td>x</td> <td>x</td> <td>x</td> <td>x</td> <td>x</td> <td>x</td> <td>x</td> </tr> </table>		n	n + 1	n + 2	n + 3	n + 4	n + 5	n + 6	n + 7	rows display RAM	0	c	b	a	f	g	e	d	DP	rows/backplane	1	x	x	x	x	x	x	x	x	outputs (BP)	2	x	x	x	x	x	x	x	x		3	x	x	x	x	x	x	x	x	<p>MSB</p> <table border="1"> <tr> <td>c</td> <td>b</td> <td>a</td> <td>f</td> <td>g</td> <td>e</td> <td>d</td> <td>DP</td> </tr> </table> <p>LSB</p>	c	b	a	f	g	e	d	DP
	n	n + 1	n + 2	n + 3	n + 4	n + 5	n + 6	n + 7																																																					
rows display RAM	0	c	b	a	f	g	e	d	DP																																																				
rows/backplane	1	x	x	x	x	x	x	x	x																																																				
outputs (BP)	2	x	x	x	x	x	x	x	x																																																				
	3	x	x	x	x	x	x	x	x																																																				
c	b	a	f	g	e	d	DP																																																						
1:2 multiplex			<p>columns display RAM address/segment outputs (s) byte1</p> <table border="1"> <tr> <td></td> <td>n</td> <td>n + 1</td> <td>n + 2</td> <td>n + 3</td> </tr> <tr> <td>rows display RAM</td> <td>0</td> <td>a</td> <td>f</td> <td>e</td> <td>d</td> </tr> <tr> <td>rows/backplane</td> <td>1</td> <td>b</td> <td>g</td> <td>c</td> <td>DP</td> </tr> <tr> <td>outputs (BP)</td> <td>2</td> <td>x</td> <td>x</td> <td>x</td> <td>x</td> </tr> <tr> <td></td> <td>3</td> <td>x</td> <td>x</td> <td>x</td> <td>x</td> </tr> </table>		n	n + 1	n + 2	n + 3	rows display RAM	0	a	f	e	d	rows/backplane	1	b	g	c	DP	outputs (BP)	2	x	x	x	x		3	x	x	x	x	<p>MSB</p> <table border="1"> <tr> <td>a</td> <td>b</td> <td>f</td> <td>g</td> <td>e</td> <td>c</td> <td>d</td> <td>DP</td> </tr> </table> <p>LSB</p>	a	b	f	g	e	c	d	DP																				
	n	n + 1	n + 2	n + 3																																																									
rows display RAM	0	a	f	e	d																																																								
rows/backplane	1	b	g	c	DP																																																								
outputs (BP)	2	x	x	x	x																																																								
	3	x	x	x	x																																																								
a	b	f	g	e	c	d	DP																																																						
1:3 multiplex			<p>columns display RAM address/segment outputs (s) byte1</p> <table border="1"> <tr> <td></td> <td>n</td> <td>n + 1</td> <td>n + 2</td> </tr> <tr> <td>rows display RAM</td> <td>0</td> <td>b</td> <td>a</td> <td>f</td> </tr> <tr> <td>rows/backplane</td> <td>1</td> <td>DP</td> <td>d</td> <td>e</td> </tr> <tr> <td>outputs (BP)</td> <td>2</td> <td>c</td> <td>g</td> <td>x</td> </tr> <tr> <td></td> <td>3</td> <td>x</td> <td>x</td> <td>x</td> </tr> </table>		n	n + 1	n + 2	rows display RAM	0	b	a	f	rows/backplane	1	DP	d	e	outputs (BP)	2	c	g	x		3	x	x	x	<p>MSB</p> <table border="1"> <tr> <td>b</td> <td>DP</td> <td>c</td> <td>a</td> <td>d</td> <td>g</td> <td>f</td> <td>e</td> </tr> </table> <p>LSB</p>	b	DP	c	a	d	g	f	e																									
	n	n + 1	n + 2																																																										
rows display RAM	0	b	a	f																																																									
rows/backplane	1	DP	d	e																																																									
outputs (BP)	2	c	g	x																																																									
	3	x	x	x																																																									
b	DP	c	a	d	g	f	e																																																						
1:4 multiplex			<p>columns display RAM address/segment outputs (s) byte1</p> <table border="1"> <tr> <td></td> <td>n</td> <td>n + 1</td> </tr> <tr> <td>rows display RAM</td> <td>0</td> <td>a</td> <td>f</td> </tr> <tr> <td>rows/backplane</td> <td>1</td> <td>c</td> <td>e</td> </tr> <tr> <td>outputs (BP)</td> <td>2</td> <td>b</td> <td>g</td> </tr> <tr> <td></td> <td>3</td> <td>DP</td> <td>d</td> </tr> </table>		n	n + 1	rows display RAM	0	a	f	rows/backplane	1	c	e	outputs (BP)	2	b	g		3	DP	d	<p>MSB</p> <table border="1"> <tr> <td>a</td> <td>c</td> <td>b</td> <td>DP</td> <td>f</td> <td>e</td> <td>g</td> <td>d</td> </tr> </table> <p>LSB</p>	a	c	b	DP	f	e	g	d																														
	n	n + 1																																																											
rows display RAM	0	a	f																																																										
rows/backplane	1	c	e																																																										
outputs (BP)	2	b	g																																																										
	3	DP	d																																																										
a	c	b	DP	f	e	g	d																																																						

001aaJ646

x = data bit unchanged.

Fig 13. Relationship between LCD layout, drive mode, display RAM filling order and display data transmitted over the I²C-bus

When display data is transmitted to the PCA8576F, the received display bytes are stored in the display RAM in accordance with the selected LCD drive mode. The data is stored as it arrives and depending on the current multiplex drive mode the bits are stored singularly, in pairs, triples, or quadruples. To illustrate the filling order, an example of a 7-segment display showing all drive modes is given in [Figure 13](#); the RAM filling organization depicted applies equally to other LCD types, see [Section 7.9.1](#) to [Section 7.9.4](#).

7.9.1 RAM filling in static drive mode

In the static drive mode the eight transmitted data bits are placed in eight successive display RAM columns in row 0 (see [Figure 14](#)).

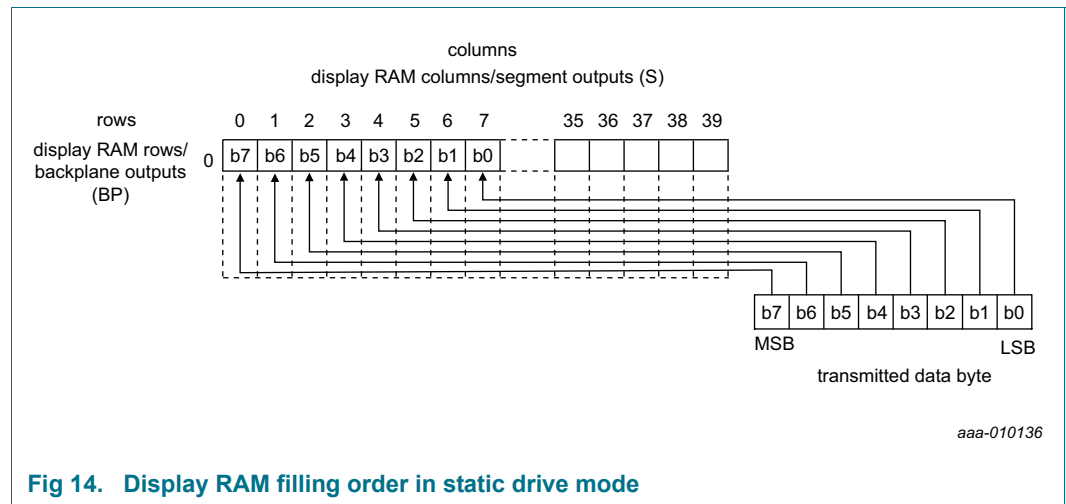

Fig 14. Display RAM filling order in static drive mode

7.9.2 RAM filling in 1:2 multiplex drive mode

In the 1:2 multiplex drive mode the eight transmitted data bits are placed in four successive display RAM columns of two rows (see [Figure 15](#)).

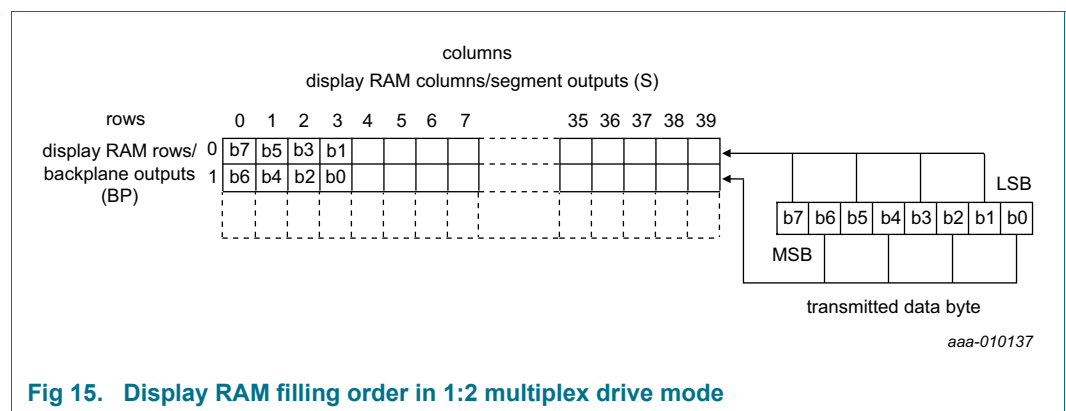

Fig 15. Display RAM filling order in 1:2 multiplex drive mode

7.9.3 RAM filling in 1:3 multiplex drive mode

In 1:3 multiplex drive mode, the RAM is written as shown in [Table 15](#) (see [Figure 13](#) as well).

Table 15. Standard RAM filling in 1:3 multiplex drive mode

Assumption: BP2/S2, BP2/S5, BP2/S8 etc. **are not connected** to any elements on the display.

Display RAM bits (rows)/ backplane outputs (BPn)	Display RAM addresses (columns)/segment outputs (Sn)										
	0	1	2	3	4	5	6	7	8	9	:
0	a7	a4	a1	b7	b4	b1	c7	c4	c1	d7	:
1	a6	a3	a0	b6	b3	b0	c6	c3	c0	d6	:
2	a5	a2	-	b5	b2	-	c5	c2	-	d5	:
3	-	-	-	-	-	-	-	-	-	-	:

If the bit at position BP2/S2 would be written by a second byte transmitted, then the mapping of the segment bits would change as illustrated in [Table 16](#).

Table 16. Entire RAM filling by rewriting in 1:3 multiplex drive mode

Assumption: BP2/S2, BP2/S5, BP2/S8 etc. **are connected** to elements on the display.

Display RAM bits (rows)/ backplane outputs (BPn)	Display RAM addresses (columns)/segment outputs (Sn)										
	0	1	2	3	4	5	6	7	8	9	:
0	a7	a4	a1/b7	b4	b1/c7	c4	c1/d7	d4	d1/e7	e4	:
1	a6	a3	a0/b6	b3	b0/c6	c3	c0/d6	d3	d0/e6	e3	:
2	a5	a2	b5	b2	c5	c2	d5	d2	e5	e2	:
3	-	-	-	-	-	-	-	-	-	-	:

In the case described in [Table 16](#) the RAM has to be written entirely and BP2/S2, BP2/S5, BP2/S8 etc. have to be connected to elements on the display. This can be achieved by a combination of writing and rewriting the RAM like follows:

- In the first write to the RAM, bits a7 to a0 are written.
- In the second write, bits b7 to b0 are written, overwriting bits a1 and a0 with bits b7 and b6.
- In the third write, bits c7 to c0 are written, overwriting bits b1 and b0 with bits c7 and c6.

Depending on the method of writing to the RAM (standard or entire filling by rewriting), some elements remain unused or can be used, but it has to be considered in the module layout process as well as in the driver software design.

7.9.4 RAM filling in 1:4 multiplex drive mode

In the 1:4 multiplex drive mode the eight transmitted data bits are placed in two successive display RAM columns of four rows (see [Figure 16](#)).

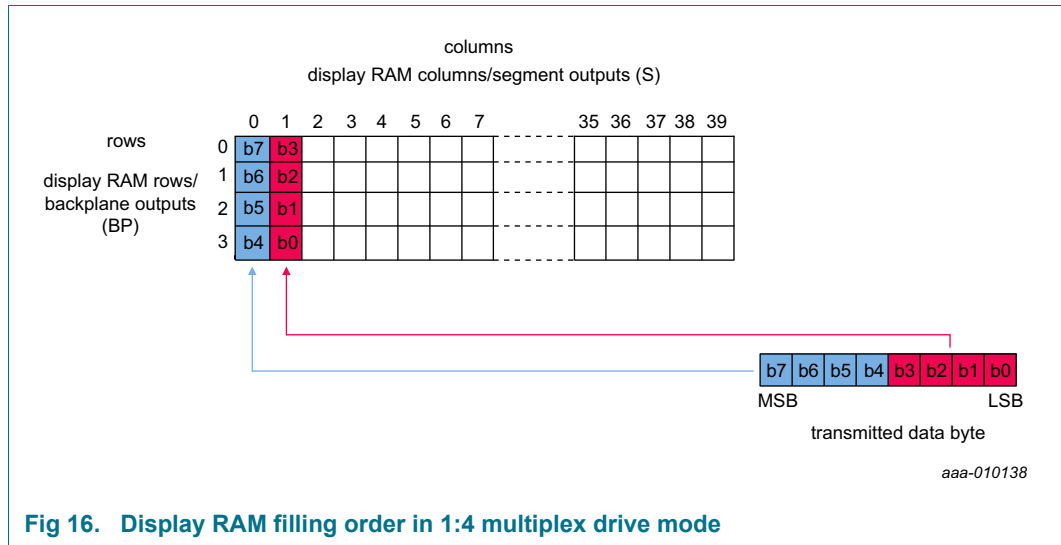

7.9.5 Data pointer

The addressing mechanism for the display RAM is realized using the data pointer. This allows the loading of an individual display data byte, or a series of display data bytes, into any location of the display RAM. The sequence commences with the initialization of the data pointer by the load-data-pointer command (see Table 8). Following this command, an arriving data byte is stored at the display RAM address indicated by the data pointer. The filling order is shown in Figure 13. After each byte is stored, the content of the data pointer is automatically incremented by a value dependent on the selected LCD drive mode:

- In static drive mode by eight.
- In 1:2 multiplex drive mode by four.
- In 1:3 multiplex drive mode by three.
- In 1:4 multiplex drive mode by two.

If an I²C-bus data access terminates early then the state of the data pointer is unknown. Consequently, the data pointer must be rewritten prior to further RAM accesses.

7.9.6 Subaddress counter

The storage of display data is determined by the contents of the subaddress counter. Storage is allowed only when the content of the subaddress counter match with the hardware subaddress applied to A0, A1, and A2. The subaddress counter value is defined by the device-select command (see Table 9). If the content of the subaddress counter and the hardware subaddress do not match then data storage is inhibited but the data pointer is incremented as if data storage had taken place. The subaddress counter is also incremented when the data pointer overflows.

The storage arrangements described lead to extremely efficient data loading in cascaded applications. When a series of display bytes are sent to the display RAM, automatic wrap-over to the next PCA8576F occurs when the last RAM address is exceeded. Subaddressing across device boundaries is successful even if the change to the next device in the cascade occurs within a transmitted character.

The hardware subaddress must not be changed while the device is being accessed on the I²C-bus interface.

7.9.7 Writing over the RAM address boundary

In all multiplex drive modes, depending on the setting of the data pointer, it is possible to fill the RAM over the RAM address boundary. If the PCA8576F is part of a cascade the additional bits fall into the next device that also generates the acknowledge signal. If the PCA8576F is a single device or the last device in a cascade the additional bits will be discarded and no acknowledge signal will be generated.

7.9.8 Bank selection

7.9.8.1 RAM bank switching

The PCA8576F includes a RAM bank switching feature in the static and 1:2 multiplex drive modes. A bank can be thought of as one RAM row or a collection of RAM rows (see [Figure 17](#)). The RAM bank switching gives the provision for preparing display information in an alternative bank and to be able to switch to it once it is complete.

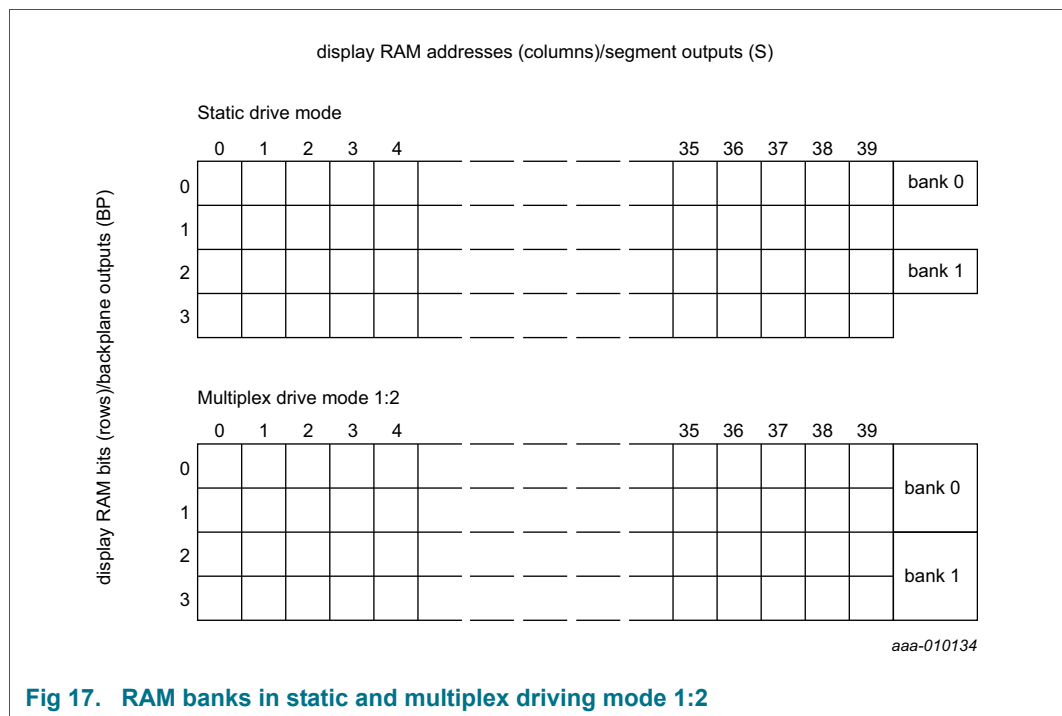

Fig 17. RAM banks in static and multiplex driving mode 1:2

There are two banks; bank 0 and bank 1. [Figure 17](#) shows the location of these banks relative to the RAM map. Input and output banks can be set independently from one another with the Bank-select command (see [Table 10 on page 8](#)). [Figure 18](#) shows the concept.

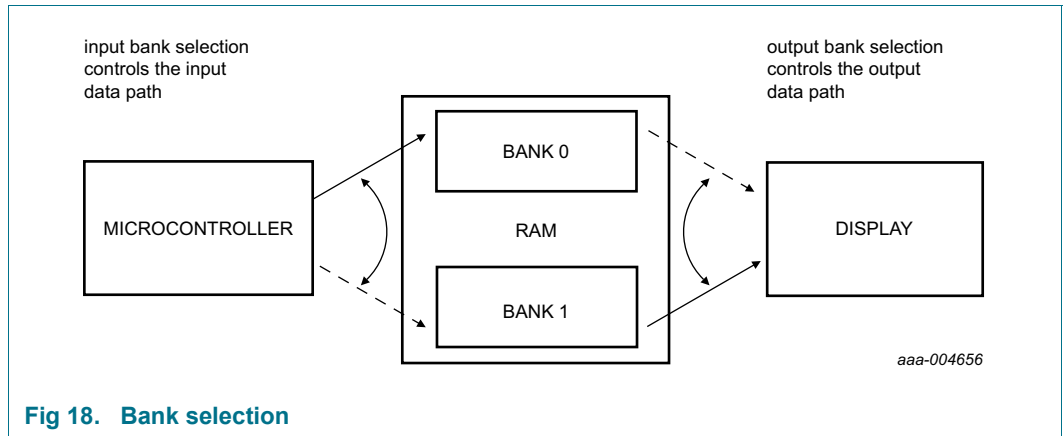

Fig 18. Bank selection

In the static drive mode, the bank-select command may request the contents of row 2 to be selected for display instead of the contents of row 0. In the 1:2 multiplex mode, the contents of rows 2 and 3 may be selected instead of rows 0 and 1. This gives the provision for preparing display information in an alternative bank and to be able to switch to it once it is assembled.

In [Figure 19](#) an example is shown for 1:2 multiplex drive mode where the displayed data is read from the first two rows of the memory (bank 0), while the transmitted data is stored in the second two rows of the memory (bank 1).

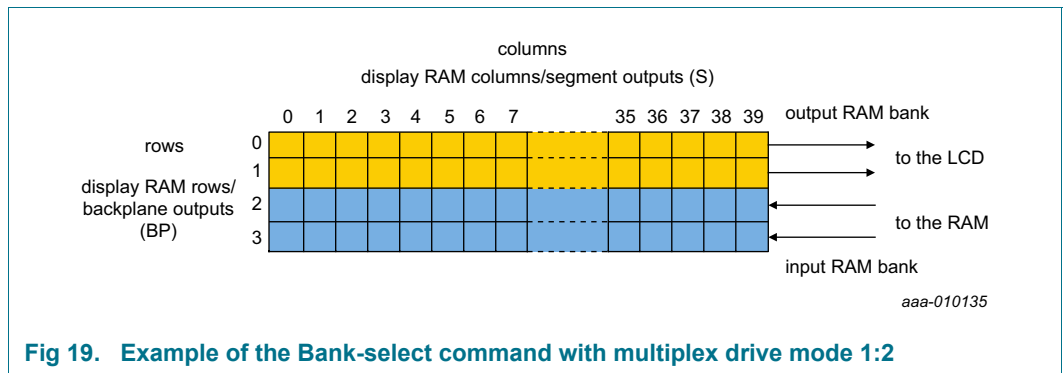

Fig 19. Example of the Bank-select command with multiplex drive mode 1:2

7.9.8.2 Output bank selector

The output bank selector (see [Table 10](#)) selects one of the four rows per display RAM address for transfer to the display register. The actual row selected depends on the selected LCD drive mode in operation and on the instant in the multiplex sequence.

- In 1:4 multiplex mode, all RAM addresses of row 0 are selected, these are followed by the contents of row 1, 2, and then 3
- In 1:3 multiplex mode, rows 0, 1, and 2 are selected sequentially
- In 1:2 multiplex mode, rows 0 and 1 are selected
- In static mode, row 0 is selected

7.9.8.3 Input bank selector

The input bank selector loads display data into the display RAM in accordance with the selected LCD drive configuration. Display data can be loaded in row 2 in static drive mode or in rows 2 and 3 in 1:2 multiplex drive mode by using the bank-select command (see

[Table 10](#)). The input bank selector functions independently to the output bank selector.

7.10 Blinking

The display blinking capabilities of the PCA8576F are very versatile. The whole display can blink at frequencies selected by the blink-select command (see [Table 11](#)). The blink frequencies are derived from the clock frequency. The ratio between the clock and blink frequencies depends on the blink mode selected (see [Table 11](#)).

An additional feature is for an arbitrary selection of LCD elements to blink. This applies to the static and 1:2 multiplex drive modes and can be implemented without any communication overheads. By means of the output bank selector, the displayed RAM banks are exchanged with alternate RAM banks at the blink frequency. This mode can also be specified by the blink-select command.

In the 1:3 and 1:4 multiplex modes, where no alternative RAM bank is available, groups of LCD elements can blink by selectively changing the display RAM data at fixed time intervals.

The entire display can blink at a frequency other than the nominal blink frequency. This can be effectively performed by resetting and setting the display enable bit E at the required rate using the mode-set command (see [Table 7](#)).

Table 17. Blinking frequencies

Blink mode	Normal operating mode ratio	Nominal blink frequency ^[1]	Unit
off	-	blinking off	Hz
1	$\frac{f_{clk}}{768}$	6.2	Hz
2	$\frac{f_{clk}}{1536}$	3.1	Hz
3	$\frac{f_{clk}}{3072}$	1.6	Hz

[1] Blink modes 1, 2 and 3 and the nominal blink frequencies correspond to an oscillator frequency (f_{clk}) of 4800 Hz (see [Section 13](#)).

7.11 Display controller

The display controller executes the commands identified by the command decoder. It contains the device's status registers and coordinates their effects. The display controller is also responsible for loading display data into the display RAM in the correct filling order.

8. Characteristics of the I²C-bus

The I²C-bus is for bidirectional, two-line communication between different ICs or modules. The two lines are a Serial DATA line (SDA) and a Serial CLOCK line (SCL). Both lines must be connected to a positive supply via a pull-up resistor when connected to the output stages of a device. Data transfer may be initiated only when the bus is not busy.

8.1 Bit transfer

One data bit is transferred during each clock pulse. The data on the SDA line must remain stable during the HIGH period of the clock pulse as changes in the data line at this time will be interpreted as a control signal (see [Figure 20](#)).

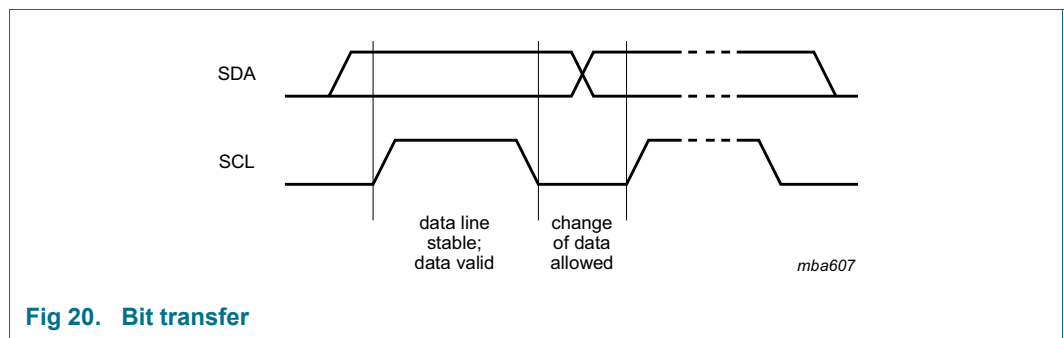

Fig 20. Bit transfer

8.1.1 START and STOP conditions

Both data and clock lines remain HIGH when the bus is not busy.

A HIGH-to-LOW transition of the data line while the clock is HIGH is defined as the START condition - S.

A LOW-to-HIGH transition of the data line while the clock is HIGH is defined as the STOP condition - P.

The START and STOP conditions are illustrated in [Figure 21](#).

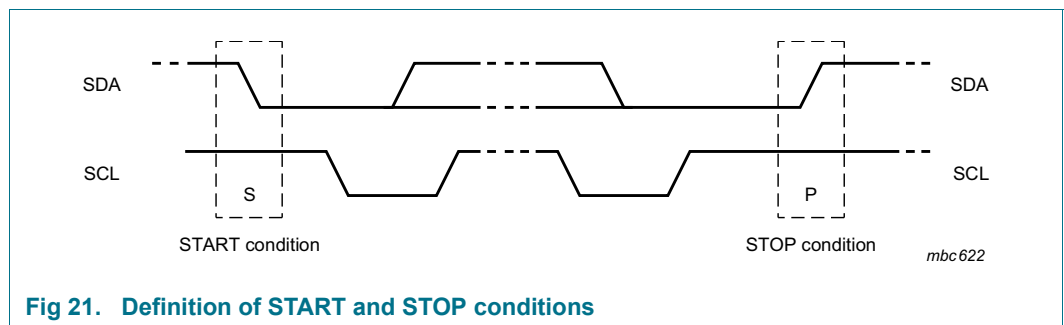

Fig 21. Definition of START and STOP conditions

8.2 System configuration

A device generating a message is a transmitter, a device receiving a message is the receiver. The device that controls the message is the master and the devices which are controlled by the master are the slaves. The system configuration is shown in [Figure 22](#).

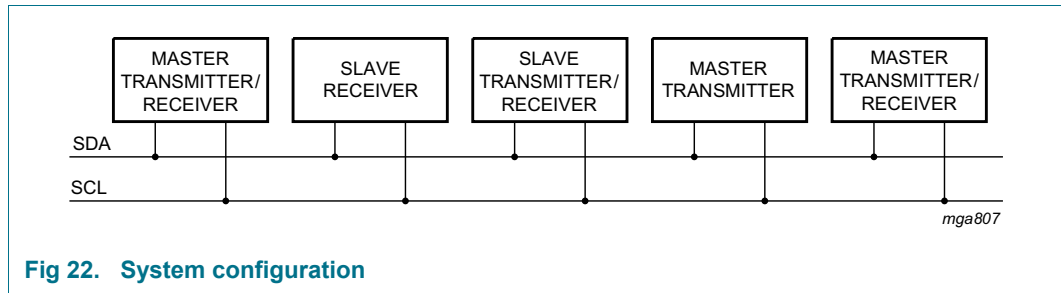

Fig 22. System configuration

8.3 Acknowledge

The number of data bytes transferred between the START and STOP conditions from transmitter to receiver is unlimited. Each byte of eight bits is followed by an acknowledge cycle.

- A slave receiver, which is addressed, must generate an acknowledge after the reception of each byte.
- A master receiver must generate an acknowledge after the reception of each byte that has been clocked out of the slave transmitter.
- The device that acknowledges must pull-down the SDA line during the acknowledge clock pulse, so that the SDA line is stable LOW during the HIGH period of the acknowledge related clock pulse (set-up and hold times must be taken into consideration).
- A master receiver must signal an end of data to the transmitter by not generating an acknowledge on the last byte that has been clocked out of the slave. In this event, the transmitter must leave the data line HIGH to enable the master to generate a STOP condition.

Acknowledgement on the I²C-bus is illustrated in [Figure 23](#).

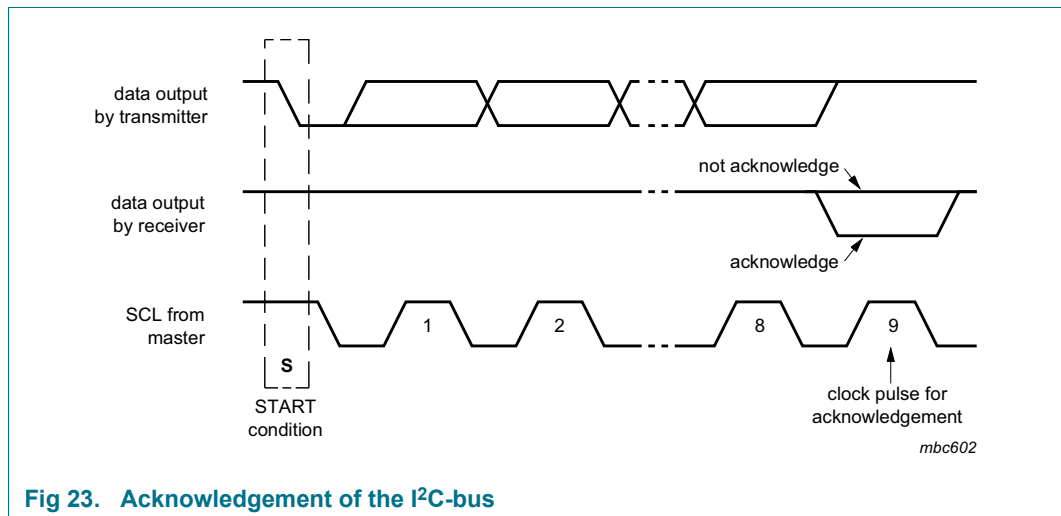

Fig 23. Acknowledgement of the I²C-bus

8.4 I²C-bus controller

The PCA8576F acts as an I²C-bus slave receiver. It does not initiate I²C-bus transfers or transmit data to an I²C-bus master receiver. The only data output from the PCA8576F are the acknowledge signals of the selected devices. Device selection depends on the I²C-bus slave address, on the transferred command data and on the hardware subaddress.

In single device applications, the hardware subaddress inputs A0, A1, and A2 are normally tied to V_{SS} which defines the hardware subaddress 0. In multiple device applications A0, A1, and A2 are tied to V_{SS} or V_{DD} using a binary coding scheme, so that no two devices with a common I²C-bus slave address have the same hardware subaddress.

8.5 Input filters

To enhance noise immunity in electrically adverse environments, RC low-pass filters are provided on the SDA and SCL lines.

8.6 I²C-bus protocol

Two I²C-bus slave addresses (0111 000 and 0111 001) are used to address the PCA8576F. The entire I²C-bus slave address byte is shown in [Table 18](#).

Table 18. I²C slave address byte

Bit	Slave address							0 LSB
	7 MSB	6	5	4	3	2	1	
	0	1	1	1	0	0	SA0	R/ \overline{W}

The PCA8576F is a write-only device and will not respond to a read access, therefore bit 0 should always be logic 0. Bit 1 of the slave address byte that a PCA8576F will respond to, is defined by the level tied to its SA0 input (V_{SS} for logic 0 and V_{DD} for logic 1).

Having two reserved slave addresses allows the following on the same I²C-bus:

- Up to 16 PCA8576F for very large LCD applications
- The use of two types of LCD multiplex drive

The I²C-bus protocol is shown in [Figure 24](#). The sequence is initiated with a START condition (S) from the I²C-bus master which is followed by one of two possible PCA8576F slave addresses available. All PCA8576Fs whose SA0 inputs correspond to bit 0 of the slave address respond by asserting an acknowledge in parallel. This I²C-bus transfer is ignored by all PCA8576Fs whose SA0 inputs are set to the alternative level.

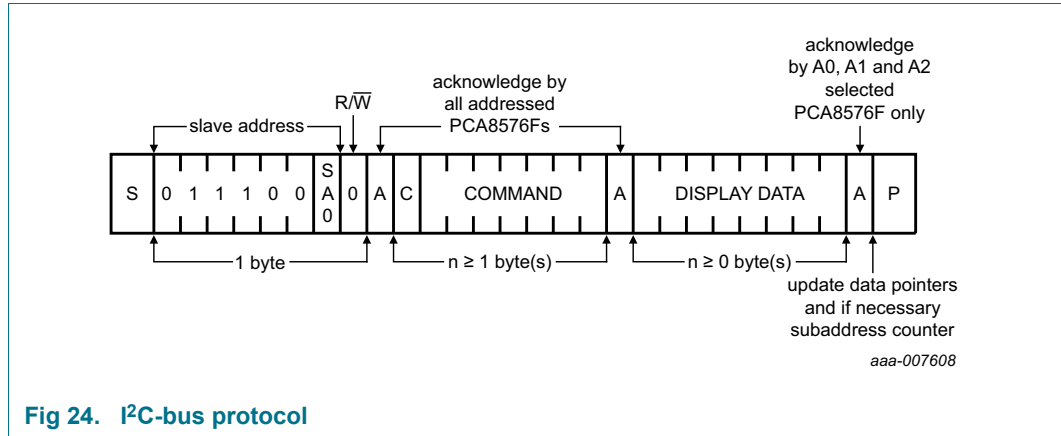

Fig 24. I²C-bus protocol

After an acknowledgement, one or more command bytes follow, that define the status of each addressed PCA8576F.

The last command byte sent is identified by resetting its most significant bit, continuation bit C, (see [Section 7.1](#)). The command bytes are also acknowledged by all addressed PCA8576F on the bus.

After the last command byte, one or more display data bytes may follow. Display data bytes are stored in the display RAM at the address specified by the data pointer and the subaddress counter. Both data pointer and subaddress counter are automatically updated and the data directed to the intended PCA8576F device.

An acknowledgement after each byte is asserted only by the PCA8576Fs that are addressed via address lines A0, A1, and A2. After the last display byte, the I²C-bus master asserts a STOP condition (P). Alternately a START may be asserted to restart an I²C-bus access.

9. Internal circuitry

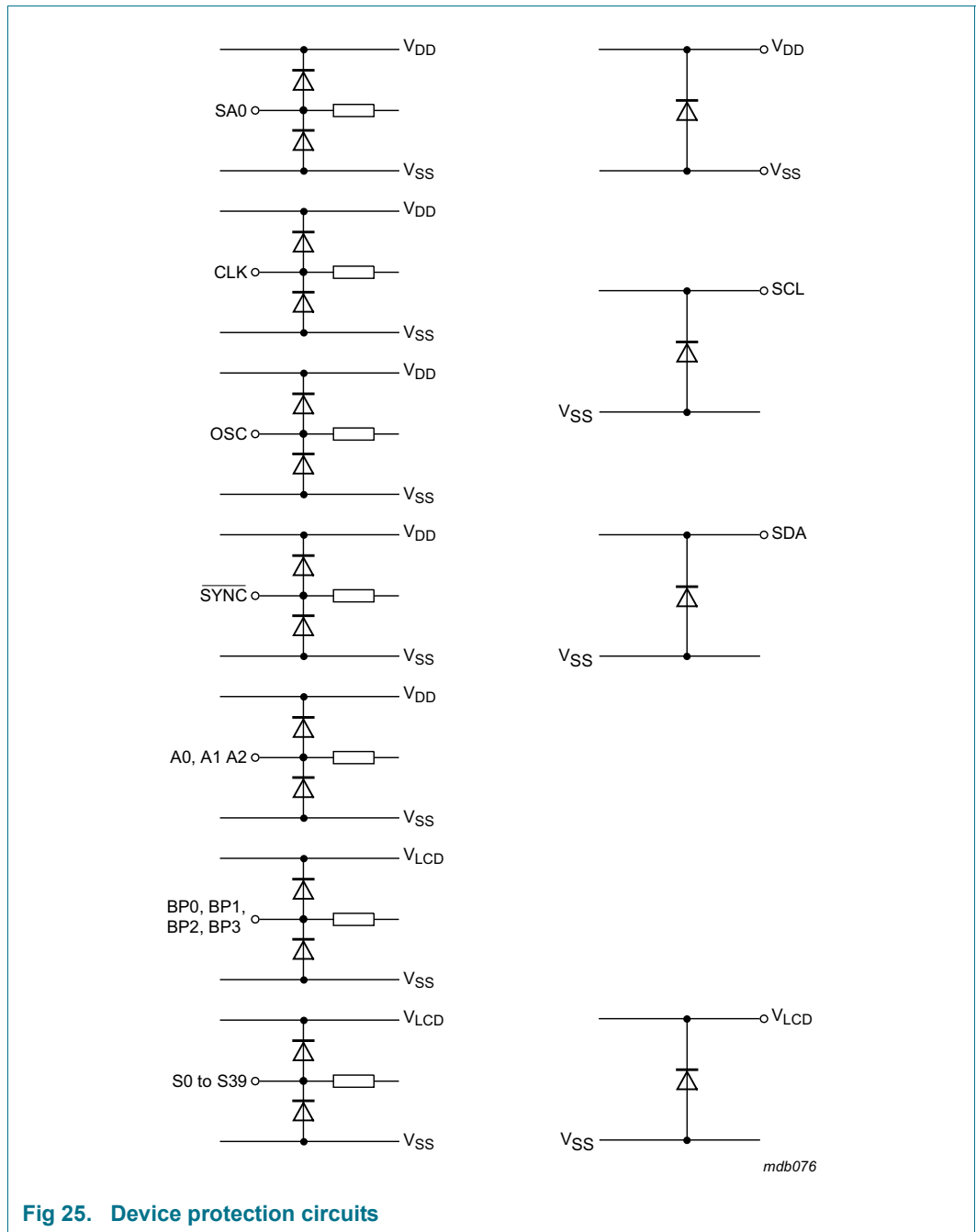

10. Safety notes

CAUTION



This device is sensitive to ElectroStatic Discharge (ESD). Observe precautions for handling electrostatic sensitive devices.

Such precautions are described in the *ANSI/ESD S20.20*, *IEC/ST 61340-5*, *JESD625-A* or equivalent standards.

CAUTION



Static voltages across the liquid crystal display can build up when the LCD supply voltage (V_{LCD}) is on while the IC supply voltage (V_{DD}) is off, or vice versa. This may cause unwanted display artifacts. To avoid such artifacts, V_{LCD} and V_{DD} must be applied or removed together.

CAUTION



Semiconductors are light sensitive. Exposure to light sources can cause the IC to malfunction. The IC must be protected against light. The protection must be applied to all sides of the IC.

11. Limiting values

Table 19. Limiting values

In accordance with the Absolute Maximum Rating System (IEC 60134).

Symbol	Parameter	Conditions	Min	Max	Unit
V_{DD}	supply voltage		-0.5	+6.5	V
V_{LCD}	LCD supply voltage		-0.5	+9.0	V
V_I	input voltage	on each of the pins CLK, SDA, SCL, SYNC, SA0, OSC, A0 to A2	-0.5	+6.5	V
V_O	output voltage	on each of the pins S0 to S39, BP0 to BP3	-0.5	+9.0	V
I_I	input current		-10	+10	mA
I_O	output current		-10	+10	mA
I_{DD}	supply current		-50	+50	mA
$I_{DD(LCD)}$	LCD supply current		-50	+50	mA
I_{SS}	ground supply current		-50	+50	mA
P_{tot}	total power dissipation		-	400	mW
P_o	output power		-	100	mW
V_{ESD}	electrostatic discharge voltage	HBM	[1] -	±5000	V
I_{lu}	latch-up current	$V_{LU(VLCD)} = 11.5\text{ V}$	[2] -	200	mA
T_{stg}	storage temperature		[3] -65	+150	°C
T_{amb}	ambient temperature	operating device	-40	+105	°C

[1] Pass level; Human Body Model (HBM) according to [Ref. 9 "JESD22-A114"](#).

[2] Pass level; latch-up testing according to [Ref. 10 "JESD78"](#) at maximum ambient temperature ($T_{amb(max)}$).

[3] According to the store and transport requirements (see [Ref. 13 "UM10569"](#)) the devices have to be stored at a temperature of +8 °C to +45 °C and a humidity of 25 % to 75 %.

12. Static characteristics

Table 20. Static characteristics
 $V_{DD} = 1.8\text{ V to }5.5\text{ V}; V_{SS} = 0\text{ V}; V_{LCD} = 2.5\text{ V to }8.0\text{ V}; T_{amb} = -40\text{ }^{\circ}\text{C to }+105\text{ }^{\circ}\text{C};$ unless otherwise specified.

Symbol	Parameter	Conditions	Min	Typ	Max	Unit
Supplies						
V _{DD}	supply voltage	V _{LCD} ≤ 6.5 V	1.8	-	5.5	V
		V _{LCD} > 6.5 V	2.5	-	5.5	V
V _{LCD}	LCD supply voltage	V _{DD} < 2.5 V	2.5	-	6.5	V
		V _{DD} ≥ 2.5 V	2.5	-	8.0	V
I _{DD}	supply current	f _{clk(ext)} = 1536 Hz	[1][2]	6	20	μA
		V _{DD} = 3.0 V; T _{amb} = 25 °C	-	2.7	-	μA
I _{DD(LCD)}	LCD supply current	f _{clk(ext)} = 1536 Hz	[1]	18	30	μA
		V _{DD(LCD)} = 3.0 V; T _{amb} = 25 °C	-	17.5	-	μA
Logic						
V _{IL}	LOW-level input voltage	on pins CLK, $\overline{\text{SYNC}}$, OSC, A0 to A2, SA0, SCL, SDA	V _{SS}	-	0.3V _{DD}	V
V _{IH}	HIGH-level input voltage	on pins CLK, $\overline{\text{SYNC}}$, OSC, A0 to A2, SA0, SCL, SDA	[4][5]	0.7V _{DD}	V _{DD}	V
I _{OL}	LOW-level output current	output sink current; V _{OL} = 0.4 V; V _{DD} = 5 V				
		on pins CLK and $\overline{\text{SYNC}}$	1	-	-	mA
		on pin SDA	3	-	-	mA
I _{OH(CLK)}	HIGH-level output current on pin CLK	output source current; V _{OH} = 4.6 V; V _{DD} = 5 V	1	-	-	mA
I _L	leakage current	V _I = V _{DD} or V _{SS} ; on pins CLK, SCL, SDA, A0 to A2 and SA0	-1	-	+1	μA
I _{L(OSC)}	leakage current on pin OSC	V _I = V _{DD}	-1	-	+1	μA
C _I	input capacitance		[6]	-	7	pF

Table 20. Static characteristics ...continued

$V_{DD} = 1.8\text{ V to }5.5\text{ V}$; $V_{SS} = 0\text{ V}$; $V_{LCD} = 2.5\text{ V to }8.0\text{ V}$; $T_{amb} = -40\text{ }^{\circ}\text{C to }+105\text{ }^{\circ}\text{C}$; unless otherwise specified.

Symbol	Parameter	Conditions	Min	Typ	Max	Unit
LCD outputs						
ΔV_O	output voltage variation	on pins BP0 to BP3 and S0 to S39	-100	-	+100	mV
R_O	output resistance	$V_{LCD} = 5\text{ V}$				
		on pins BP0 to BP3	-	1.5	-	k Ω
		on pins S0 to S39	-	6.0	-	k Ω

- [1] LCD outputs are open-circuit; inputs at V_{SS} or V_{DD} ; external clock with 50 % duty factor; I²C-bus inactive.
- [2] For typical values, see [Figure 26](#).
- [3] The I²C-bus interface of PCA8576F is 5 V tolerant.
- [4] When tested, I²C pins SCL and SDA have no diode to V_{DD} and may be driven to the V_I limiting values given in [Table 19](#) (see [Figure 25](#) as well).
- [5] Propagation delay of driver between clock (CLK) and LCD driving signals.
- [6] Periodically sampled, not 100 % tested.
- [7] Outputs measured one at a time.

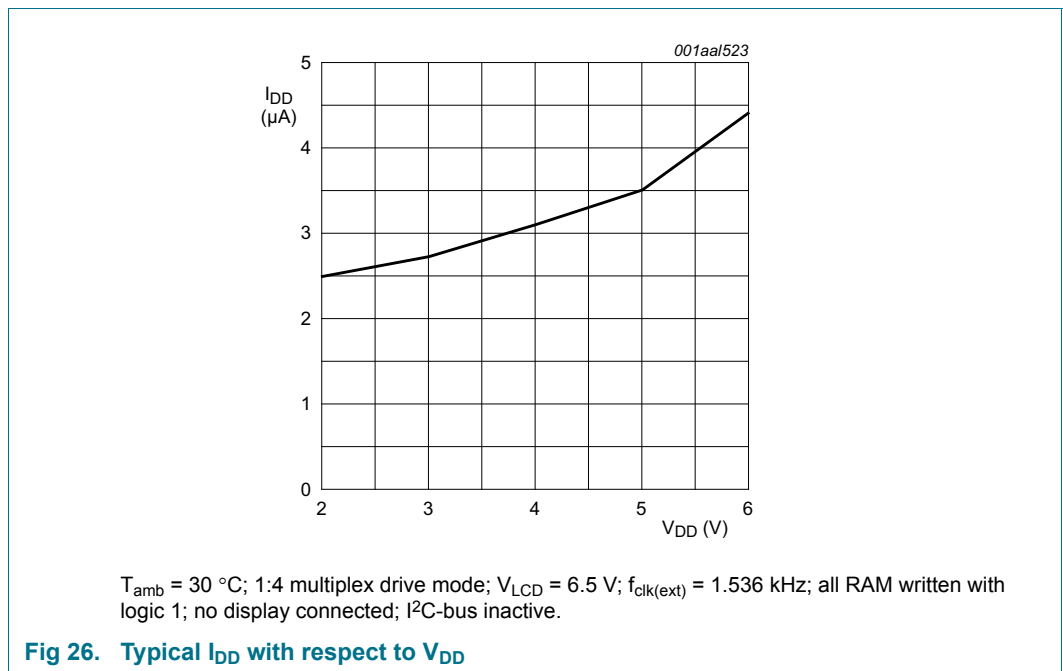

13. Dynamic characteristics

Table 21. Dynamic characteristics

$V_{DD} = 1.8\text{ V to }5.5\text{ V}$; $V_{SS} = 0\text{ V}$; $V_{LCD} = 2.5\text{ V to }8.0\text{ V}$; $T_{amb} = -40\text{ }^{\circ}\text{C to }+105\text{ }^{\circ}\text{C}$; unless otherwise specified.

Symbol	Parameter	Conditions	Min	Typ	Max	Unit
Clock						
$f_{\text{clk(int)}}$	internal clock frequency	[1]	3505	4800	6240	Hz
$f_{\text{clk(ext)}}$	external clock frequency		960	-	6720	Hz
f_{fr}	frame frequency	internal clock	146	200	260	Hz
		external clock	40	-	280	Hz
$t_{\text{clk(H)}}$	HIGH-level clock time		60	-	-	μs
$t_{\text{clk(L)}}$	LOW-level clock time		60	-	-	μs
Synchronization						
$t_{\text{PD(SYNC_N)}}$	$\overline{\text{SYNC}}$ propagation delay		-	30	-	ns
$t_{\text{SYNC_NL}}$	$\overline{\text{SYNC}}$ LOW time		1	-	-	μs
$t_{\text{PD(drv)}}$	driver propagation delay	$V_{\text{LCD}} = 5\text{ V}$ [2]	-	-	30	μs
I²C-bus[3]						
Pin SCL						
f_{SCL}	SCL clock frequency		-	-	400	kHz
t_{LOW}	LOW period of the SCL clock		1.3	-	-	μs
t_{HIGH}	HIGH period of the SCL clock		0.6	-	-	μs
Pin SDA						
$t_{\text{SU;DAT}}$	data set-up time		100	-	-	ns
$t_{\text{HD;DAT}}$	data hold time		0	-	-	ns
Pins SCL and SDA						
t_{BUF}	bus free time between a STOP and START condition		1.3	-	-	μs
$t_{\text{SU;STO}}$	set-up time for STOP condition		0.6	-	-	μs
$t_{\text{HD;STA}}$	hold time (repeated) START condition		0.6	-	-	μs
$t_{\text{SU;STA}}$	set-up time for a repeated START condition		0.6	-	-	μs
t_{r}	rise time of both SDA and SCL signals	$f_{\text{SCL}} = 400\text{ kHz}$	-	-	0.3	μs
		$f_{\text{SCL}} < 125\text{ kHz}$	-	-	1.0	μs
t_{f}	fall time of both SDA and SCL signals		-	-	0.3	μs
C_{b}	capacitive load for each bus line		-	-	400	pF
$t_{\text{w(spike)}}$	spike pulse width	on the I ² C-bus	-	-	50	ns

[1] Typical output duty factor: 50 % measured at the CLK output pin.

[2] Not tested in production.

[3] All timing values are valid within the operating supply voltage and ambient temperature range and are referenced to V_{IL} and V_{IH} with an input voltage swing of V_{SS} to V_{DD} .

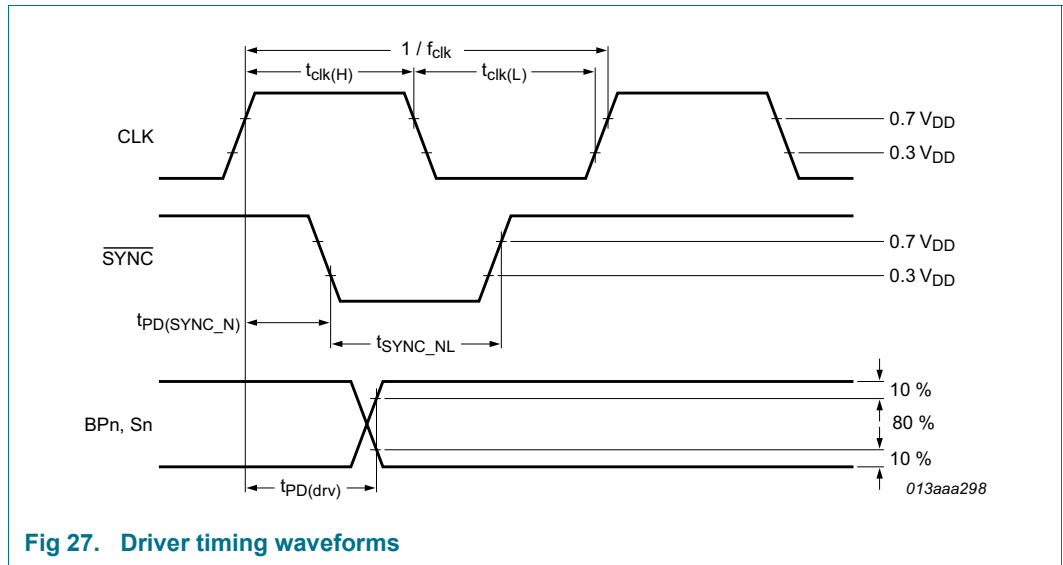

Fig 27. Driver timing waveforms

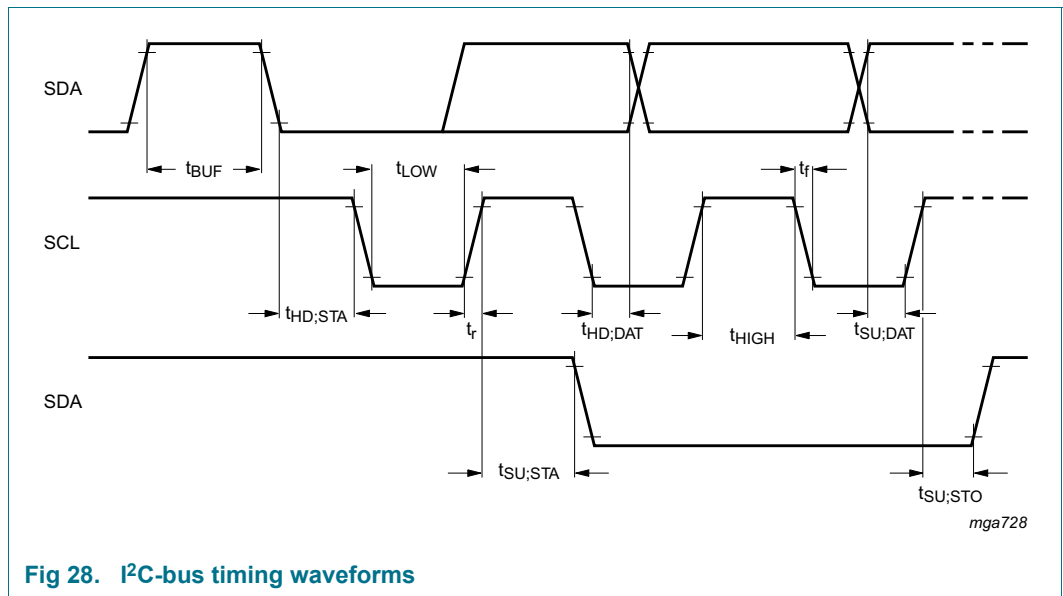

Fig 28. I²C-bus timing waveforms

14. Application information

14.1 Cascaded operation

In large display configurations, up to 16 PCA8576Fs can be differentiated on the same I²C-bus by using the 3-bit hardware subaddresses (A0, A1 and A2) and the programmable I²C-bus slave address (SA0).

Table 22. Addressing cascaded PCA8576F

Cluster	Bit SA0	Pin A2	Pin A1	Pin A0	Device
1	0	0	0	0	0
		0	0	1	1
		0	1	0	2
		0	1	1	3
		1	0	0	4
		1	0	1	5
		1	1	0	6
		1	1	1	7
2	1	0	0	0	8
		0	0	1	9
		0	1	0	10
		0	1	1	11
		1	0	0	12
		1	0	1	13
		1	1	0	14
		1	1	1	15

PCA8576Fs connected in cascade are synchronized to allow the backplane signals from only one device in the cascade to be shared. This arrangement is cost-effective in large LCD applications since the backplane outputs of only one device need to be through-plated to the backplane electrodes of the display. The other PCA8576F of the cascade contribute additional segment outputs. The backplanes can either be connected together to enhance the drive capability or some can be left open-circuit (such as the ones from the slave in [Figure 29](#)) or just some of the master and some of the slave will be taken to facilitate the layout of the display.

All PCA8576Fs connected in cascade are correctly synchronized by the automatically generated $\overline{\text{SYNC}}$ signal. The only time that $\overline{\text{SYNC}}$ is likely to be needed is if synchronization is lost accidentally, for example, by noise in adverse electrical environments, or if the LCD multiplex drive mode is changed in an application using several cascaded PCA8576Fs, as the drive mode cannot be changed on all of the cascaded devices simultaneously. $\overline{\text{SYNC}}$ can be either an input or an output signal; a $\overline{\text{SYNC}}$ output is implemented as an open-drain driver with an internal pull-up resistor. The PCA8576F asserts $\overline{\text{SYNC}}$ at the start of its last active backplane signal and monitors the $\overline{\text{SYNC}}$ line at all other times. If cascade synchronization is lost, it is restored by the first PCA8576F to assert $\overline{\text{SYNC}}$. The timing relationship between the backplane waveforms and the $\overline{\text{SYNC}}$ signal for each LCD drive mode is shown in [Figure 30](#).

The contact resistance between the $\overline{\text{SYNC}}$ on each cascaded device must be controlled. If the resistance is too high, the device is not able to synchronize properly; this is particularly applicable to chip-on-glass applications. The maximum $\overline{\text{SYNC}}$ contact resistance allowed for the number of devices in cascade is given in [Table 23](#).

Table 23. $\overline{\text{SYNC}}$ contact resistance

Number of devices	Maximum contact resistance
2	6 kΩ
3 to 5	2.2 kΩ
6 to 10	1.2 kΩ
10 to 16	700 Ω

[Figure 27](#) and [Figure 28](#) show the timing of the synchronization signals.

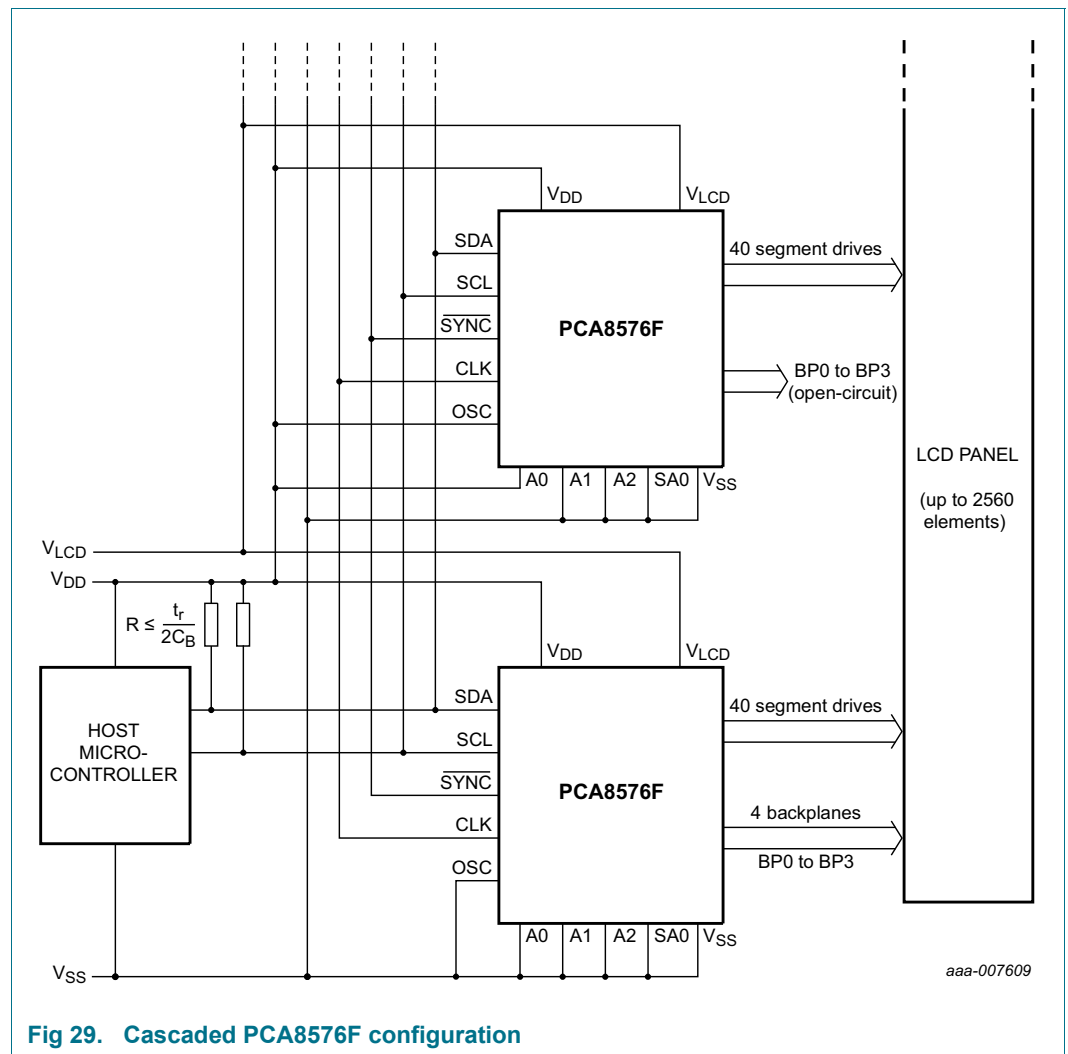
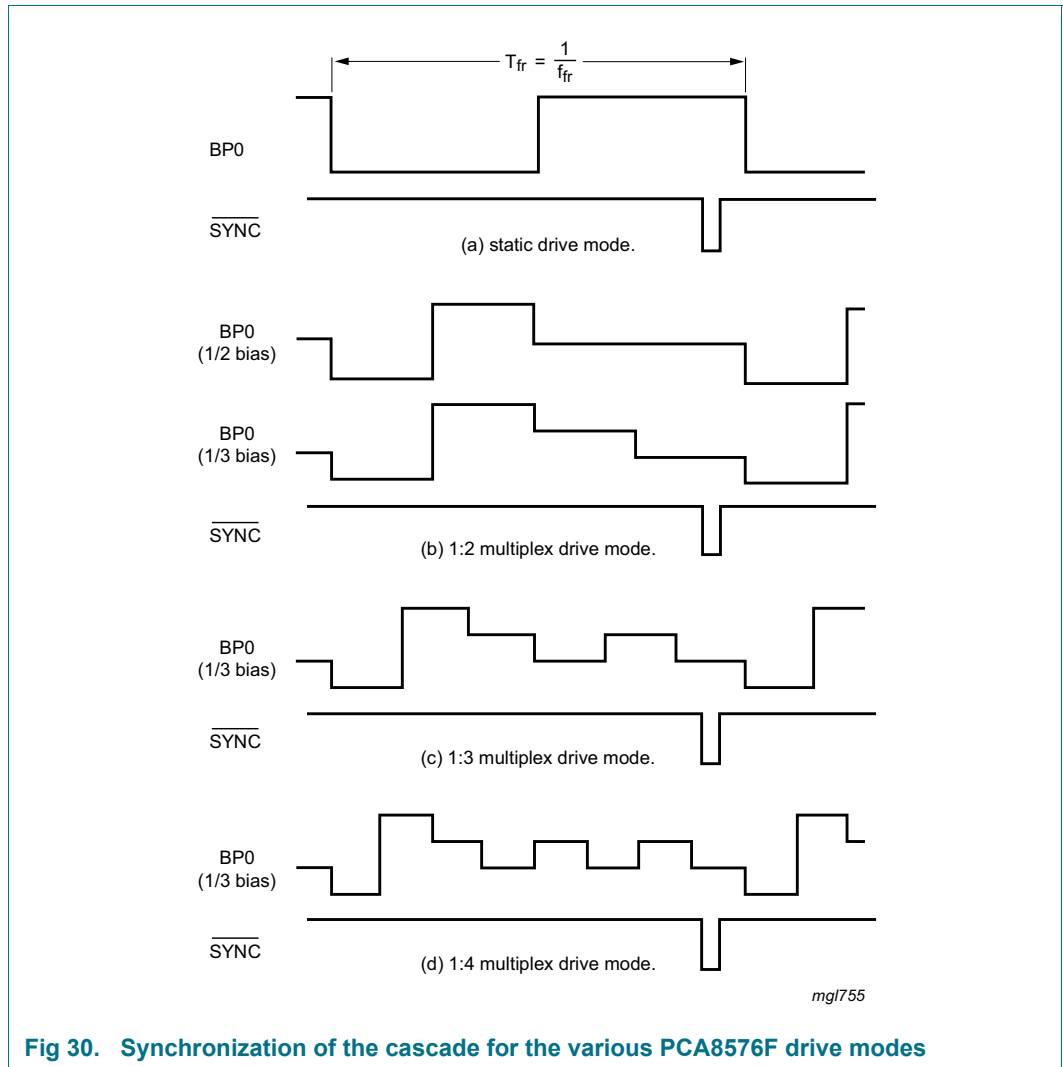

Fig 29. Cascaded PCA8576F configuration



15. Bare die outline

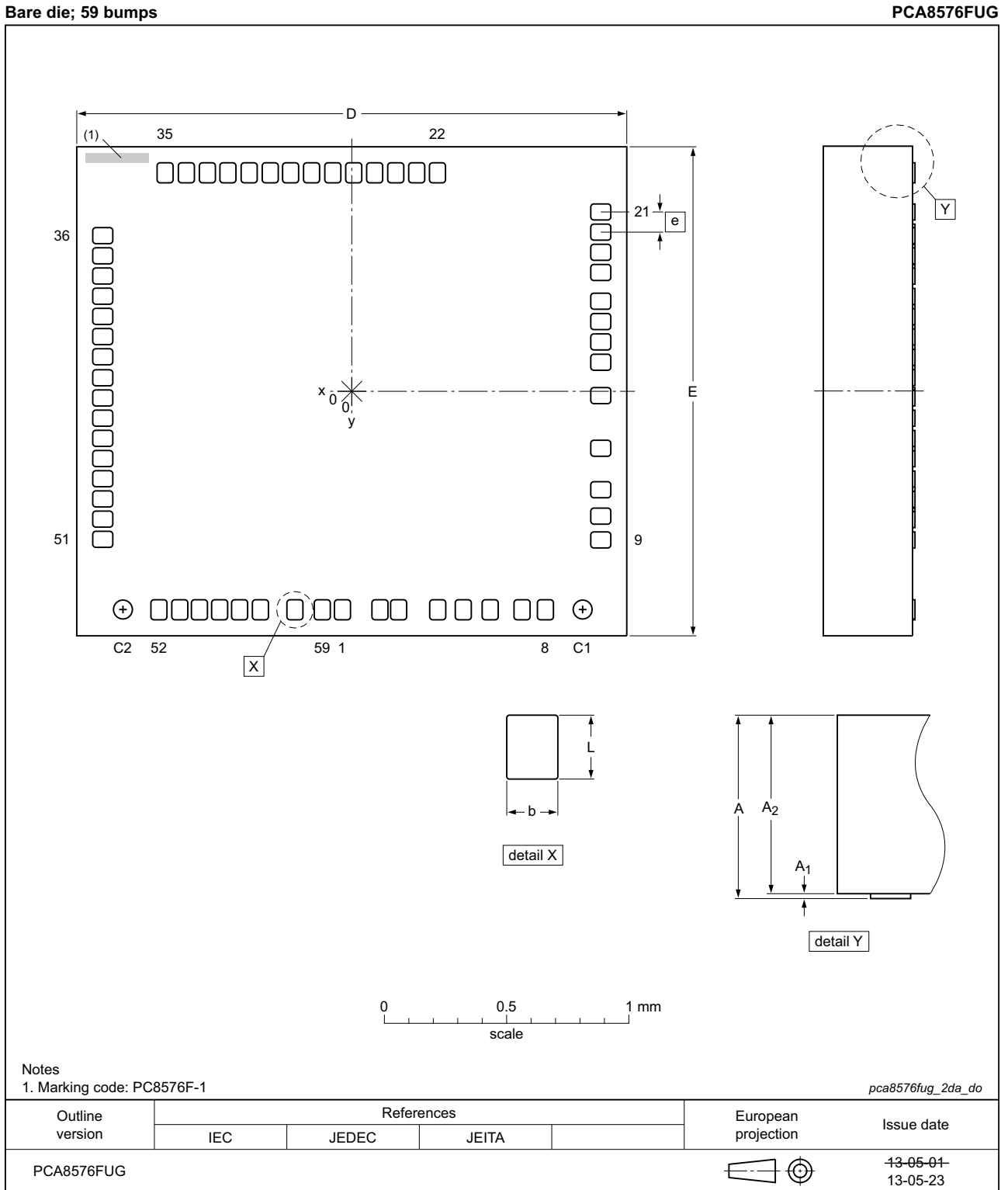

Fig 31. Bare die outline PCA8576FUG (for dimensions see Table 24)

Table 24. Dimensions of PCA8576FUG

Original dimensions are in mm.

Unit (mm)	A	A ₁	A ₂	b	D	E	e ^[1]	L
max	-	0.012	-	-	-	-	-	-
nom	0.40	0.015	0.381	0.052	2.2	2.0	-	0.077
min	-	0.018	-	-	-	-	0.072	-

[1] Dimension not drawn to scale.

Table 25. Bump location for PCA8576FUGAll x/y coordinates represent the position of the center of each pad with respect to the center (x/y = 0) of the chip (see [Figure 2](#), and [Figure 31](#)).

Symbol	Pad	X (μm)	Y (μm)	Description
SDA	1	-34.38	-876.6	I ² C-bus serial data input/output
SCL	2	109.53	-876.6	I ² C-bus serial clock input
SCL	3	181.53	-876.6	
SYNC	4	365.58	-876.6	cascade synchronization input/output
CLK	5	469.08	-876.6	external clock input/output
V _{DD}	6	577.08	-876.6	supply voltage
OSC	7	740.88	-876.6	internal oscillator enable input
A0	8	835.83	-876.6	subaddress inputs
A1	9	1005.48	-630.9	
A2	10	1005.48	-513.9	
SA0	11	1005.48	-396.9	I ² C-bus address input; bit 0
V _{SS}	12	1005.48	-221.4	ground supply voltage
V _{LCD}	13	1005.48	10.71	LCD supply voltage
BP0	14	1005.48	156.51	LCD backplane outputs
BP2	15	1005.48	232.74	
BP1	16	1005.48	308.97	
BP3	17	1005.48	385.2	
S0	18	1005.48	493.2	LCD segment outputs
S1	19	1005.48	565.2	
S2	20	1005.48	637.2	
S3	21	1005.48	709.2	
S4	22	347.22	876.6	
S5	23	263.97	876.6	
S6	24	180.72	876.6	
S7	25	97.47	876.6	
S8	26	14.22	876.6	
S9	27	-69.03	876.6	
S10	28	-152.28	876.6	
S11	29	-235.53	876.6	
S12	30	-318.78	876.6	
S13	31	-402.03	876.6	

Table 25. Bump location for PCA8576FUG ...continued

All x/y coordinates represent the position of the center of each pad with respect to the center (x/y = 0) of the chip (see [Figure 2](#), and [Figure 31](#)).

Symbol	Pad	X (μm)	Y (μm)	Description
S14	32	-485.28	876.6	LCD segment outputs
S15	33	-568.53	876.6	
S16	34	-651.78	876.6	
S17	35	-735.03	876.6	
S18	36	-1005.5	625.59	
S19	37	-1005.5	541.62	
S20	38	-1005.5	458.19	
S21	39	-1005.5	374.76	
S22	40	-1005.5	291.33	
S23	41	-1005.5	207.9	
S24	42	-1005.5	124.47	
S25	43	-1005.5	41.04	
S26	44	-1005.5	-42.39	
S27	45	-1005.5	-125.8	
S28	46	-1005.5	-209.3	
S29	47	-1005.5	-292.7	
S30	48	-1005.5	-376.1	
S31	49	-1005.5	-459.5	
S32	50	-1005.5	-543	
S33	51	-1005.5	-625.6	
S34	52	-735.03	-876.6	
S35	53	-663.03	-876.6	
S36	54	-591.03	-876.6	
S37	55	-519.03	-876.6	
S38	56	-447.03	-876.6	
S39	57	-375.03	-876.6	
SDA	58	-196.38	-876.6	I ² C-bus serial data input/output
SDA	59	-106.38	-876.6	

Table 26. Alignment marks

All x/y coordinates represent the position of the center of each alignment mark with respect to the center (x/y = 0) of the chip (see [Figure 2](#), and [Figure 31](#)).

Symbol	Location		Dimension
	X (μm)	Y (μm)	Diameter (μm)
C1	930.42	-870.3	72
C2	-829.98	-870.3	72

16. Handling information

All input and output pins are protected against ElectroStatic Discharge (ESD) under normal handling. When handling Metal-Oxide Semiconductor (MOS) devices ensure that all normal precautions are taken as described in *JESD625-A*, *IEC 61340-5* or equivalent standards.

17. Packing information

17.1 Tray information

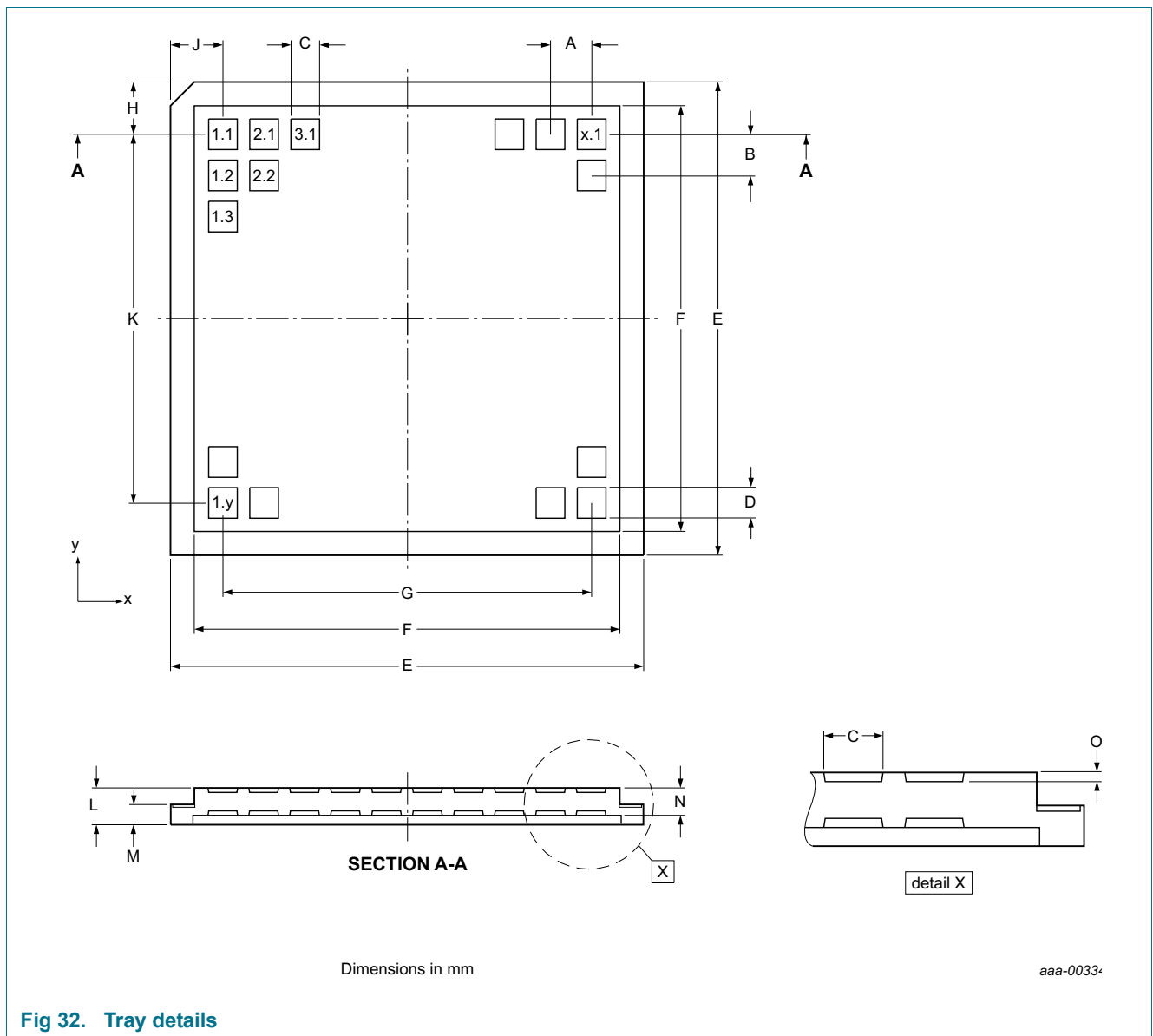
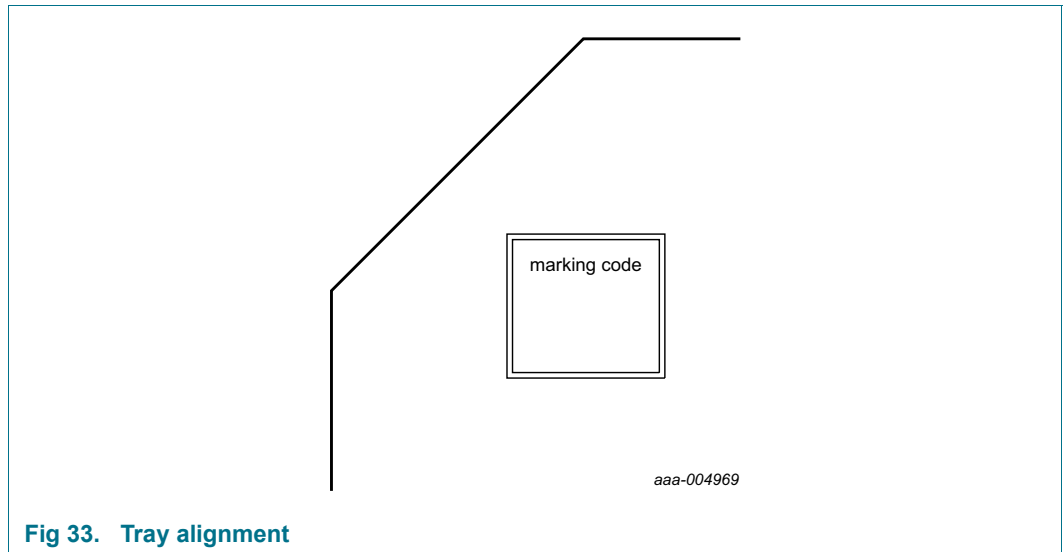

Fig 32. Tray details

Table 27. Description of tray details

Tray details are shown in [Figure 32](#).

Tray details													
Dimensions													
A	B	C	D	E	F	G	H	J	K	L	M	N	Unit
3.6	3.6	2.36	2.11	50.8	45.72	39.6	5.6	5.6	39.6	3.96	2.18	2.49	mm
Number of pockets													
x direction							y direction						
12							12						



18. Appendix

18.1 LCD segment driver selection

Table 28. Selection of LCD segment drivers

Type name	Number of elements at MUX							V _{DD} (V)	V _{LCD} (V)	f _{fr} (Hz)	V _{LCD} (V) charge pump	V _{LCD} (V) temperature compensat.	T _{amb} (°C)	Interface	Package	AEC- Q100
	1:1	1:2	1:3	1:4	1:6	1:8	1:9									
PCA8561AHN ^[5]	18	36	54	72	-	-	-	1.8 to 5.5	1.8 to 5.5	32 to 256 ^[1]	N	N	-40 to 105	I ² C	HVQFN32	Y
PCA8561BHN ^[5]	18	36	54	72	-	-	-	1.8 to 5.5	1.8 to 5.5	32 to 256 ^[1]	N	N	-40 to 105	SPI	HVQFN32	Y
PCF8566TS	24	48	72	96	-	-	-	2.5 to 6	2.5 to 6	69	N	N	-40 to 85	I ² C	VSO40	N
PCF85162T	32	64	96	128	-	-	-	1.8 to 5.5	2.5 to 6.5	82	N	N	-40 to 85	I ² C	TSSOP48	N
PCA85162T	32	64	96	128	-	-	-	1.8 to 5.5	2.5 to 8	110	N	N	-40 to 95	I ² C	TSSOP48	Y
PCA85262ATT	32	64	96	128	-	-	-	1.8 to 5.5	2.5 to 8	200	N	N	-40 to 105	I ² C	TSSOP48	Y
PCF8551ATT ^[5]	36	72	108	144	-	-	-	1.8 to 5.5	1.8 to 5.5	32 to 128 ^[1]	N	N	-40 to 85	I ² C	TSSOP48	N
PCF8551BTT ^[5]	36	72	108	144	-	-	-	1.8 to 5.5	1.8 to 5.5	32 to 128 ^[1]	N	N	-40 to 85	SPI	TSSOP48	N
PCA8551ATT ^[5]	36	72	108	144	-	-	-	1.8 to 5.5	1.8 to 5.5	32 to 256 ^[1]	N	N	-40 to 105	I ² C	TSSOP48	Y
PCA8551BTT ^[5]	36	72	108	144	-	-	-	1.8 to 5.5	1.8 to 5.5	32 to 256 ^[1]	N	N	-40 to 105	SPI	TSSOP48	Y
PCF85176T	40	80	120	160	-	-	-	1.8 to 5.5	2.5 to 6.5	82	N	N	-40 to 85	I ² C	TSSOP56	N
PCA85176T	40	80	120	160	-	-	-	1.8 to 5.5	2.5 to 8	110	N	N	-40 to 95	I ² C	TSSOP56	Y
PCA85276ATT	40	80	120	160	-	-	-	1.8 to 5.5	2.5 to 8	200	N	N	-40 to 105	I ² C	TSSOP56	Y
PCF85176H	40	80	120	160	-	-	-	1.8 to 5.5	2.5 to 6.5	82	N	N	-40 to 85	I ² C	TQFP64	N
PCA85176H	40	80	120	160	-	-	-	1.8 to 5.5	2.5 to 8	82	N	N	-40 to 95	I ² C	TQFP64	Y
PCF8553ATT ^[5]	40	80	120	160	-	-	-	1.8 to 5.5	1.8 to 5.5	32 to 128 ^[1]	N	N	-40 to 85	I ² C	TSSOP56	N
PCF8553BTT ^[5]	40	80	120	160	-	-	-	1.8 to 5.5	1.8 to 5.5	32 to 128 ^[1]	N	N	-40 to 85	SPI	TSSOP56	N
PCA8553ATT ^[5]	40	80	120	160	-	-	-	1.8 to 5.5	1.8 to 5.5	32 to 256 ^[1]	N	N	-40 to 105	I ² C	TSSOP56	Y
PCA8553BTT ^[5]	40	80	120	160	-	-	-	1.8 to 5.5	1.8 to 5.5	32 to 256 ^[1]	N	N	-40 to 105	SPI	TSSOP56	Y
PCA8546ATT	-	-	-	176	-	-	-	1.8 to 5.5	2.5 to 9	60 to 300 ^[1]	N	N	-40 to 95	I ² C	TSSOP56	Y
PCA8546BTT	-	-	-	176	-	-	-	1.8 to 5.5	2.5 to 9	60 to 300 ^[1]	N	N	-40 to 95	SPI	TSSOP56	Y
PCA8547AHT ^[5]	44	88	-	176	-	-	-	1.8 to 5.5	2.5 to 9	60 to 300 ^[1]	Y	Y ^[3]	-40 to 95	I ² C	TQFP64	Y
PCA8547BHT ^[5]	44	88	-	176	-	-	-	1.8 to 5.5	2.5 to 9	60 to 300 ^[1]	Y	Y ^[3]	-40 to 95	SPI	TQFP64	Y
PCF85134HL	60	120	180	240	-	-	-	1.8 to 5.5	2.5 to 6.5	82	N	N	-40 to 85	I ² C	LQFP80	N
PCA85134H	60	120	180	240	-	-	-	1.8 to 5.5	2.5 to 8	82	N	N	-40 to 95	I ² C	LQFP80	Y

Table 28. Selection of LCD segment drivers ...continued

Type name	Number of elements at MUX							V _{DD} (V)	V _{LCD} (V)	f _{fr} (Hz)	V _{LCD} (V) charge pump	V _{LCD} (V) temperature compensat.	T _{amb} (°C)	Interface	Package	AEC- Q100
	1:1	1:2	1:3	1:4	1:6	1:8	1:9									
PCA8543AHL	60	120	-	240	-	-	-	2.5 to 5.5	2.5 to 9	60 to 300 ^[1]	Y	Y	-40 to 105	I ² C	LQFP80	Y
PCF8545ATT	-	-	-	176	252	320	-	1.8 to 5.5	2.5 to 5.5	60 to 300 ^[1]	N	N	-40 to 85	I ² C	TSSOP56	N
PCF8545BTT	-	-	-	176	252	320	-	1.8 to 5.5	2.5 to 5.5	60 to 300 ^[1]	N	N	-40 to 85	SPI	TSSOP56	N
PCF8536AT ^[4]	-	-	-	176	252	320	-	1.8 to 5.5	2.5 to 9	60 to 300 ^[1]	N	N	-40 to 85	I ² C	TSSOP56	N
PCF8536BT ^[4]	-	-	-	176	252	320	-	1.8 to 5.5	2.5 to 9	60 to 300 ^[1]	N	N	-40 to 85	SPI	TSSOP56	N
PCA8536AT ^[4]	-	-	-	176	252	320	-	1.8 to 5.5	2.5 to 9	60 to 300 ^[1]	N	N	-40 to 95	I ² C	TSSOP56	Y
PCA8536BT ^[4]	-	-	-	176	252	320	-	1.8 to 5.5	2.5 to 9	60 to 300 ^[1]	N	N	-40 to 95	SPI	TSSOP56	Y
PCF8537AH	44	88	-	176	276	352	-	1.8 to 5.5	2.5 to 9	60 to 300 ^[1]	Y	Y ^[3]	-40 to 85	I ² C	TQFP64	N
PCF8537BH	44	88	-	176	276	352	-	1.8 to 5.5	2.5 to 9	60 to 300 ^[1]	Y	Y ^[3]	-40 to 85	SPI	TQFP64	N
PCA8537AH	44	88	-	176	276	352	-	1.8 to 5.5	2.5 to 9	60 to 300 ^[1]	Y	Y ^[3]	-40 to 95	I ² C	TQFP64	Y
PCA8537BH	44	88	-	176	276	352	-	1.8 to 5.5	2.5 to 9	60 to 300 ^[1]	Y	Y ^[3]	-40 to 95	SPI	TQFP64	Y
PCA9620H	60	120	-	240	320	480	-	2.5 to 5.5	2.5 to 9	60 to 300 ^[1]	Y	Y ^[3]	-40 to 105	I ² C	LQFP80	Y
PCA9620U	60	120	-	240	320	480	-	2.5 to 5.5	2.5 to 9	60 to 300 ^[1]	Y	Y ^[3]	-40 to 105	I ² C	bare die	Y
PCF8552DUG ^[5]	36	72	108	144	-	-	-	1.8 to 5.5	1.8 to 5.5	32 to 128 ^[1]	N	N	-40 to 85	I ² C, SPI	bare die	N
PCA8552DUG ^[5]	36	72	108	144	-	-	-	1.8 to 5.5	1.8 to 5.5	32 to 256 ^[1]	N	N	-40 to 105	I ² C, SPI	bare die	Y
PCF8576DU	40	80	120	160	-	-	-	1.8 to 5.5	2.5 to 6.5	77	N	N	-40 to 85	I ² C	bare die	N
PCF8576EUG	40	80	120	160	-	-	-	1.8 to 5.5	2.5 to 6.5	77	N	N	-40 to 85	I ² C	bare die	N
PCA8576FUG	40	80	120	160	-	-	-	1.8 to 5.5	2.5 to 8	200	N	N	-40 to 105	I ² C	bare die	Y
PCF85133U	80	160	240	320	-	-	-	1.8 to 5.5	2.5 to 6.5	82, 110 ^[2]	N	N	-40 to 85	I ² C	bare die	N
PCA85133U	80	160	240	320	-	-	-	1.8 to 5.5	2.5 to 8	82, 110 ^[2]	N	N	-40 to 95	I ² C	bare die	Y
PCA85233U	80	160	240	320	-	-	-	1.8 to 5.5	2.5 to 8	150, 220 ^[2]	N	N	-40 to 105	I ² C	bare die	Y
PCA8530DUG ^[5]	102	204	-	408	-	-	-	2.5 to 5.5	4 to 12	45 to 300 ^[1]	Y	Y ^[3]	-40 to 105	I ² C, SPI	bare die	Y
PCF85132U	160	320	480	640	-	-	-	1.8 to 5.5	1.8 to 8	60 to 90 ^[1]	N	N	-40 to 85	I ² C	bare die	N
PCA85132U	160	320	480	640	-	-	-	1.8 to 5.5	1.8 to 8	60 to 90 ^[1]	N	N	-40 to 95	I ² C	bare die	Y
PCA85232U	160	320	480	640	-	-	-	1.8 to 5.5	1.8 to 8	117 to 176 ^[1]	N	N	-40 to 95	I ² C	bare die	Y
PCF8538UG	102	204	-	408	612	816	918	2.5 to 5.5	4 to 12	45 to 300 ^[1]	Y	Y ^[3]	-40 to 85	I ² C, SPI ^[2]	bare die	N
PCA8538UG	102	204	-	408	612	816	918	2.5 to 5.5	4 to 12	45 to 300 ^[1]	Y	Y ^[3]	-40 to 105	I ² C, SPI ^[2]	bare die	Y

[1] Can be selected by command.

[2] Can be selected by pin configuration.

- [3] Extra feature: Temperature sensor.
- [4] Extra feature: 6 PWM channels.
- [5] In development.

PCA8576F

Product data sheet

All information provided in this document is subject to legal disclaimers.

Rev. 1 — 22 November 2013

© NXP B.V. 2013. All rights reserved.

49 of 57

19. Abbreviations

Table 29. Abbreviations

Acronym	Description
CDM	Charged-Device Model
CMOS	Complementary Metal-Oxide Semiconductor
HBM	Human Body Model
ITO	Indium Tin Oxide
LCD	Liquid Crystal Display
LSB	Least Significant Bit
MM	Machine Model
MSB	Most Significant Bit
MSL	Moisture Sensitivity Level
PCB	Printed Circuit Board
RAM	Random Access Memory
RMS	Root Mean Square
SCL	Serial CLock line
SDA	Serial DATa line
SMD	Surface Mount Device

20. References

- [1] **AN10170** — Design guidelines for COG modules with NXP monochrome LCD drivers
- [2] **AN10365** — Surface mount reflow soldering description
- [3] **AN10706** — Handling bare die
- [4] **AN10853** — ESD and EMC sensitivity of IC
- [5] **AN11267** — EMC and system level ESD design guidelines for LCD drivers
- [6] **IEC 60134** — Rating systems for electronic tubes and valves and analogous semiconductor devices
- [7] **IEC 61340-5** — Protection of electronic devices from electrostatic phenomena
- [8] **IPC/JEDEC J-STD-020D** — Moisture/Reflow Sensitivity Classification for Nonhermetic Solid State Surface Mount Devices
- [9] **JESD22-A114** — Electrostatic Discharge (ESD) Sensitivity Testing Human Body Model (HBM)
- [10] **JESD78** — IC Latch-Up Test
- [11] **JESD625-A** — Requirements for Handling Electrostatic-Discharge-Sensitive (ESDS) Devices
- [12] **UM10204** — I²C-bus specification and user manual
- [13] **UM10569** — Store and transport requirements

21. Revision history

Table 30. Revision history

Document ID	Release date	Data sheet status	Change notice	Supersedes
PCA8576F v.1	20131122	Product data sheet	-	-

22. Legal information

22.1 Data sheet status

Document status ^{[1][2]}	Product status ^[3]	Definition
Objective [short] data sheet	Development	This document contains data from the objective specification for product development.
Preliminary [short] data sheet	Qualification	This document contains data from the preliminary specification.
Product [short] data sheet	Production	This document contains the product specification.

[1] Please consult the most recently issued document before initiating or completing a design.

[2] The term 'short data sheet' is explained in section "Definitions".

[3] The product status of device(s) described in this document may have changed since this document was published and may differ in case of multiple devices. The latest product status information is available on the Internet at URL <http://www.nxp.com>.

22.2 Definitions

Draft — The document is a draft version only. The content is still under internal review and subject to formal approval, which may result in modifications or additions. NXP Semiconductors does not give any representations or warranties as to the accuracy or completeness of information included herein and shall have no liability for the consequences of use of such information.

Short data sheet — A short data sheet is an extract from a full data sheet with the same product type number(s) and title. A short data sheet is intended for quick reference only and should not be relied upon to contain detailed and full information. For detailed and full information see the relevant full data sheet, which is available on request via the local NXP Semiconductors sales office. In case of any inconsistency or conflict with the short data sheet, the full data sheet shall prevail.

Product specification — The information and data provided in a Product data sheet shall define the specification of the product as agreed between NXP Semiconductors and its customer, unless NXP Semiconductors and customer have explicitly agreed otherwise in writing. In no event however, shall an agreement be valid in which the NXP Semiconductors product is deemed to offer functions and qualities beyond those described in the Product data sheet.

22.3 Disclaimers

Limited warranty and liability — Information in this document is believed to be accurate and reliable. However, NXP Semiconductors does not give any representations or warranties, expressed or implied, as to the accuracy or completeness of such information and shall have no liability for the consequences of use of such information. NXP Semiconductors takes no responsibility for the content in this document if provided by an information source outside of NXP Semiconductors.

In no event shall NXP Semiconductors be liable for any indirect, incidental, punitive, special or consequential damages (including - without limitation - lost profits, lost savings, business interruption, costs related to the removal or replacement of any products or rework charges) whether or not such damages are based on tort (including negligence), warranty, breach of contract or any other legal theory.

Notwithstanding any damages that customer might incur for any reason whatsoever, NXP Semiconductors' aggregate and cumulative liability towards customer for the products described herein shall be limited in accordance with the *Terms and conditions of commercial sale* of NXP Semiconductors.

Right to make changes — NXP Semiconductors reserves the right to make changes to information published in this document, including without limitation specifications and product descriptions, at any time and without notice. This document supersedes and replaces all information supplied prior to the publication hereof.

Suitability for use in automotive applications — This NXP Semiconductors product has been qualified for use in automotive applications. Unless otherwise agreed in writing, the product is not designed, authorized or warranted to be suitable for use in life support, life-critical or safety-critical systems or equipment, nor in applications where failure or malfunction of an NXP Semiconductors product can reasonably be expected to result in personal injury, death or severe property or environmental damage. NXP Semiconductors and its suppliers accept no liability for inclusion and/or use of NXP Semiconductors products in such equipment or applications and therefore such inclusion and/or use is at the customer's own risk.

Applications — Applications that are described herein for any of these products are for illustrative purposes only. NXP Semiconductors makes no representation or warranty that such applications will be suitable for the specified use without further testing or modification.

Customers are responsible for the design and operation of their applications and products using NXP Semiconductors products, and NXP Semiconductors accepts no liability for any assistance with applications or customer product design. It is customer's sole responsibility to determine whether the NXP Semiconductors product is suitable and fit for the customer's applications and products planned, as well as for the planned application and use of customer's third party customer(s). Customers should provide appropriate design and operating safeguards to minimize the risks associated with their applications and products.

NXP Semiconductors does not accept any liability related to any default, damage, costs or problem which is based on any weakness or default in the customer's applications or products, or the application or use by customer's third party customer(s). Customer is responsible for doing all necessary testing for the customer's applications and products using NXP Semiconductors products in order to avoid a default of the applications and the products or of the application or use by customer's third party customer(s). NXP does not accept any liability in this respect.

Limiting values — Stress above one or more limiting values (as defined in the Absolute Maximum Ratings System of IEC 60134) will cause permanent damage to the device. Limiting values are stress ratings only and (proper) operation of the device at these or any other conditions above those given in the Recommended operating conditions section (if present) or the Characteristics sections of this document is not warranted. Constant or repeated exposure to limiting values will permanently and irreversibly affect the quality and reliability of the device.

Terms and conditions of commercial sale — NXP Semiconductors products are sold subject to the general terms and conditions of commercial sale, as published at <http://www.nxp.com/profile/terms>, unless otherwise agreed in a valid written individual agreement. In case an individual agreement is concluded only the terms and conditions of the respective agreement shall apply. NXP Semiconductors hereby expressly objects to applying the customer's general terms and conditions with regard to the purchase of NXP Semiconductors products by customer.

No offer to sell or license — Nothing in this document may be interpreted or construed as an offer to sell products that is open for acceptance or the grant, conveyance or implication of any license under any copyrights, patents or other industrial or intellectual property rights.

Export control — This document as well as the item(s) described herein may be subject to export control regulations. Export might require a prior authorization from competent authorities.

Translations — A non-English (translated) version of a document is for reference only. The English version shall prevail in case of any discrepancy between the translated and English versions.

Bare die — All die are tested on compliance with their related technical specifications as stated in this data sheet up to the point of wafer sawing and are handled in accordance with the NXP Semiconductors storage and transportation conditions. If there are data sheet limits not guaranteed, these will be separately indicated in the data sheet. There are no post-packing tests performed on individual die or wafers.

NXP Semiconductors has no control of third party procedures in the sawing, handling, packing or assembly of the die. Accordingly, NXP Semiconductors assumes no liability for device functionality or performance of the die or systems after third party sawing, handling, packing or assembly of the die. It is the responsibility of the customer to test and qualify their application in which the die is used.

All die sales are conditioned upon and subject to the customer entering into a written die sale agreement with NXP Semiconductors through its legal department.

22.4 Trademarks

Notice: All referenced brands, product names, service names and trademarks are the property of their respective owners.

I²C-bus — logo is a trademark of NXP B.V.

23. Contact information

For more information, please visit: <http://www.nxp.com>

For sales office addresses, please send an email to: salesaddresses@nxp.com

24. Tables

Table 1.	Ordering information	2
Table 2.	Ordering options	2
Table 3.	Marking codes	2
Table 4.	Pin description	5
Table 5.	Definition of PCA8576F commands	6
Table 6.	C bit description	6
Table 7.	Mode-set command bit description	6
Table 8.	Load-data-pointer command bit description	7
Table 9.	Device-select command bit description	7
Table 10.	Bank-select command bit description	8
Table 11.	Blink-select command bit description	8
Table 12.	Selection of possible display configurations	10
Table 13.	Biassing characteristics	11
Table 14.	Mapping of output pins and corresponding output signals with respect to the multiplex driving mode	20
Table 15.	Standard RAM filling in 1:3 multiplex drive mode	23
Table 16.	Entire RAM filling by rewriting in 1:3 multiplex drive mode	23
Table 17.	Blinking frequencies	27
Table 18.	I ² C slave address byte	30
Table 19.	Limiting values	34
Table 20.	Static characteristics	35
Table 21.	Dynamic characteristics	37
Table 22.	Addressing cascaded PCA8576F	39
Table 23.	SYNC contact resistance	40
Table 24.	Dimensions of PCA8576FUG	43
Table 25.	Bump location for PCA8576FUG	43
Table 26.	Alignment marks	44
Table 27.	Description of tray details	46
Table 28.	Selection of LCD segment drivers	47
Table 29.	Abbreviations	50
Table 30.	Revision history	52

25. Figures

Fig 1.	Block diagram of PCA8576F	3
Fig 2.	Pinning diagram for PCA8576FUG (bare die)	4
Fig 3.	Format of command byte	6
Fig 4.	Example of displays suitable for PCA8576F	9
Fig 5.	Typical system configuration	10
Fig 6.	Electro-optical characteristic: relative transmission curve of the liquid	13
Fig 7.	Static drive mode waveforms	14
Fig 8.	Waveforms for the 1:2 multiplex drive mode with $\frac{1}{2}$ bias	15
Fig 9.	Waveforms for the 1:2 multiplex drive mode with $\frac{1}{3}$ bias	16
Fig 10.	Waveforms for the 1:3 multiplex drive mode with $\frac{1}{3}$ bias	17
Fig 11.	Waveforms for the 1:4 multiplex drive mode with $\frac{1}{3}$ bias	18
Fig 12.	Display RAM bit map	20
Fig 13.	Relationship between LCD layout, drive mode, display RAM filling order and display data transmitted over the I ² C-bus	21
Fig 14.	Display RAM filling order in static drive mode	22
Fig 15.	Display RAM filling order in 1:2 multiplex drive mode	22
Fig 16.	Display RAM filling order in 1:4 multiplex drive mode	24
Fig 17.	RAM banks in static and multiplex driving mode 1:2	25
Fig 18.	Bank selection	26
Fig 19.	Example of the Bank-select command with multiplex drive mode 1:2	26
Fig 20.	Bit transfer	28
Fig 21.	Definition of START and STOP conditions	28
Fig 22.	System configuration	29
Fig 23.	Acknowledgement of the I ² C-bus	29
Fig 24.	I ² C-bus protocol	31
Fig 25.	Device protection circuits	32
Fig 26.	Typical I _{DD} with respect to V _{DD}	36
Fig 27.	Driver timing waveforms	38
Fig 28.	I ² C-bus timing waveforms	38
Fig 29.	Cascaded PCA8576F configuration	40
Fig 30.	Synchronization of the cascade for the various PCA8576F drive modes	41
Fig 31.	Bare die outline PCA8576FUG (for dimensions see Table 24)	42
Fig 32.	Tray details	45
Fig 33.	Tray alignment	46

26. Contents

1	General description	1	7.11	Display controller	27
2	Features and benefits	1	8	Characteristics of the I²C-bus	28
3	Ordering information	2	8.1	Bit transfer	28
3.1	Ordering options	2	8.1.1	START and STOP conditions	28
4	Marking	2	8.2	System configuration	28
5	Block diagram	3	8.3	Acknowledge	29
6	Pinning information	4	8.4	I ² C-bus controller	30
6.1	Pinning	4	8.5	Input filters	30
6.2	Pin description	5	8.6	I ² C-bus protocol	30
7	Functional description	6	9	Internal circuitry	32
7.1	Commands of PCA8576F	6	10	Safety notes	33
7.1.1	Command: mode-set	6	11	Limiting values	34
7.1.2	Command: load-data-pointer	7	12	Static characteristics	35
7.1.3	Command: device-select	7	13	Dynamic characteristics	37
7.1.4	Command: bank-select	8	14	Application information	39
7.1.5	Command: blink-select	8	14.1	Cascaded operation	39
7.2	Initialization	8	15	Bare die outline	42
7.3	Possible display configurations	9	16	Handling information	45
7.4	LCD voltage	10	17	Packing information	45
7.4.1	LCD bias generator	10	17.1	Tray information	45
7.4.2	LCD voltage selector	11	18	Appendix	47
7.4.2.1	Electro-optical performance	12	18.1	LCD segment driver selection	47
7.4.3	LCD drive mode waveforms	14	19	Abbreviations	50
7.4.3.1	Static drive mode	14	20	References	51
7.4.3.2	1:2 Multiplex drive mode	15	21	Revision history	52
7.4.3.3	1:3 Multiplex drive mode	17	22	Legal information	53
7.4.3.4	1:4 Multiplex drive mode	18	22.1	Data sheet status	53
7.5	Oscillator	19	22.2	Definitions	53
7.5.1	Internal clock	19	22.3	Disclaimers	53
7.5.2	External clock	19	22.4	Trademarks	54
7.5.3	Timing and frame frequency	19	23	Contact information	54
7.6	Segment outputs	19	24	Tables	55
7.7	Backplane outputs	19	25	Figures	56
7.8	Display register	20	26	Contents	57
7.9	Display RAM	20			
7.9.1	RAM filling in static drive mode	22			
7.9.2	RAM filling in 1:2 multiplex drive mode	22			
7.9.3	RAM filling in 1:3 multiplex drive mode	23			
7.9.4	RAM filling in 1:4 multiplex drive mode	23			
7.9.5	Data pointer	24			
7.9.6	Subaddress counter	24			
7.9.7	Writing over the RAM address boundary	25			
7.9.8	Bank selection	25			
7.9.8.1	RAM bank switching	25			
7.9.8.2	Output bank selector	26			
7.9.8.3	Input bank selector	27			
7.10	Blinking	27			

Please be aware that important notices concerning this document and the product(s) described herein, have been included in section 'Legal information'.