

NPN Transistors

2SD1742A

■ Features

- High forward current transfer ratio h_{FE} which has satisfactory linearity
- Low collector to emitter saturation voltage $V_{CE(sat)}$
- Complementary to 2SB1172A

■ Absolute Maximum Ratings $T_a = 25^\circ\text{C}$

Parameter	Symbol	Rating	Unit	
Collector - Base Voltage	V_{CB0}	80	V	
Collector - Emitter Voltage	V_{CE0}	80		
Emitter - Base Voltage	V_{EB0}	6		
Collector Current - Continuous	I_C	3	A	
Collector Current - Pulse	I_{CP}	5		
Collector Power Dissipation	P_C	$T_c=25^\circ\text{C}$	15	W
		$T_a=25^\circ\text{C}$	1.3	
Junction Temperature	T_J	150	$^\circ\text{C}$	
Storage Temperature Range	T_{stg}	-55 to 150		

■ Electrical Characteristics $T_a = 25^\circ\text{C}$

Parameter	Symbol	Test Conditions	Min	Typ	Max	Unit
Collector- base breakdown voltage	V_{CB0}	$I_C = 100 \mu\text{A}$, $I_E = 0$	80			V
Collector- emitter breakdown voltage	V_{CE0}	$I_C = 30 \text{ mA}$, $I_B = 0$	80			
Emitter - base breakdown voltage	V_{EB0}	$I_E = 100 \mu\text{A}$, $I_C = 0$	6			
Collector-base cut-off current	I_{CBO}	$V_{CB} = 80 \text{ V}$, $I_E = 0$			0.1	mA
Collector-emitter cutoff current	I_{CES}	$V_{CE} = 80 \text{ V}$, $V_{BE} = 0$			200	μA
Collector-emitter cutoff current	I_{CEO}	$V_{CE} = 60 \text{ V}$, $I_B = 0$			300	
Emitter cut-off current	I_{EBO}	$V_{EB} = 6 \text{ V}$, $I_C = 0$			0.1	mA
Collector-emitter saturation voltage	$V_{CE(sat)}$	$I_C = 3 \text{ A}$, $I_B = 375 \text{ mA}$			1.2	V
Base - emitter saturation voltage	$V_{BE(sat)}$	$I_C = 3 \text{ A}$, $I_B = 375 \text{ mA}$			1.2	
Base - emitter voltage	V_{BE}	$V_{CE} = 4 \text{ V}$, $I_C = 3 \text{ A}$			1.8	
DC current gain	h_{FE}	$V_{CE} = 4 \text{ V}$, $I_C = 1 \text{ A}$	70		250	
		$V_{CE} = 4 \text{ V}$, $I_C = 3 \text{ A}$	10			
Turn-ON Time	t_{on}	$I_C = 1 \text{ A}$, $I_{B1} = 0.1 \text{ A}$, $I_{B2} = -0.1 \text{ A}$, $V_{CC} = 50 \text{ V}$		0.5		μs
Storage Time	t_{stg}			2.5		
Fall Time	t_f				0.4	
Transition frequency	f_T	$V_{CE} = 10 \text{ V}$, $I_C = 500 \text{ mA}$, $f = 10 \text{ MHz}$		30		MHz

■ Classification of $h_{FE}(1)$

Type	2SD1742A-Q	2SD1742A-P
Range	70-150	120-250

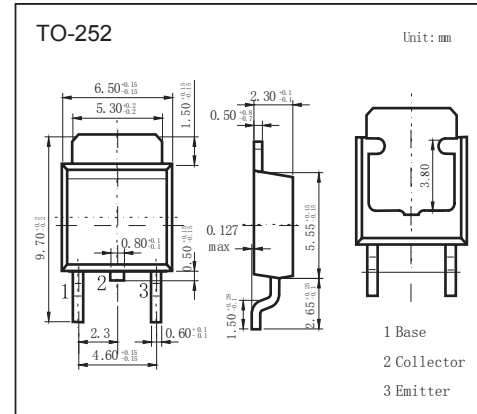

NPN Transistors

2SD1742A

■ Typical Characteristics

