

# BelaSigna R281

## Always-Listening, Voice Trigger Solution

### Introduction

BelaSigna<sup>®</sup> R281 is an ultra-low-power voice trigger solution for a wide range of consumer electronic devices. In a typical application BelaSigna R281 is “always listening” and will detect a single, user-trained trigger phrase, asserting a wake-up signal when this trigger phrase is detected.

“Always-listening” key phrase detection with an average power consumption of less than 300  $\mu$ W (not including the power consumption of the microphone) preserves Standby battery life.

BelaSigna R281 is an ultra-miniature solution that is available in both a 5 mm x 5 mm QFN32 package (488AM) and a 2.42 mm x 2.74 mm WLCSP package (available soon). It can be designed onto a single layer PCB with 4 mil routing and with a minimal amount of external components.

An external, I<sup>2</sup>C host controller is required to configure the device for operation.

### Key Features

#### Proven Ultra-Low-Power Digital Signal Processing (DSP) Technology

- Audio DSP Technology Originally Developed for Hearing Aids  
Offers the Required Computational Power at Extremely Low Current Consumption
- < 300  $\mu$ W Average Current Consumption (not including microphone)

#### Mixed-Signal System-on-Chip (SoC)

- Audio-grade, Analog Input with Onboard Pre-amplifier
- Built-in, Regulated Voltages Including Onboard Microphone Bias (1 V or 2 V) for Power Efficient Operation
- Supports Analog or Digital Microphone Input

#### Interfaces and Peripherals

- I<sup>2</sup>C-based Device Configuration and Control
- GPIO Wake Signal
- Internal Oscillator

#### Applications

- Mobile Phones
- Tablets
- Portable Electronic Devices
- Wearables
- Toys



ON Semiconductor<sup>®</sup>

[www.onsemi.com](http://www.onsemi.com)

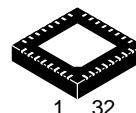

QFN32  
CASE 488AM

### MARKING DIAGRAM

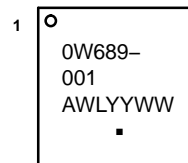

0W689-001 = Specific Device Code

A = Assembly Location

WL = Wafer Lot

YY = Year

WW = Work Week

■ = Pb-Free Package

### ORDERING INFORMATION

See detailed ordering and shipping information in the package dimensions section on page 10 of this data sheet.

# BelaSigna R281

## Figures and Data

**Table 1. ABSOLUTE MAXIMUM RATINGS**

Parameter	Symbol	Min	Max	Units
Input Voltage on any Digital Pin		-0.3	3.8	V
Input Voltage on any Analog Pin		-0.3	3.8	V
Input Voltage on any Supply Pin		-0.3	3.8	V
Current on any Digital Pin			±5	mA
Current on any Analog Pin			±10	mA

Stresses exceeding those listed in the Maximum Ratings table may damage the device. If any of these limits are exceeded, device functionality should not be assumed, damage may occur and reliability may be affected.

**Table 2. RECOMMENDED OPERATING CONDITIONS**

Parameter	Symbol	Min	Typ	Max	Units
Power Supply Applied to VBAT	VBAT	1.75	1.8	QFN	3.63
				WLCSP	1.98
Power Supply Applied to VDDO	VDDO	1.75	1.8	3.63	V
Internal Oscillator Clock Frequency		1	2.56	20	MHz
Ambient Operating Temperature Range	Ta	-40		85	°C

**Table 3. ESD AND LATCH-UP CHARACTERISTICS**

Parameter	Conditions	Max	Units
ESD – Human Body Model	JEDEC JS – 001 – 2010, all pins	2000	V
ESD – Charged Device Model	JESD22 – C101 – E, all pins	750	V
ESD – Machine Model	JESE22 – A115 – C, all pins	250	V
Latch – Up	JEDEC STD – 78, all pins	±100	mA

## Electrical Performance Specifications

### Typical Values

Unless otherwise noted, Typ values specify the typical values based on design and characterization data under normal operating conditions. Normal operating conditions include a supply voltage (VBAT) of 1.8 V and an operating temperature of 25°C. For specific blocks, the details of the normal operation conditions are described in their respective sections.

### Minimum and Maximum Values

Unless otherwise noted, Min and Max values specify the designed range or measurement range and are guaranteed by design and/or characterization.

Min and Max values specified may be based on factory production test limits, design, or characterization data.

### Normal Operating Conditions

Unless otherwise noted, normal operating conditions indicate an ambient temperature Ta = 25°C and a supply voltage VBAT = 1.8 V. VDDD and VDDA are calibrated to their preset factory calibration settings and correspond to their respective Typ values. VDDO is powered externally at 1.8 V. No external loads are applied to digital I/O or analog pins.

**Table 4. SYSTEM DC ELECTRICAL CHARACTERISTICS**

Typical operating conditions (Ta = 25°C, VBAT=VDDO=1.8 V, VDDD=1.4 V) unless otherwise noted

Parameter	Symbol	Conditions	Min	Typ	Max	Units
Average Run Mode Current	IDD	VBAT=VDDA=1.8 V, charge pump disabled Assumes a ratio of speech present versus quiet environment of 20/80		170		µA

# BelaSigna R281

**Table 5. DIGITAL I/O PINS (I2C, WAKE\_UP, DMIC) DC ELECTRICAL CHARACTERISTICS**

Typical operating conditions (Ta = 25°C, VDDO = 1.8 V, Pull-up/Pull-down Enabled) unless otherwise noted

Parameter	Symbol	Conditions	Min	Typ	Max	Units	
VDDO Supply Voltage Range	VDDO		1.25	1.8	3.63	V	
Output Low Level	V <sub>ol</sub>	I <sub>ol</sub> = 4 mA		0	0.2 x VDDO	V	
Output High Level	V <sub>oh</sub>	I <sub>oh</sub> = -4 mA	0.8 x VDDO	VDDO		V	
Input Low Level	V <sub>il</sub>			0	0.2 x VDDO	V	
Input High Level	V <sub>ih</sub>		0.8 x VDDO	VDDO		V	
Pull-Up Resistance	R <sub>pu</sub>	Non-I <sup>2</sup> C	VDDO = 1.8 V	80	122	160	kΩ
			VDDO = 3.3 V	30	48	60	
		I <sup>2</sup> C (strong/weak)	VDDO = 1.8 V	0.8 / 8	1 / 10	1.2 / 12	
			VDDO = 3.3 V	0.8 / 8	1 / 10	1.2 / 12	
Pull-Down Resistance	R <sub>pd</sub>	VDDO = 1.8 V	120	168	210	kΩ	
		VDDO = 3.3 V	30	60	80		
Pin Capacitance	C <sub>pd</sub>			5		pF	
Maximum Output Current	I <sub>ol</sub> , I <sub>oh</sub>				± 4	mA	
Input Leakage Current	I <sub>l</sub>				± 1	μA	

**Table 6. VDDA REGULATOR DC & AC ELECTRICAL CHARACTERISTICS**

Typical operating conditions (Ta = 25°C), unless otherwise noted

Parameter	Symbol	Conditions	Min	Typ	Max	Units
Output Voltage	VDDA	CL = 1 μF	1.8	1.98	2.0	V
Load Current					4	mA
Load Regulation				5		mV/mA
Line Regulation				20		mV/V
PSRR		@ 1 kHz unloaded	20			dB

**Table 7. VREG REGULATOR DC & AC ELECTRICAL CHARACTERISTICS**

Typical operating conditions (Ta = 25°C), unless otherwise noted

Parameter	Symbol	Conditions	Min	Typ	Max	Units
Output Voltage	VREG	CL = 1 μF	0.95	1.0	1.05	V
Load Current					2	mA
Load Regulation					20	mV/mA
Line Regulation					5	mV/V
PSRR		@ 1 kHz unloaded	40			dB

**Table 8. VDDD REGULATOR DC & AC ELECTRICAL CHARACTERISTICS**

Typical operating conditions (Ta = 25°C), unless otherwise noted

Parameter	Symbol	Conditions	Min	Typ	Max	Units
Output Voltage	VDDD	CL = 1 μF	1.2	1.4	1.7	V
Load Current					15	mA
Load Regulation					10	mV/mA
Line Regulation					20	mV/V
PSRR		@ 1 kHz unloaded	20			dB

# BelaSigna R281

## System Diagrams

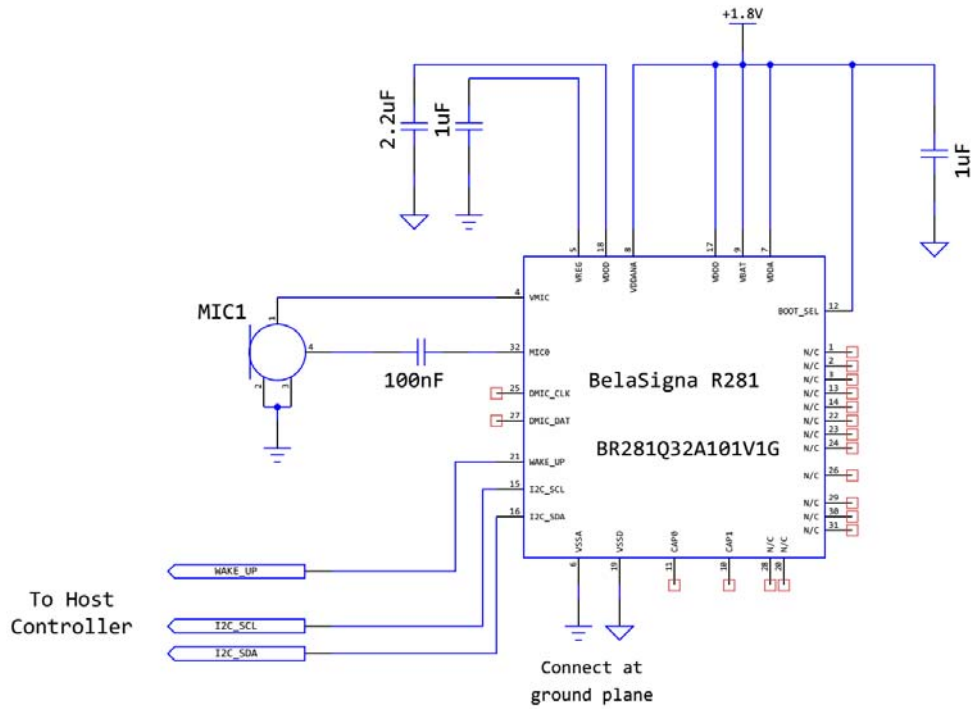

Figure 1. BelaSigna R281 System Diagram (Analog Microphone, VBAT = 1.8 V)

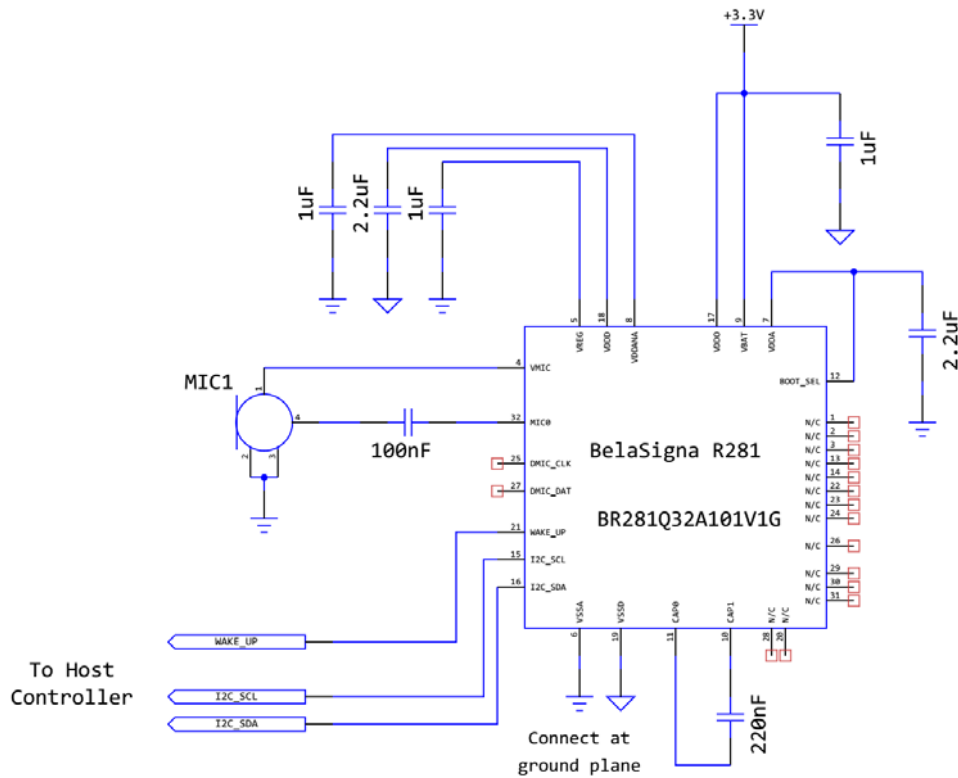

Figure 2. BelaSigna R281 System Diagram (Analog Microphone, VBAT = 3.3 V)

# BelaSigna R281

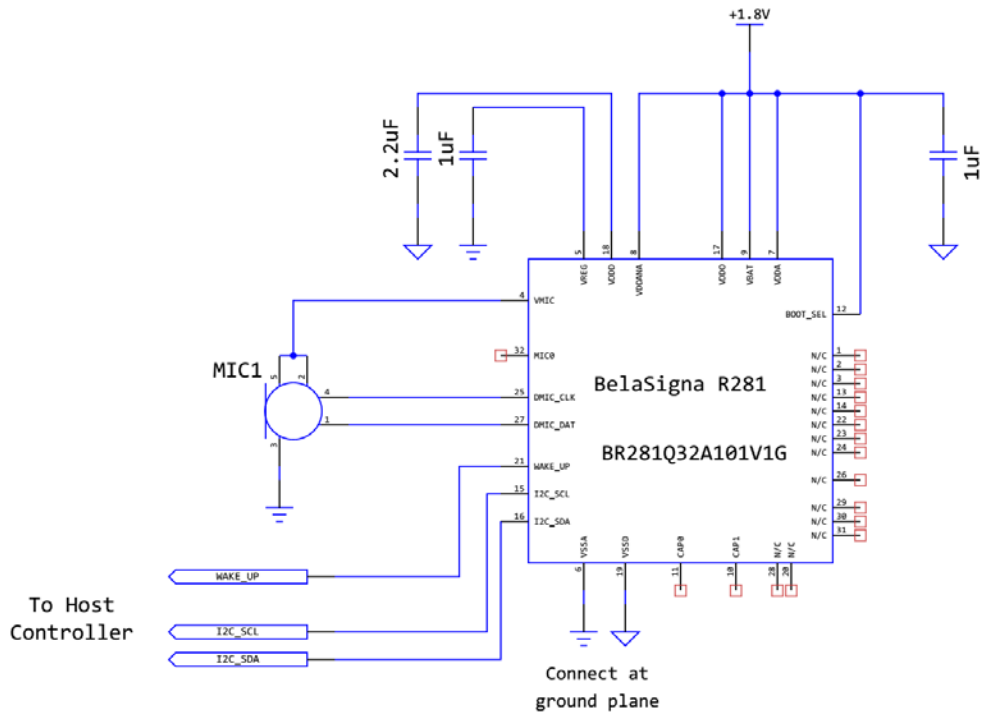

Figure 3. BelaSigna R281 System Diagram (Digital Microphone, VBAT = 1.8 V)

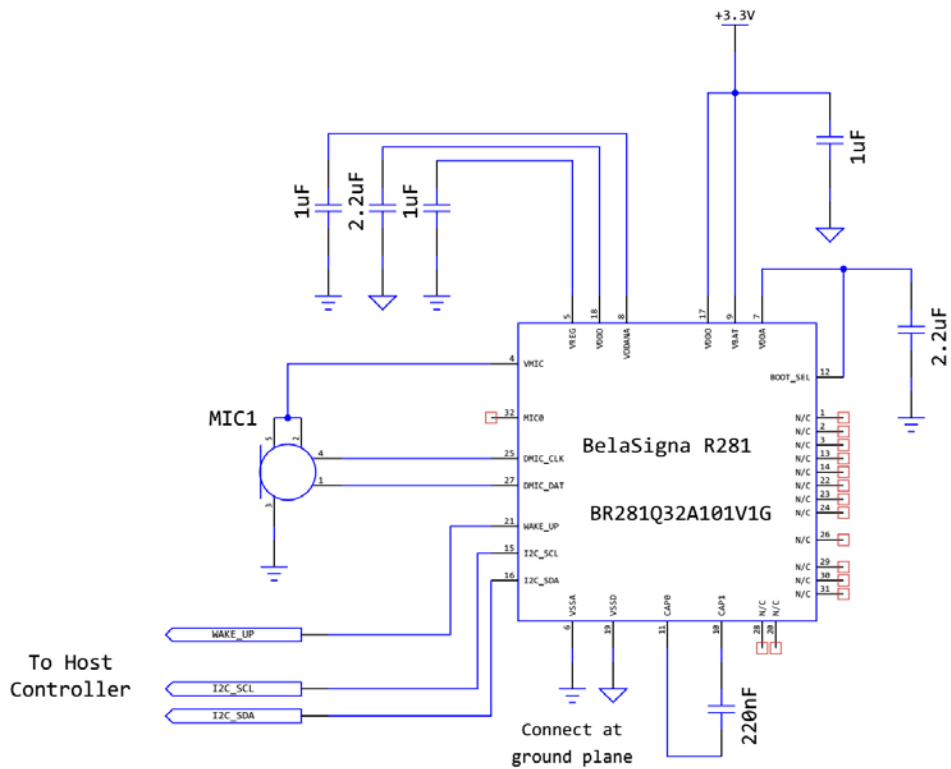

Figure 4. BelaSigna R281 System Diagram (Digital Microphone, VBAT = 3.3 V)

# BelaSigna R281

## Description of Operation

Efficient implementation of the trigger phrase recognition algorithm is accomplished through the use of three processing units running concurrently. In addition to the main DSP core performing system configuration and signal processing, an input/output processor continuously collects frames of input speech signals which are analyzed by a highly optimized frequency domain co-processor.

There are two main modes of operation: Recognition Mode and Training Mode.

## Recognition Mode

When in Recognition Mode, the entire system remains in an extremely low-power, “always-on” state continuously listening for speech. When speech is detected, the algorithm proceeds to extract features from the collected audio data, comparing these features to a known set of data computed during the training process. If the features appear to be similar enough to the trained feature data, a match is indicated on the WAKE\_UP pin.

Once the feature extraction and comparison is complete, the system returns to its original low-power state, once again waiting until speech is detected.

## Training Mode

Before BelaSigna R281 can be placed into Recognition Mode, it must be trained. Training involves recording and analyzing three utterances of a *trigger phrase*. A trigger phrase can be any collection of words or sounds, in any language, up to a maximum length of approximately 1.5 seconds.

When speaking a given phrase, a human will naturally say the same phrase subtly different each time. Having multiple instances of the same phrase, each slightly different, helps to make the matching algorithm more robust.

Training must be performed in a quiet environment, or the trigger phrase match results in Recognition Mode will be unpredictable. BelaSigna R281 is placed into Training Mode by issuing an appropriate SetMode command via I<sup>2</sup>C. The algorithm stores relevant feature data from the three separate utterances of the trigger phrase, also known as *training templates*.

Once training is complete, the training templates can be read from memory and stored offline. This template data can then be loaded into memory in the event of a power cycle and the device can be placed directly into Recognition Mode, thus avoiding the need to re-train the device. This same procedure can be used to recognize multiple trigger phrases, provided they have each been individually trained and stored offline. Only one trigger phrase can be active at any one time.

Refer to AND9267/D for more information on the different modes, as well as a description of the I<sup>2</sup>C host control protocol.

## Initial Power-On State

When BelaSigna R281 is powered on, the device will perform a brief initialization procedure and then wait for a connection to be made from an external host via I<sup>2</sup>C. At this point, the host controller must connect to BelaSigna R281 and load its memory with the algorithm binary image, as well as the training template data. Once this has been completed, the device can be put into Recognition Mode. If no training template data is available (e.g. the training procedure has never been performed), then BelaSigna R281 must be placed into Training Mode and the training procedure performed before entering Recognition Mode.

Whenever power is removed from the device, the contents of memory are lost and must be re-loaded.

For more information refer to AND9267/D.

# BelaSigna R281

## System Performance

### Recognition Rate

Performance has been measured in various noise conditions and is shown in Figure 5. Tests were performed in a sound isolation booth with a series of pre-recorded trigger and non-trigger phrases playing continuously, mixed

with varying levels of noise. Recognition rate is 100% in a quiet environment (no noise playing). The system was trained in a quiet environment. In all cases, the false trigger rate (the number of times the system triggered on a non-trigger phrase) was 0%.

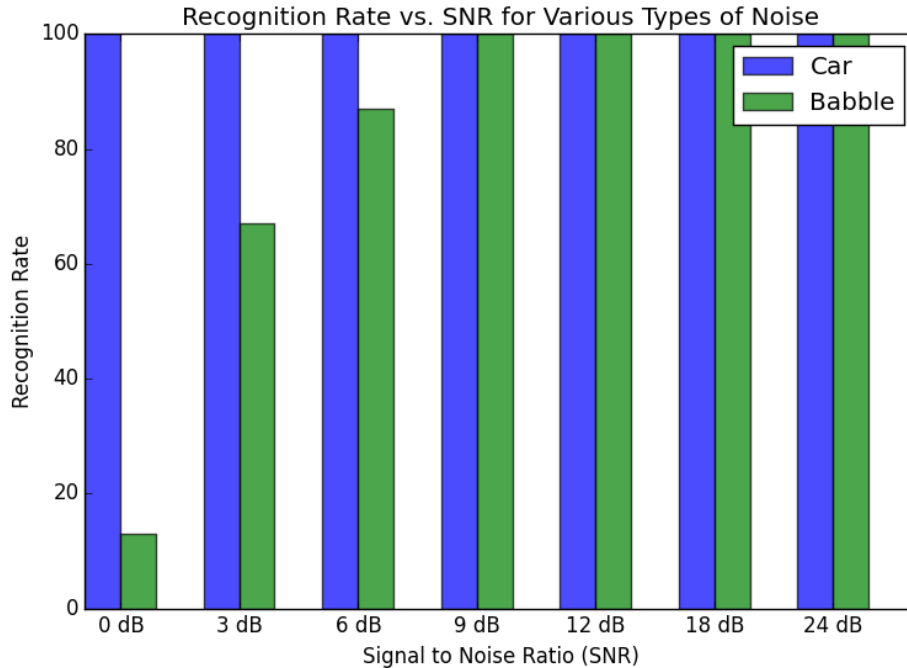

Figure 5. Recognition Rate Versus SNR

### Current Consumption

Average current consumption was also measured with the device operating in a pure noise environment with no speech present. The results are presented in Table 9.

Table 9. AVERAGE CURRENT CONSUMPTION

Condition	Average Current Consumption (uA), VBAT = 1.8 V
Quiet Environment	160
Babble Noise	170

\*Not including microphone current consumption

### Single User Operation

Because BelaSigna R281 performs recognition based on a training procedure performed by a specific individual, recognition of the trigger phrase is effectively “single-user”. Only the person who trained the system (or an individual with an extremely similar voice print) will be able to reliably trigger the device.

### Digital Interfaces

#### Wake Up Pin

The Wake Up pin is a digital output (referenced to VDDO) which is used to indicate that the trigger phrase was detected. It is intended to be connected to a digital input of an external

host, and its behavior (active high versus active low and duration) is configurable via I<sup>2</sup>C.

For more information refer to AND9267/D.

#### Boot Select Pin

This pin is reserved for future purpose and must be connected to VDDA.

#### Inter – IC Communication (I<sup>2</sup>C) Interface

The I<sup>2</sup>C interface is an industry-standard interface that can be used for high-speed transmission of data between BelaSigna R281 and an external device. The interface operates at speeds up to 100 Kbit/sec, and always operates in slave mode at an address of 0x62.

# BelaSigna R281

## Digital Microphone (DMIC) Interface

The digital microphone interface provides a means of interfacing a digital microphone to the system instead of an analog microphone. When the device is configured to use a digital microphone input instead of an analog microphone input (the default), an appropriate clock is output on the DMIC\_CLK pin and device accepts PDM signals from a

digital microphone on the DMIC\_DAT input pin. A separate algorithm binary image is available supporting a digital microphone input.

Figure 6 shows the timing of the DMIC interface. For more information refer to AND9267/D.

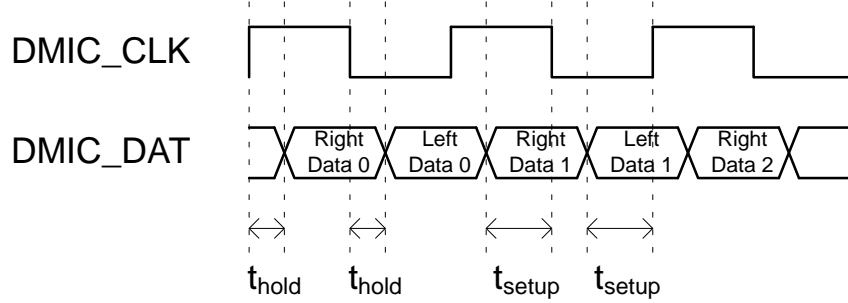

Figure 6. DMIC Timing Diagram



# BelaSigna R281

## Mechanical Information and Circuit Design Guidelines

BelaSigna R281 is available in two packages:

1. A 5 x 5 mm QFN32 package
2. A 2.42 x 2.74 mm ultra-miniature wafer-level chip scale package (WLCSP)

**Table 10. PIN DESCRIPTION**

QFN32 Pin #	WLCSP Ball Index	Name	Description	Pad Type	Pull
9	A1	VBAT	Main power supply	P	
6	F2	VSSA	Analog ground	P	
8	N/A	VDDANA	Analog supply voltage (output), capacitor to VSSA, or connected to VBAT (max. 1.98 V)	A	
5	E1	VREG	Analog supply voltage (output), capacitor to VSSA	A	
11	B2	CAP0	Charge pump capacitor to CAP1	A	
10	D2	CAP1	Charge pump capacitor to CAP0	A	
7	C1	VDDA	Analog supply voltage (output), capacitor to VSSA, or connected to VBAT (max. 1.98 V)	P	
4	H2	VMIC	Analog microphone supply output	A	
1	I1	N/A	No connection	NC	
32	K1	MIC0	Analog microphone input	AI	
31	M1	N/A	No connection	NC	
30	L2	N/A	No connection	NC	
29	M3	N/A	No connection	NC	
3	K3	N/A	No connection	NC	
2	J2	N/A	No connection	NC	
14	A3	N/A	No connection	NC	
13	C3	N/A	No connection	NC	
12	E3	BOOT_SEL	Boot selection (always connect to VDDA)	AI	
17	A5	VDDO	Digital I/O supply, capacitor to VSSD, typically connected to VBAT	P	
18	E5	VDDD	Digital supply, capacitor to VSSD	P	
19	C5	VSSD	Digital core and I/O ground, connect to VSSA on PCB	P	
28	I3	N/A	No connection	NC	
21	K5	WAKE_UP	Wake up signal (output)	DIO	
22	I5	N/A	No connection	NC	
23	H4	N/A	No connection	NC	
24	F4	N/A	No connection	NC	
26	J4	N/A	No connection	NC	
27	L4	DMIC_DAT	Digital microphone data input (optional)	DIO	
15	B4	I2C_SCL	I <sup>2</sup> C clock	DIO	PU
16	D4	I2C_SDA	I <sup>2</sup> C data	DIO	PU (Note 1)
25	M5	DMIC_CLK	Digital microphone clock (optional)	DIO	PU (Note 2)
20	G3	N/A	No connection	NC	

1. The value of the I<sup>2</sup>C pull-ups is 10 K
2. Pull-up is disabled when the DMIC interface is enabled.

### Legend:

Type: A = analog; D = digital; I = input; O = output; P = power; NC = not connected

Pull: PU = pull up; PD = pull down

All digital pads have a Schmitt trigger input

# BelaSigna R281

## Reflow Information

The reflow profile depends on the equipment that is used for the re-flow and the assembly that is being re-flowed. Information from JEDEC Standard 22-A113D and J-STD-020D.01 can be used as a guideline.

## Electrostatic Discharge (ESD) Device

CAUTION: ESD sensitive device. Permanent damage may occur on devices subjected to high-energy electrostatic discharges. Proper ESD precautions in handling, packaging and testing are recommended to avoid performance degradation or loss of functionality.

## Ordering Information

To order BelaSigna R281, please contact your account manager and ask for part number BR281Q32A101V1G.

## Chip Identification

Chip identification information can be retrieved using the GetChipID I<sup>2</sup>C command. The key identifier components and values are as follows for the different package options:

Refer to AND9267/D for more details regarding supported I<sup>2</sup>C commands.

## Company or Product Inquiries

For more information about ON Semiconductor Sales products or services visit our website at <http://onsemi.com>.

## ORDERING INFORMATION

Part Number	Package Option	Chip ID
BR281Q32A101V1G	QFN32	0x5000

# BelaSigna R281

## PACKAGE DIMENSIONS

QFN32 5x5, 0.5P  
CASE 488AM  
ISSUE A

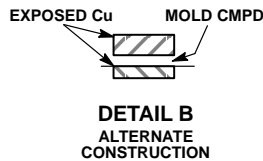
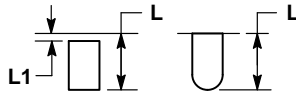
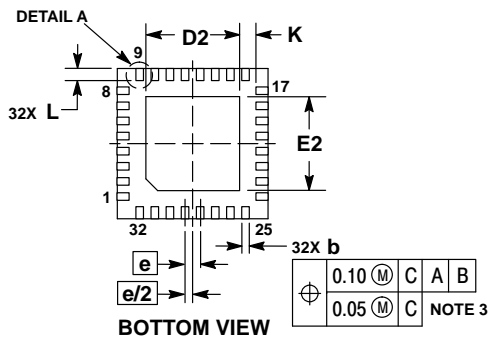
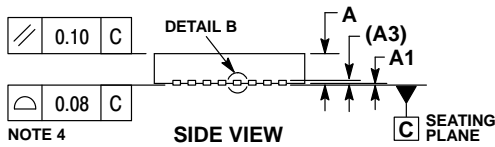
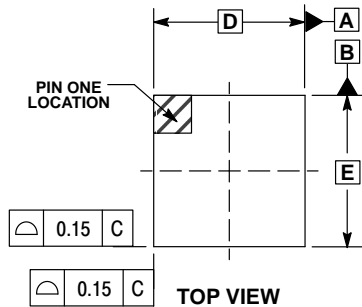

**NOTES:**

1. DIMENSIONS AND TOLERANCING PER ASME Y14.5M, 1994.
2. CONTROLLING DIMENSION: MILLIMETERS.
3. DIMENSION b APPLIES TO PLATED TERMINAL AND IS MEASURED BETWEEN 0.15 AND 0.30MM FROM THE TERMINAL TIP.
4. COPLANARITY APPLIES TO THE EXPOSED PAD AS WELL AS THE TERMINALS.

MILLIMETERS		
DIM	MIN	MAX
A	0.80	1.00
A1	---	0.05
A3	0.20	REF
b	0.18	0.30
D	5.00	BSC
D2	2.95	3.25
E	5.00	BSC
E2	2.95	3.25
e	0.50	BSC
K	0.20	---
L	0.30	0.50
L1	---	0.15

**RECOMMENDED  
SOLDERING FOOTPRINT\***

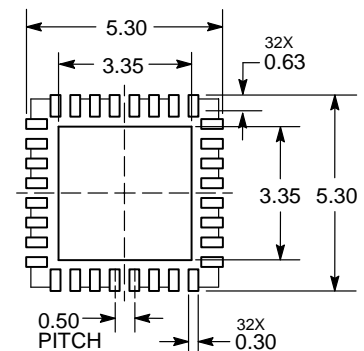

DIMENSION: MILLIMETERS

\*For additional information on our Pb-Free strategy and soldering details, please download the ON Semiconductor Soldering and Mounting Techniques Reference Manual, SOLDERRM/D.

BELASIGNA is a registered trademark of Semiconductor Components Industries, LLC.

ON Semiconductor and the are registered trademarks of Semiconductor Components Industries, LLC (SCILLC) or its subsidiaries in the United States and/or other countries. SCILLC owns the rights to a number of patents, trademarks, copyrights, trade secrets, and other intellectual property. A listing of SCILLC's product/patent coverage may be accessed at [www.onsemi.com/site/pdf/Patent-Marking.pdf](http://www.onsemi.com/site/pdf/Patent-Marking.pdf). SCILLC reserves the right to make changes without further notice to any products herein. SCILLC makes no warranty, representation or guarantee regarding the suitability of its products for any particular purpose, nor does SCILLC assume any liability arising out of the application or use of any product or circuit, and specifically disclaims any and all liability, including without limitation special, consequential or incidental damages. "Typical" parameters which may be provided in SCILLC data sheets and/or specifications can and do vary in different applications and actual performance may vary over time. All operating parameters, including "Typicals" must be validated for each customer application by customer's technical experts. SCILLC does not convey any license under its patent rights nor the rights of others. SCILLC products are not designed, intended, or authorized for use as components in systems intended for surgical implant into the body, or other applications intended to support or sustain life, or for any other application in which the failure of the SCILLC product could create a situation where personal injury or death may occur. Should Buyer purchase or use SCILLC products for any such unintended or unauthorized application, Buyer shall indemnify and hold SCILLC and its officers, employees, subsidiaries, affiliates, and distributors harmless against all claims, costs, damages, and expenses, and reasonable attorney fees arising out of, directly or indirectly, any claim of personal injury or death associated with such unintended or unauthorized use, even if such claim alleges that SCILLC was negligent regarding the design or manufacture of the part. SCILLC is an Equal Opportunity/Affirmative Action Employer. This literature is subject to all applicable copyright laws and is not for resale in any manner.

**PUBLICATION ORDERING INFORMATION**

**LITERATURE FULFILLMENT:**  
Literature Distribution Center for ON Semiconductor  
19521 E. 32nd Pkwy, Aurora, Colorado 80011 USA  
**Phone:** 303-675-2175 or 800-344-3860 Toll Free USA/Canada  
**Fax:** 303-675-2176 or 800-344-3867 Toll Free USA/Canada  
**Email:** [orderlit@onsemi.com](mailto:orderlit@onsemi.com)

**N. American Technical Support:** 800-282-9855 Toll Free  
USA/Canada  
**Europe, Middle East and Africa Technical Support:**  
Phone: 421 33 790 2910  
**Japan Customer Focus Center**  
Phone: 81-3-5817-1050

**ON Semiconductor Website:** [www.onsemi.com](http://www.onsemi.com)  
**Order Literature:** <http://www.onsemi.com/orderlit>

For additional information, please contact your local Sales Representative