

isc Silicon NPN Power Transistor

2SC4129

DESCRIPTION

- Collector-Emitter Breakdown Voltage-
: $V_{(BR)CEO} = 400V(\text{Min})$
- High Switching Speed
- Wide Area of Safe Operation

APPLICATIONS

- Designed for switching regulator and general purpose applications.

ABSOLUTE MAXIMUM RATINGS($T_a=25^\circ\text{C}$)

SYMBOL	PARAMETER	VALUE	UNIT
V_{CBO}	Collector-Base Voltage	400	V
V_{CEO}	Collector-Emitter Voltage	400	V
V_{EBO}	Emitter-Base Voltage	7	V
I_C	Collector Current-Continuous	5	A
I_{CM}	Collector Current-Peak	7	A
P_C	Collector Power Dissipation @ $T_a=25^\circ\text{C}$	1.5	W
	Collector Power Dissipation @ $T_C=25^\circ\text{C}$	30	
T_J	Junction Temperature	150	$^\circ\text{C}$
T_{stg}	Storage Temperature	-55~150	$^\circ\text{C}$

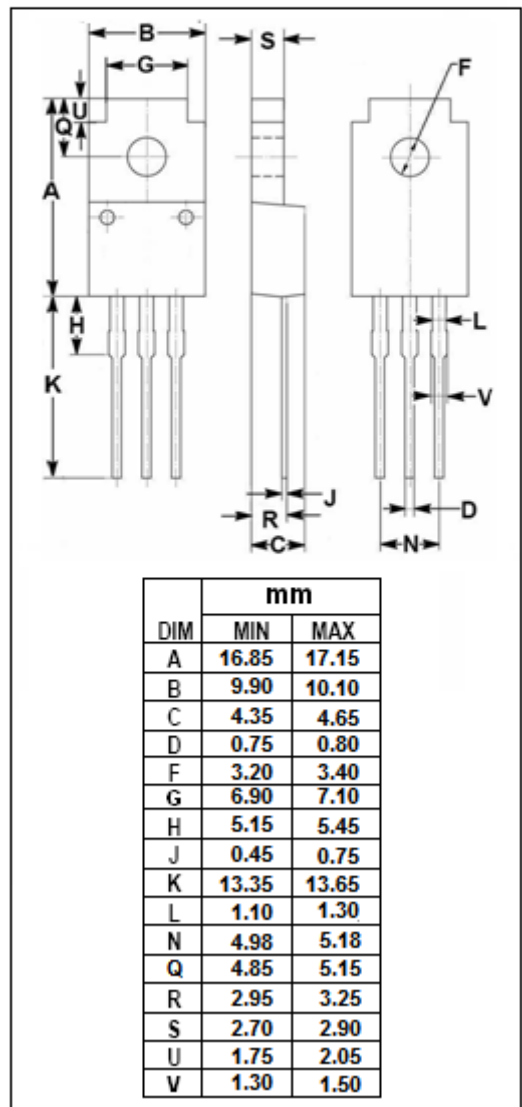
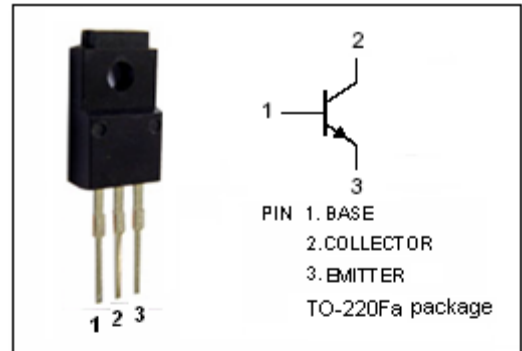

isc Silicon NPN Power Transistor**2SC4129****ELECTRICAL CHARACTERISTICS**T_j=25°C unless otherwise specified

SYMBOL	PARAMETER	CONDITIONS	MIN	TYP.	MAX	UNIT
V _{(BR)CEO}	Collector-Emitter Breakdown Voltage	I _C = 1mA; I _B = 0	400			V
V _{(BR)CBO}	Collector-Base Breakdown Voltage	I _C = 50 μ A; I _E = 0	400			V
V _{(BR)EBO}	Emitter-Base Breakdown Voltage	I _E = 50 μ A; I _C = 0	7			V
V _{CE(sat)}	Collector-Emitter Saturation Voltage	I _C = 5A; I _B = 1A			1.0	V
V _{BE(sat)}	Base-Emitter Saturation Voltage	I _C = 5A; I _B = 1A			1.5	V
I _{CBO}	Collector Cutoff Current	V _{CB} = 400V; I _E = 0			10	μ A
I _{EBO}	Emitter Cutoff Current	V _{EB} = 5V; I _C = 0			10	μ A
h _{FE}	DC Current Gain	I _C = 3A; V _{CE} = 5V	16		50	
C _{OB}	Output Capacitance	I _E = 0; V _{CB} = 10V; f= 1MHz		80		pF
f _T	Current-Gain—Bandwidth Product	I _E = -0.5A; V _{CE} = 10V		15		MHz