

Minimum lever wobble and high precision characteristics combined with good operational feel

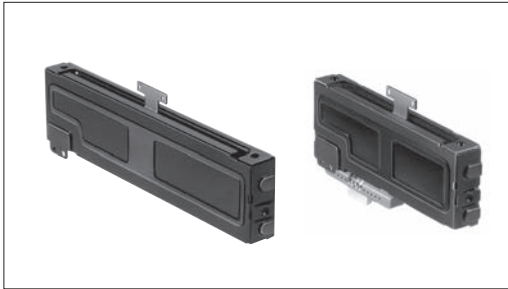

■ Typical Specifications



Items	Specifications
Total resistance tolerance	±20%
Maximum operating voltage	350V AC, 20V DC
Operating force	Please see P.408
Operating life	Please see P.408
Operating temperature range	-10°C to +60°C

■ Product Line

Type	Number of resistor elements	Travel (mm)	Lever type	Length of lever (mm)	Total resistance (kΩ)	Resistance taper	Minimum order unit (pcs.)		Products No.	Drawing No.
							Japan	Export		
Standard Type	Single-unit	60	9-T (T-Bar)	8.2	10	15A	50	100	RS60K11A9010	1
		100							RSA0K11A901L	2
	Dual-unit		1	12					RSA0K12A1013	3
CP Type	Single-unit	60	9-T (T-Bar)	8.2					RS60K11K9A13	4
		100							RSA0K11K9A16	5
	Dual-unit								RSA0K12K9A14	6

Note

Other varieties are also available. Refer to "Other Specifications" (P.408).

■ Packing Specifications

Bulk

Travel (mm)	Number of packages (pcs.)		Export package measurements (mm)
	1 case /Japan	1 case /export packing	
60	50	100	292×520×190
100	50	100	370×520×201

Refer to P.408 for other specifications.
 Refer to P.408 for details of lever types.
 Refer to P.409 for ordering products not listed.
 Refer to P.426 for soldering conditions.

Dimensions

Unit:mm

No.	Style	
1		
2		
3		

Rotary Potentiometers
 Slide Potentiometers
 General-Use
 Mixer

Dimensions

Unit:mm

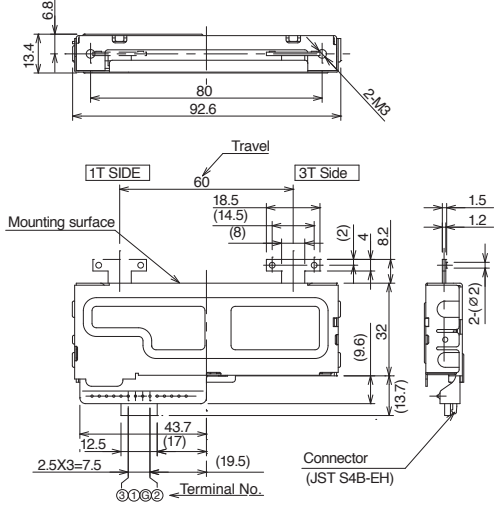
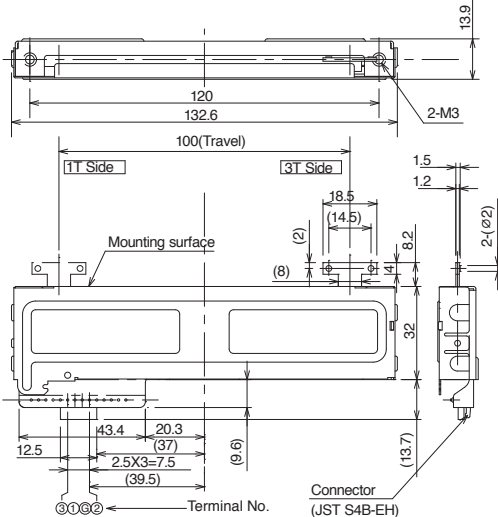
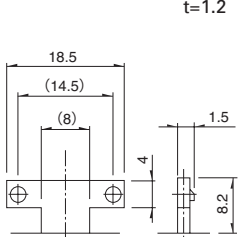
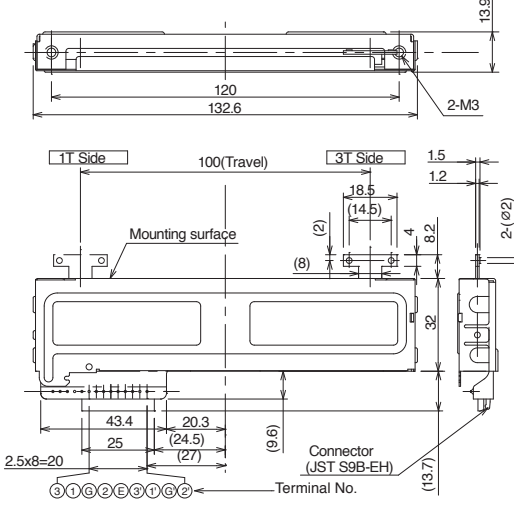
No.	Style	
4		
5		
6		

Rotary Potentiometers

Slide Potentiometers

General-use

Mixer

Master Type (K Fader) / Other Specifications

In addition to the products listed, we can accommodate the follow specifications.

Specifications

Type		Travel (mm)	Terminal style		Operating force	Sliding life	Micro switch
Standard type	Single-unit	60 / 100	Lead type		$0.3^{+0.3N}_{-0.2}$	100,000 cycles	Available (100mm only)
	Dual-unit				$0.4 \pm 0.3N$		
CP type	Single-unit		Connector type	JST S4B-EH	$0.2 \pm 0.15N$	300,000 cycles	
	Dual-unit			JST S9B-EH	$0.3 \pm 0.2N$		

Lever Types

Configuration code	1	4	9-T (T-Bar)
Dimensions			

Total Resistance Variety

Total resistance (k Ω)	10*	50	100
------------------------	-----	----	-----

*CP type: Only 10 kΩ

Resistance Taper

Resistance taper	15A	1B
------------------	-----	----

Circuit Diagram

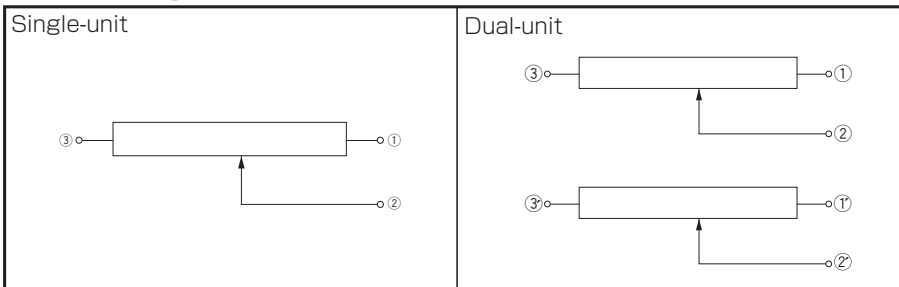

Note

Marked are specifications recommended by Alps.

When ordering product varieties that are not listed, specify referring to the examples below.

Sample Part Number

R S 6 0 K 1 1 A - 9 T - A 1 0 3

Travel

60	60mm
A0	100mm

Number of resistor elements

Single-unit	1
Dual-unit	2

Resistor element type, and presence of micro switch.

Code	Resistor elements Standard type	Code	Resistor elements CP type
A	Without micro switch	K	Without micro switch
B	With micro switch	L	With micro switch

Lever types

Code	Configuration code
01	1
04	4
9T	9-T (T-Bar)

Resistance taper

Code	Resistance taper
A	15A
B	1B

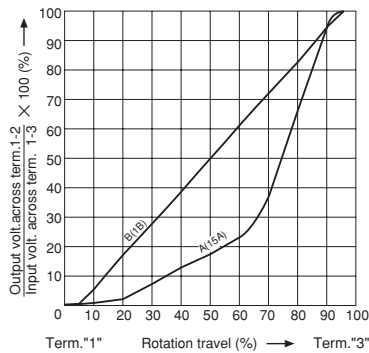

Total resistance

Code	Total resistance (k Ω)	Code	Total resistance (k Ω)
103	10	104	100
503	50	254	250

CP type: Supports 10kΩ only.









Note

Marked are specifications recommended by Alps.

Rotary
Potentiometers
Slide
Potentiometers
General-use
Mixer

Slide Potentiometers

List of Varieties

Type		Standard Type			Master Type	
Series	Super Slide™	Slim Slide™ (Slim4)		Compact Reflow Type	K Fader	
	RS □□ 1	RS □□ H		RS08U	RS □□ K	
	Single-unit/Dual-unit	Single-unit/Dual-unit		Single-unit	Single-unit/Dual-unit	
Photo						
Travel (mm)		15, 20, 30, 45, 60	15, 20, 30		8	60, 100
Direction of lever		Vertical		Horizontal	Vertical Horizontal	Vertical
Lever material		Metal / Resin	Resin			Metal
Operating temperature range		-25°C to +70°C			-10°C to +70°C	-10°C to +60°C
Operating life		15,000 cycles	10,000 cycles			100,000 cycles (Standard) 300,000 cycles (CP)
Available for automotive use		○	—	—	—	—
Life cycle (availability)						
Electrical performance	Total resistance (k Ω)	10, 20, 50, 100, 200	5, 10, 20, 50, 100, 200, 250		10	10, 50, 100(Standard) 10 (CP)
	Resistance taper	10A, 15A, 1B, 3B, 4B	15A, 1B, 3B		1B	15A, 1B
	Rated Power	Please see P.395	Please see P.402		0.025W	0.25W
	Insulation resistance	100MΩ min. 250V DC	Dual-unit: 100MΩ min. 250V DC		100MΩ min. 100V DC	100MΩ min. 250V DC
	Voltage proof	300V AC for 1 minute	Dual-unit: 300V AC for 1 minute		100V AC for 1 minute	250V AC for 1 minute
	Center-taps	Without / With			Without	
Mechanical performance	Operating force	0.3 to 2.5N	0.6 ^{+0.5} _{-0.4} N		0.17±0.15N	Please see P.408
	Center detent	Without / With			Without	
	Stopper strength	50N	30N		5N	100N
	Lever push-pull strength	50N	30N		5N	100N
	Lever wobble (mm) ※ Both sides	$\frac{2(2 \times L)}{20}$	1.6 max.		—	$\frac{2(2 \times L)}{25}$
	Detent slip-out force	Operating force + (0.2 to 2N)	Operating force +0.3 ^{+0.5} _{-0.25} N		—	—
	Lever deviation (mm) ※ One side	0.5 max.	—	—	—	0.5 max.
Terminal style		Insertion			Reflow	Lead (Standard) Connector (CP)
Page		389	398		404	405

Slide Potentiometers Soldering Conditions	426
Potentiometer Cautions	427
Potentiometers Measurement and Test Methods	429
Potentiometers Resistance Taper	431

Notes

- "L" in the "Lever Wobble" column of the above table indicates the length of lever.
- RS □□
 □□ indicates travel.
- Indicates applicability to some products in the series.

Reference for Manual Soldering

Series	Tip temperature	Duration of Soldering time	No. of solders
RS□□1, RS□□H, RS08U, RS□□K (Standard), RS□□N, RS□□N11S, RS6011□P, RS□□N1□M, RSA0K1□V (Motor terminal)	350°C max.	3s max.	1 time

Reference for Dip Soldering

Series	Preheating		Dip soldering		Number of soldering
	Soldering surface temperature	Heating time	Soldering temperature	Soldering time	
RS□□1, RS□□H, RS□□N, RS□□N11S, RS6011□P, RS□□N1□M	100°C max.	1 min. max.	260°C	5s max.	1 time

Example of Reflow Soldering Condition

Temperature profile

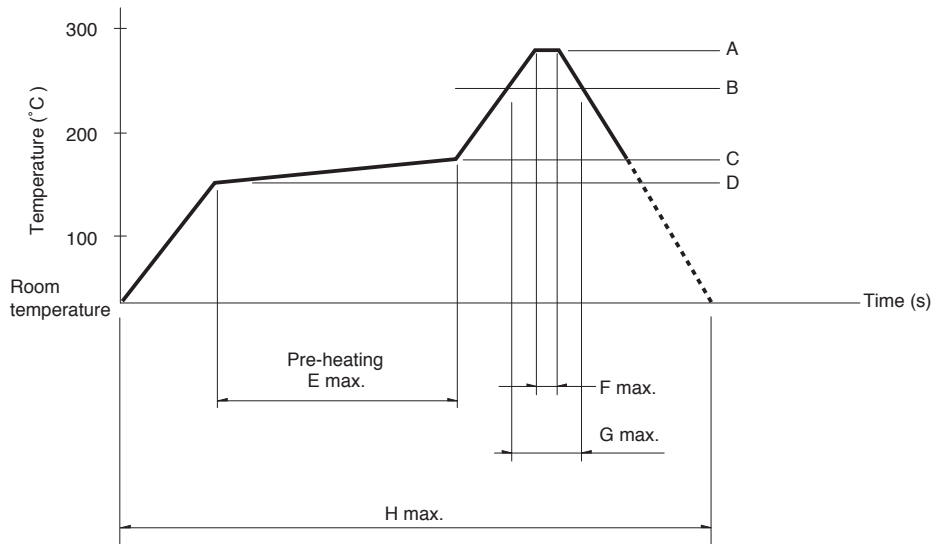

Series	A	B	C	D	E	F	G	H	No. of reflows
RS08U	250°C	200°C	150°C	150°C	2 min.	3s	40s	4 min.	1 time

Notes

1. When using an infrared reflow oven, solder may sometimes not be applied. Be sure to use a hot air reflow oven or a type that uses infrared rays in combination with hot air.
2. The temperatures given above are the maximum temperatures at the terminals of the potentiometer when employing a hot air reflow method. The temperature of the PC board and the surface temperature of the potentiometer may vary greatly depending on the PC board material, its size and thickness. Ensure that the surface temperature of the potentiometer does not rise to 250°C or greater.
3. Conditions vary to some extent depending on the type of reflow bath used. Be sure to give due consideration to this prior to use.