

Dual, Low Noise, High Performance Operational Amplifier

July 1994

Features

- This Circuit is Processed in Accordance to MIL-STD-883 and is Fully Conformant Under the Provisions of Paragraph 1.2.1.
- Low Input Noise Voltage Density at 1kHz. . . $6\text{nV}/\sqrt{\text{Hz}}$ (Max)
 $4.3\text{nV}/\sqrt{\text{Hz}}$ (Typ)
- High Slew Rate. $1\text{V}/\mu\text{s}$ (Min)
 $3\text{V}/\mu\text{s}$ (Typ)
- Unity Gain Bandwidth 8MHz (Typ)
- High Open Loop Gain (Full Temp) $100\text{kV}/\text{V}$ (Min)
 $250\text{kV}/\text{V}$ (Typ)
- High CMRR, PSRR (Full Temp) 86dB (Min)
 100dB (Typ)
- Low Offset Voltage Drift $3\mu\text{V}/^\circ\text{C}$ (Typ)
- No Crossover Distortion
- Standard Dual Pinout

Applications

- High Quality Audio Preamplifiers
- High Q Active Filters
- Low Noise Function Generators
- Low Distortion Oscillators
- Low Noise Comparators

Description

Low noise and high performance are key words describing the unity gain stable HA-5102/883. This general purpose dual amplifier offers an array of dynamic specifications including $1\text{V}/\mu\text{s}$ slew rate (min), $A_{VCL} \geq 1$, and 8MHz bandwidth (typ). Complementing these outstanding parameters is a very low noise specification of $4.3\text{nV}/\sqrt{\text{Hz}}$ at 1kHz (typ), $6\text{nV}/\sqrt{\text{Hz}}$ (max).

Fabricated using the Intersil standard high frequency D.I. process, these operational amplifiers also offer excellent input specifications such as 2.5mV (max) offset voltage and 75nA (max) offset current. Complementing these specifications are 100dB (min) open loop gain and 60dB channel separation (min). Economically, the HA-5102/883 also consumes a very moderate amount of supply power 180mW /package.

This impressive combination of features make this amplifier ideally suited for designs ranging from audio amplifiers and active filters to the most demanding signal conditioning and instrumentation circuits.

Ordering Information

PART NUMBER	TEMPERATURE RANGE	PACKAGE
HA2-5102/883	-55°C to $+125^\circ\text{C}$	8 Pin Can
HA4-5102/883	-55°C to $+125^\circ\text{C}$	20 Lead Ceramic LCC
HA7-5102/883	-55°C to $+125^\circ\text{C}$	8 Lead CerDIP

Pinouts

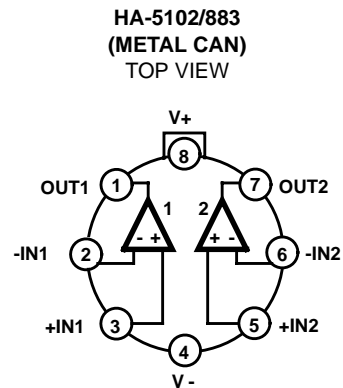
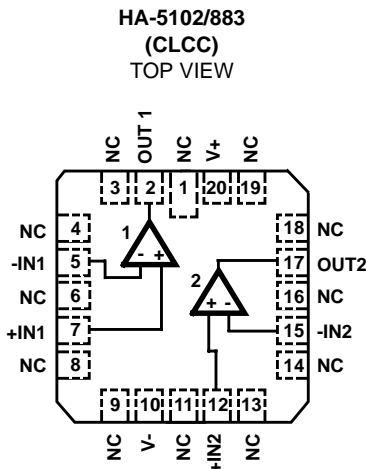
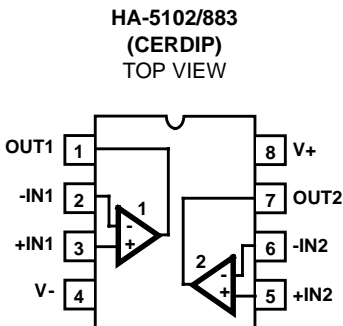

Specifications HA-5102/883

Absolute Maximum Ratings

Voltage Between V+ and V- Terminals	40V
Differential Input Voltage	7V
Voltage at Either Input Terminal	V+ to V-
Peak Output Current	Indefinite (One Amplifier Shorted to Ground)
Junction Temperature (T _J)	+175°C
Storage Temperature Range	-65°C to +150°C
ESD Rating	<2000V
Lead Temperature (Soldering 10s)	+300°C

Thermal Information

Thermal Resistance	θ_{JA}	θ_{JC}
CerDIP Package	115°C/W	28°C/W
Ceramic LCC Package	65°C/W	15°C/W
Metal Can Package	155°C/W	67°C/W
Package Power Dissipation Limit at +75°C for T _J ≤ +175°C		
CerDIP Package	870mW	
Ceramic LCC Package	1.54W	
Metal Can Package	645mW	
Package Power Dissipation Derating Factor Above +75°C		
CerDIP Package	8.7mW/°C	
Ceramic LCC Package	15.4mW/°C	
Metal Can Package	6.5mW/°C	

CAUTION: Stresses above those listed in "Absolute Maximum Ratings" may cause permanent damage to the device. This is a stress only rating and operation of the device at these or any other conditions above those indicated in the operational sections of this specification is not implied.

Operating Conditions

Operating Temperature Range	-55°C to +125°C	$V_{INCM} \leq 1/2 (V+ - V-)$
Operating Supply Voltage	±5V to ±15V	$R_L \geq 2k\Omega$

TABLE 1. DC ELECTRICAL PERFORMANCE CHARACTERISTICS

Device Tested at: V_{SUPPLY} = ±15V, R_{SOURCE} = 100Ω, R_{LOAD} = 500kΩ, V_{OUT} = 0V, Unless Otherwise Specified.

PARAMETERS	SYMBOL	CONDITIONS	GROUP A SUBGROUPS	TEMPERATURE	LIMITS		UNITS
					MIN	MAX	
Input Offset Voltage	V _{IO}	V _{CM} = 0V	1	+25°C	-2.0	2.0	mV
			2, 3	+125°C, -55°C	-2.5	2.5	mV
Input Bias Current	+I _B	V _{CM} = 0V, +R _S = 10kΩ, -R _S = 100kΩ	1	+25°C	-200	200	nA
			2, 3	+125°C, -55°C	-325	325	nA
	-I _B	V _{CM} = 0V, +R _S = 100kΩ, -R _S = 10kΩ	1	+25°C	-200	200	nA
			2, 3	+125°C, -55°C	-325	325	nA
Input Offset Current	I _{IO}	V _{CM} = 0V, +R _S = 10kΩ, -R _S = 10kΩ	1	+25°C	-75	75	nA
			2, 3	+125°C, -55°C	-125	125	nA
Common Mode Range	+CMR	V+ = +3V, V- = -27V	1	+25°C	+12	-	V
			2, 3	+125°C, -55°C	+12	-	V
	-CMR	V+ = +27V, V- = -3V	1	+25°C	-	-12	V
			2, 3	+125°C, -55°C	-	-12	V
Large Signal Voltage Gain	+A _{VOL}	V _{OUT} = 0V and +10V, R _L = 2kΩ	4	+25°C	100	-	kV/V
			5, 6	+125°C, -55°C	100	-	kV/V
	-A _{VOL}	V _{OUT} = 0V and -10V, R _L = 2kΩ	4	+25°C	100	-	kV/V
			5, 6	+125°C, -55°C	100	-	kV/V
Common Mode Rejection Ratio	+CMRR	ΔV _{CM} = +5V, V+ = +10V, V- = -20V, V _{OUT} = -5V	1	+25°C	86	-	dB
			2, 3	+125°C, -55°C	86	-	dB
	-CMRR	ΔV _{CM} = -5V, V+ = +20V, V- = -10V, V _{OUT} = +5V	1	+25°C	86	-	dB
			2, 3	+125°C, -55°C	86	-	dB

Specifications HA-5102/883

TABLE 1. DC ELECTRICAL PERFORMANCE CHARACTERISTICS (Continued)

Device Tested at: $V_{SUPPLY} = \pm 15V$, $R_{SOURCE} = 100\Omega$, $R_{LOAD} = 500k\Omega$, $V_{OUT} = 0V$, Unless Otherwise Specified.

PARAMETERS	SYMBOL	CONDITIONS	GROUP A SUBGROUPS	TEMPERATURE	LIMITS		UNITS	
					MIN	MAX		
Output Voltage Swing	+V _{OUT1}	R _L = 2kΩ	1	+25°C	10	-	V	
			2, 3	+125°C, -55°C	10	-	V	
	-V _{OUT1}	R _L = 2kΩ	1	+25°C	-	-10	V	
			2, 3	+125°C, -55°C	-	-10	V	
	+V _{OUT2}	R _L = 10kΩ	1	+25°C	12	-	V	
			2, 3	+125°C, -55°C	12	-	V	
	-V _{OUT2}	R _L = 10kΩ	1	+25°C	-	-12	V	
			2, 3	+125°C, -55°C	-	-12	V	
	Output Current	+I _{OUT}	V _{OUT} = -5V	1	+25°C	10	-	mA
				2, 3	+125°C, -55°C	10	-	mA
-I _{OUT}		V _{OUT} = +5V	1	+25°C	-	-10	mA	
			2, 3	+125°C, -55°C	-	-10	mA	
Quiescent Power Supply Current	+I _{CC}	V _{OUT} = 0V, I _{OUT} = 0mA	1	+25°C	-	5.0	mA	
			2, 3	+125°C, -55°C	-	6.0	mA	
	-I _{CC}	V _{OUT} = 0V, I _{OUT} = 0mA	1	+25°C	-5.0	-	mA	
			2, 3	+125°C, -55°C	-6.0	-	mA	
Power Supply Rejection Ratio	+PSRR	ΔV _{SUP} = 10V, V+ = +10V, V- = -15V V+ = +20V, V- = -15V	1	+25°C	86	-	dB	
			2, 3	+125°C, -55°C	86	-	dB	
	-PSRR	ΔV _{SUP} = 10V, V+ = +15V, V- = -10V V+ = +15V, V- = -20V	1	+25°C	86	-	dB	
			2, 3	+125°C, -55°C	86	-	dB	

TABLE 2. AC ELECTRICAL PERFORMANCE CHARACTERISTICS

Device Tested at: $V_{SUPPLY} = \pm 15V$, $R_{SOURCE} = 50\Omega$, $R_{LOAD} = 2k\Omega$, $C_{LOAD} = 50pF$, $A_{VCL} = +1V/V$, Unless Otherwise Specified.

PARAMETERS	SYMBOL	CONDITIONS	GROUP A SUBGROUPS	TEMPERATURE	LIMITS		UNITS
					MIN	MAX	
Slew Rate	+SR	V _{OUT} = -3V to +3V	4	+25°C	1	-	V/μs
	-SR	V _{OUT} = +3V to -3V	4	+25°C	1	-	V/μs
Rise and Fall Time	T _R	V _{OUT} = 0 to +200mV 10% ≤ T _R ≤ 90%	4	+25°C	-	200	ns
	T _F	V _{OUT} = 0 to -200mV 10% ≤ T _F ≤ 90%	4	+25°C	-	200	ns
Overshoot	+OS	V _{OUT} = 0 to +200mV	4	+25°C	-	35	%
	-OS	V _{OUT} = 0 to -200mV	4	+25°C	-	35	%

Specifications HA-5102/883

TABLE 3. ELECTRICAL PERFORMANCE CHARACTERISTICS

Device Characterized at: $V_{SUPPLY} = \pm 15V$, $R_{LOAD} = 2k\Omega$, $C_{LOAD} = 50pF$, $A_{VCL} = 1V/V$, Unless Otherwise Specified.

PARAMETERS	SYMBOL	CONDITIONS	NOTES	TEMPERATURE	LIMITS		UNITS
					MIN	MAX	
Differential Input Resistance	R_{IN}	$V_{CM} = 0V$	1	+25°C	250	-	k Ω
Input Noise Voltage Density	E_N	$R_S = 20\Omega$, $f_O = 1000Hz$	1	+25°C	-	6	nV/ \sqrt{Hz}
Input Noise Current Density	I_N	$R_S = 2M\Omega$, $f_O = 1000Hz$	1	+25°C	-	3	pA/ \sqrt{Hz}
Full Power Bandwidth	FPBW	$V_{PEAK} = 10V$	1, 2	+25°C	16	-	kHz
Minimum Closed Loop Stable Gain	CLSG	$R_L = 2k\Omega$, $C_L = 50pF$	1	-55°C to +125°C	+1	-	V/V
Output Resistance	R_{OUT}	Open Loop	1	+25°C	-	360	Ω
Quiescent Power Consumption	PC	$V_{OUT} = 0V$, $I_{OUT} = 0mA$	1, 3	-55°C to +125°C	-	180	mW
Channel Separation	CS	$R_S = 1k\Omega$, $A_{VCL} = 100V/V$, $V_{IN} = 100mV_{PEAK}$ at 10kHz Referred to Input	1	+25°C	60	-	dB

NOTES:

- Parameters listed in Table 3 are controlled via design or process parameters and are not directly tested at final production. These parameters are lab characterized upon initial design release, or upon design changes. These parameters are guaranteed by characterization based upon data from multiple production runs which reflect lot to lot and within lot variation.
- Full Power Bandwidth guarantee based on Slew Rate measurement using $FPBW = Slew\ Rate / (2\pi V_{PEAK})$.
- Quiescent Power Consumption based upon Quiescent Supply Current test maximum. (No load on outputs.)

TABLE 4. ELECTRICAL TEST REQUIREMENTS

MIL-STD-883 TEST REQUIREMENTS	SUBGROUPS (SEE TABLES 1 AND 2)
Interim Electrical Parameters (Pre Burn-In)	1
Final Electrical Test Parameters	1 (Note 1), 2, 3, 4, 5, 6
Group A Test Requirements	1, 2, 3, 4, 5, 6
Groups C and D Endpoints	1

NOTE:

- PDA applies to Subgroup 1 only.

Die Characteristics

DIE DIMENSIONS:

98.4 x 67.3 x 19 mils ± 1 mils
 2500 x 1710 x 483µm ± 25.4µm

METALLIZATION:

Type: Al, 1% Cu
 Thickness: 16kÅ ± 2kÅ

GLASSIVATION:

Type: Nitride (Si3N4) over Silox (SiO2, 5% Phos.)
 Silox Thickness: 12kÅ ± 2kÅ
 Nitride Thickness: 3.5kÅ ± 1.5kÅ

WORST CASE CURRENT DENSITY:

1.43 x 10⁵ A/cm² at 10mA

SUBSTRATE POTENTIAL (Powered Up):

Unbiased

TRANSISTOR COUNT: 93

PROCESS: Bipolar Dielectric Isolation

Metallization Mask Layout

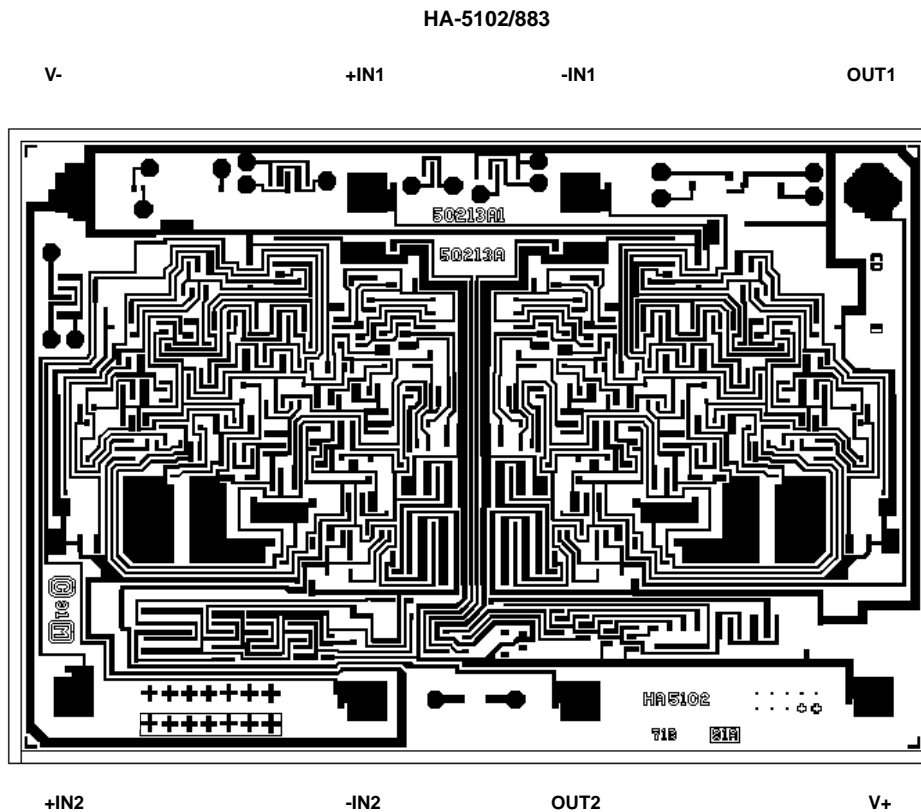

All Intersil semiconductor products are manufactured, assembled and tested under **ISO9000** quality systems certification.

Intersil products are sold by description only. Intersil Corporation reserves the right to make changes in circuit design and/or specifications at any time without notice. Accordingly, the reader is cautioned to verify that data sheets are current before placing orders. Information furnished by Intersil is believed to be accurate and reliable. However, no responsibility is assumed by Intersil or its subsidiaries for its use; nor for any infringements of patents or other rights of third parties which may result from its use. No license is granted by implication or otherwise under any patent or patent rights of Intersil or its subsidiaries.

For information regarding Intersil Corporation and its products, see web site <http://www.intersil.com>