

# ACPF-8040

## Bandpass Filter for 3GPP Band 40



### Data Sheet



#### Description

The Avago ACPF-8040 is a miniaturized Bandpass Filter designed for use in 3GPP Band 40 wireless applications (2300 – 2400 MHz DL, 2300 – 2380 MHz UL).

The ACPF-8040 is designed to enable concurrent operation of 3GPP Band 40 with applications in adjacent frequency spectrum, such as ISM 2.4 GHz band (WLAN, Bluetooth). The ACPF-8040 uses Avago Technologies' innovative Film Bulk Acoustic Resonator (FBAR) technology, which makes possible ultra-small, high-Q filters at a fraction of their usual size.

The ACPF-8040 is compatible with high volume, lead-free SMT soldering processes and can be direct surface mounted to a PCB or a transfer molded module.

#### Functional Block Diagram

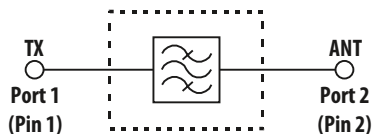

#### Features

- 50  $\Omega$  Input/Output
- No external matching required
- Low Insertion Loss, High Interference Rejection
- Miniature Size
  - 1.6 x 2.0 mm size
  - 0.95 mm Max Height
- High Power Rating
  - +30 dBm Abs Max Input Power
- Environmental
  - RoHS 6 Compliant
  - Halogen free
  - TBBPA Free

#### Specifications (Typ, 25° C)

- Insertion Loss:  $\leq 2.0$  dB
- Rejection
  - IEEE 802.11 b/g/n signals:  $\geq 35$  dB Typ
  - 3GPP Band 7 and Band 38:  $\geq 35$  dB Typ

#### Applications

3GPP Band 40 applications in handsets, mobile and portable communications devices. Optimum performance 2300 – 2380 MHz, usable 2300 – 2400 MHz.

## ACPF-8040 Electrical Specifications<sup>[2]</sup>, $Z_0 = 50 \Omega$ , $T_c$ <sup>[1]</sup>

Symbol	Parameter	Units	+25° C		+15° to +35° C		-30° to +85° C	
			Typ <sup>[3]</sup>	Min	Max	Min	Max	
S21 (S12)	Insertion Loss 3GPP Band 40 (20 MHz channel average <sup>[4]</sup> ) 2300 – 2380 MHz 2380 – 2400 MHz	dB	1.3		1.7		2.0	
			2.0		3.0		4.5	
S21 (S12)	Insertion Loss 3GPP Band 40, (Single tone) 2300 – 2380 MHz	dB	1.3		2.5		2.7	
S21 (S12)	20 MHz Channel Flatness (p-p) 2300 – 2380 MHz	dB	0.6		1.0			
S21 (S12)	Attenuation in Cell Rx Band 869 – 894 MHz	dB	32	30			30	
S21 (S12)	Attenuation in GPS Band 1574.4 – 1576.4 MHz	dB	33	30			30	
S21 (S12)	Attenuation in PCS Rx Band 1930.5 – 1989.5 MHz	dB	47	35			30	
S21 (S12)	Attenuation in WLAN/ISM 2.4GHz Band (Averaged per channel using 802.11b spectrum mask) 2401 – 2423 MHz (Channel 1) 2404 – 2428 MHz (Channel 2) 2411 – 2433 MHz (Channel 3) 2416 – 2495 MHz (Channels 4 to 14)	dB	39	17			11	
			46	35			22	
			60	50			48	
			62	52			50	
			45	37			35	
S21 (S12)	Attenuation in 3GPP Band 7, Band 38 2500 – 2690 MHz	dB	45	37			35	
S21 (S12)	Attenuation, 3400 – 3500 MHz	dB	11.4					
S21 (S12)	Attenuation in Band 40 2 <sup>nd</sup> Harmonic 4600 – 4800 MHz	dB	26	25			25	
S11	Return Loss (SWR) at Ant (Port 1) 2300 – 2380 MHz	dB	17 (1.3)	9 (2.1)			9 (2.1)	
S22	Return Loss (SWR) at Tx/Rx (Port 2) 2300 – 2380 MHz	dB	18 (1.3)	9 (2.1)			9 (2.1)	

### Notes:

- $T_c$  is the case temperature and is defined as the temperature of the underside of the Filter where it makes contact with the circuit board.
- Min/Max specifications are guaranteed at the indicated temperature (unless otherwise noted).
- Typical data is the average value (arithmetic mean) of the parameter over the indicated band at the specified temperature. Typical values may vary over time.
- Channel average Insertion Loss is obtained by averaging  $|S_{21}|$  over 20 MHz channels and converting to dB values.

## ACPF-8040

### Absolute Maximum Ratings<sup>[1]</sup>

Parameter	Unit	Value
Storage temperature	°C	-40 to +125
Maximum RF Input Power, 2300 – 2380 MHz	dBm	+30

### Maximum Recommended Operating Conditions<sup>[2]</sup>

Parameter	Unit	Value
Operating temperature, $T_c$ <sup>[3]</sup>	°C	-30 to +85

### Notes:

- Operation in excess of any one of these conditions may result in permanent damage to the device.
- The device will function over the recommended range without degradation in reliability or permanent change in performance, but is not guaranteed to meet electrical specifications.
- $T_c$  is defined as case temperature, the temperature of the underside of the Filter where it makes contact with the circuit board.

**ACPF-8040 Typical Performance at  $T_c = 25^\circ C$**

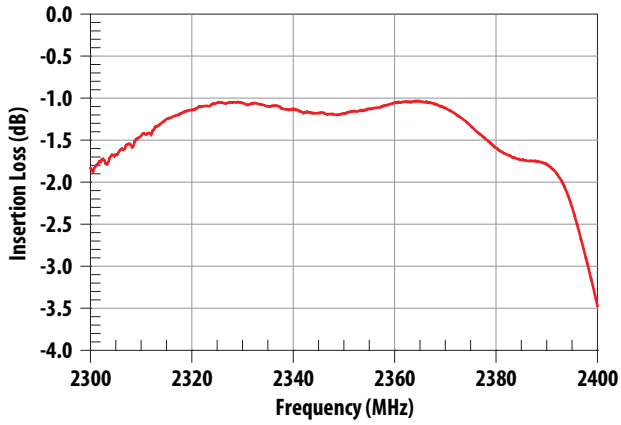

Figure 1. Insertion Loss, 3GPP Band 40

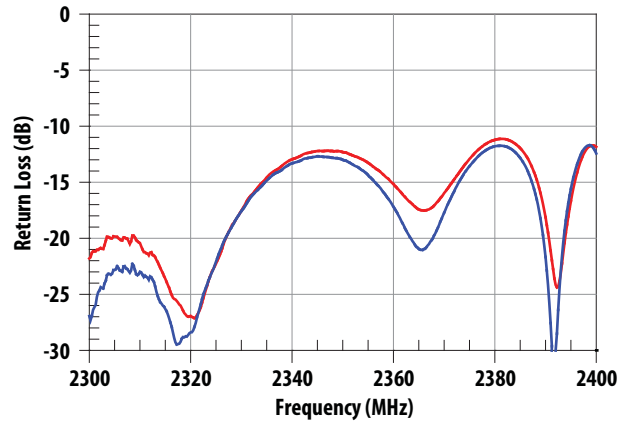

Figure 2. Return Loss, 3GPP Band 40

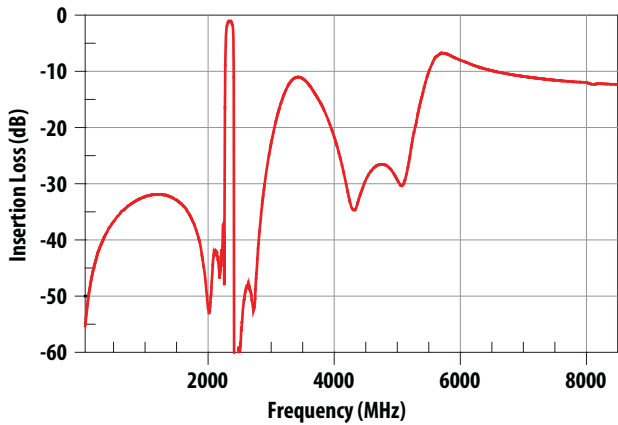

Figure 3. Wideband Attenuation, 50 – 8500 MHz

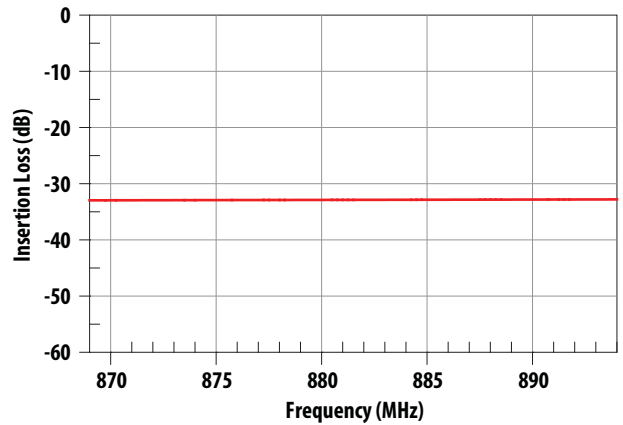

Figure 4. Attenuation, Cellular Rx Band

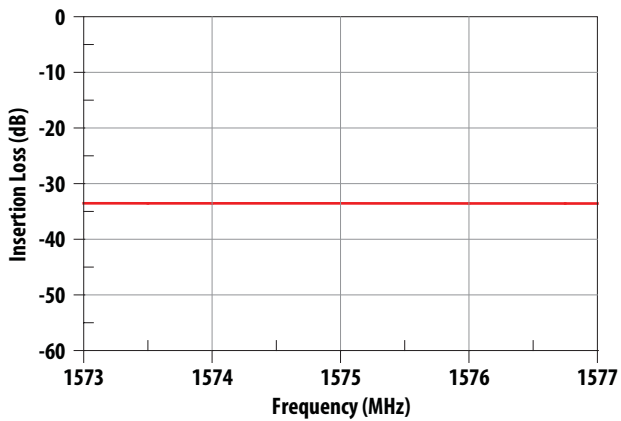

Figure 5. Attenuation, GPS Band

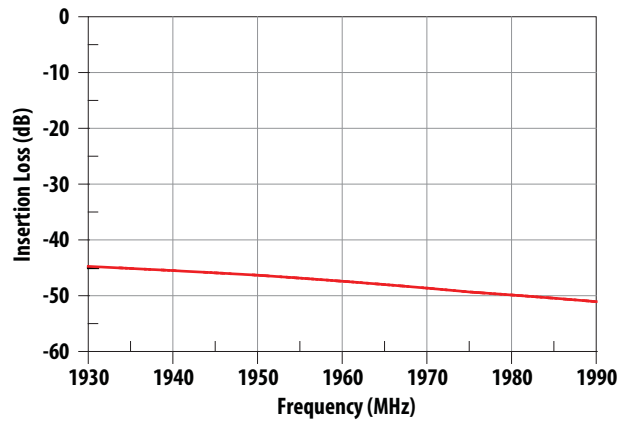

Figure 6. Attenuation, PCS Rx Band

**ACPF-8040 Typical Performance at  $T_c = 25^\circ\text{C}$**

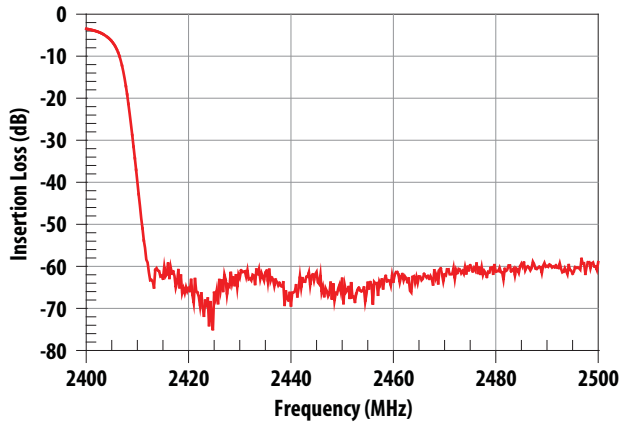

Figure 7. Attenuation, WLAN/2.5 GHz ISM Band

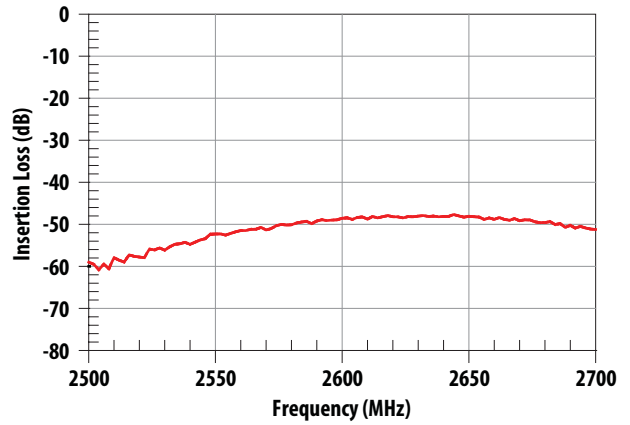

Figure 8. Attenuation, Band 7, Band 38

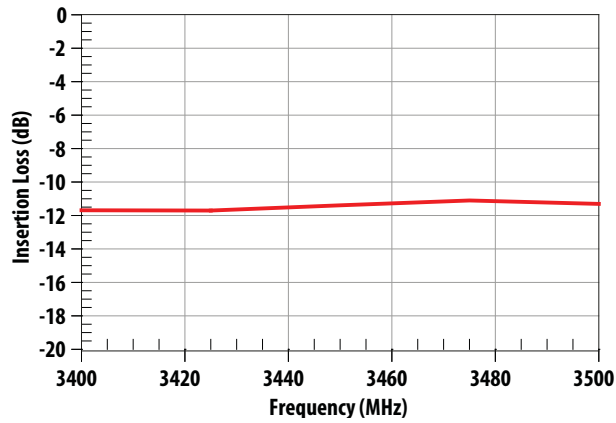

Figure 9. Attenuation, 3.4 – 3.5 GHz

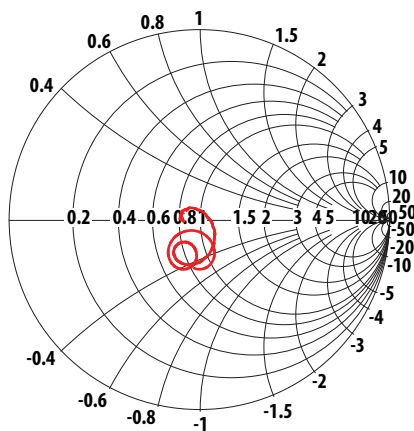

Figure 10. S11, 3GPP Band 40

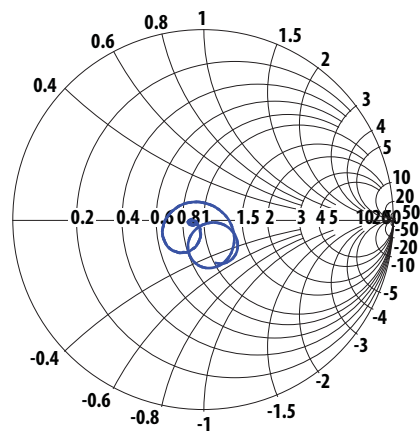
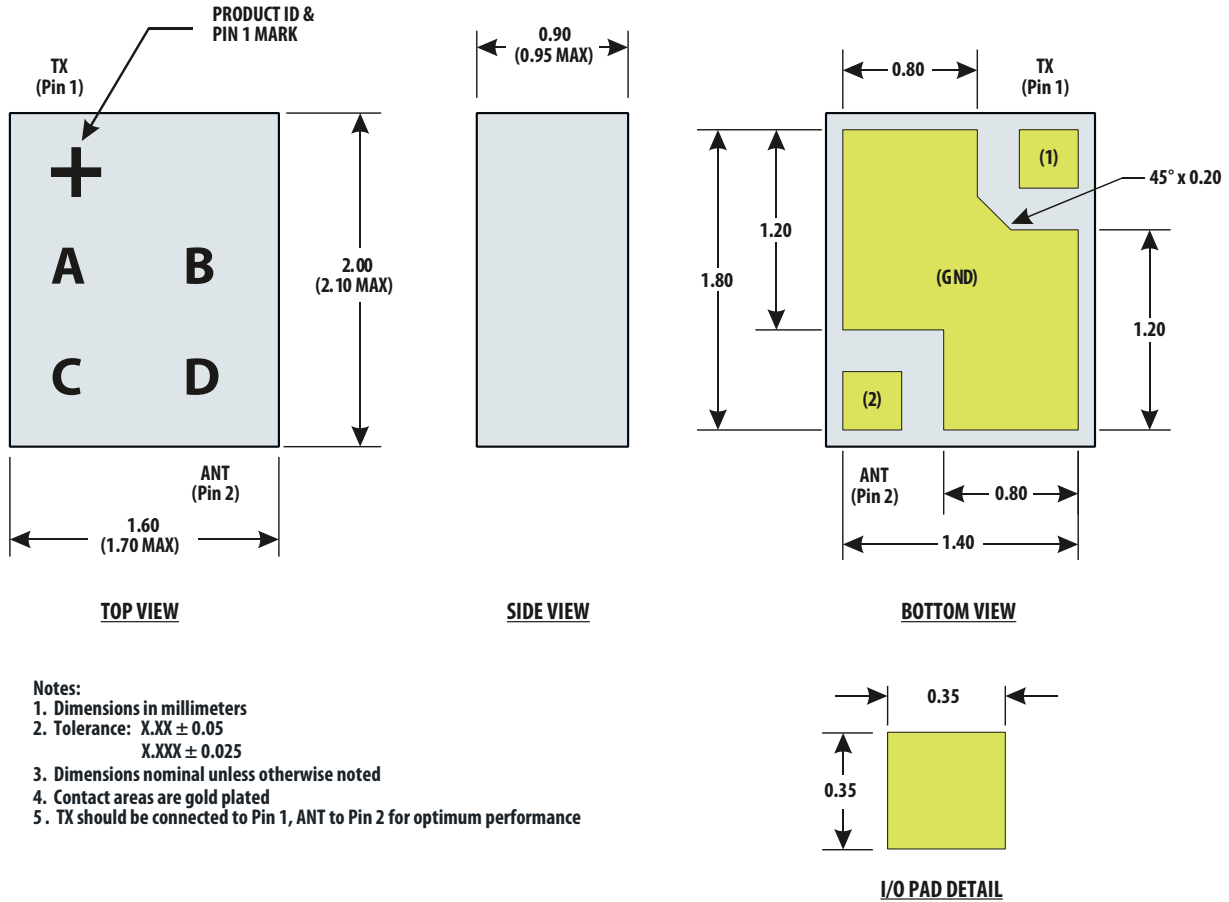
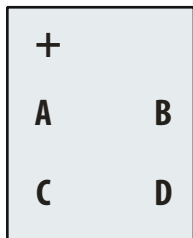

Figure 11. S22, 3GPP Band 40

**ACPF-8040**



**Figure 12. Package Outline Drawing and Marking**



- + = Product Identification (ACPF-8040 and Package Orientation Mark (Pin 1))
- A = Work Week
- B = Date Code
- C, D = Manufacturing Lot Number

**Figure 13. Package Marking**

## ACPF-8040

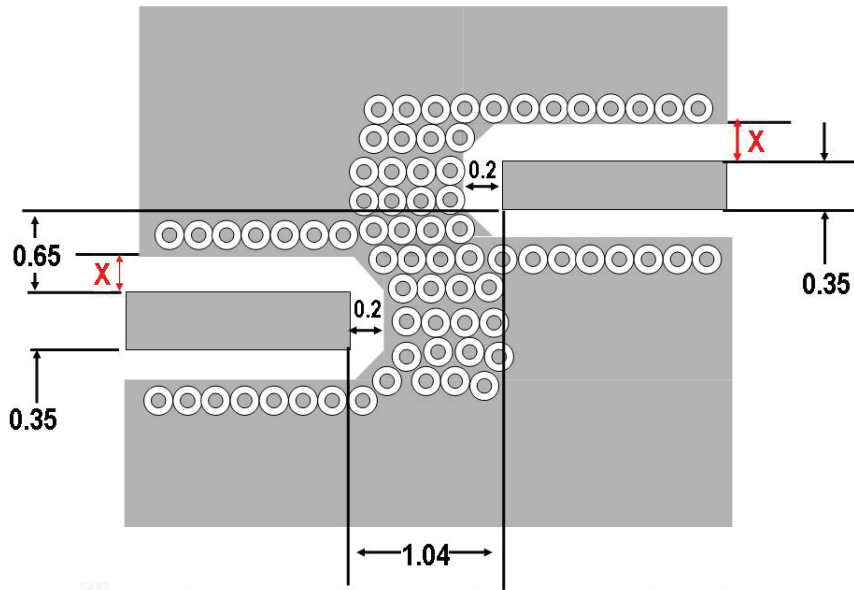

**X** should be the correct value to have 50-ohm Coplanar Waveguide line depending on PCB & dielectric thickness. Units in mm

Notes:

1. Dimensions in mm
2. Top view

**Figure 14. Suggested PCB Layout (top view)**

A PCB layout using the principles illustrated in the figure above is recommended to optimize performance of the ACPF-8040.

Note: This filter is not completely symmetrical. Optimum performance is obtained with the Tx block connected to Pin 1 and the system Antenna connected to Pin 2.

It is important to maximize isolation between the Input and Output ports to maintain out-of-band rejection.

High isolation is achieved by: (1) maintaining a continuous ground plane around the I/O connections, and (2) surrounding the I/O ports with sufficient ground vias to enclose the connections in a "Faraday cage."

# ACPF-8040

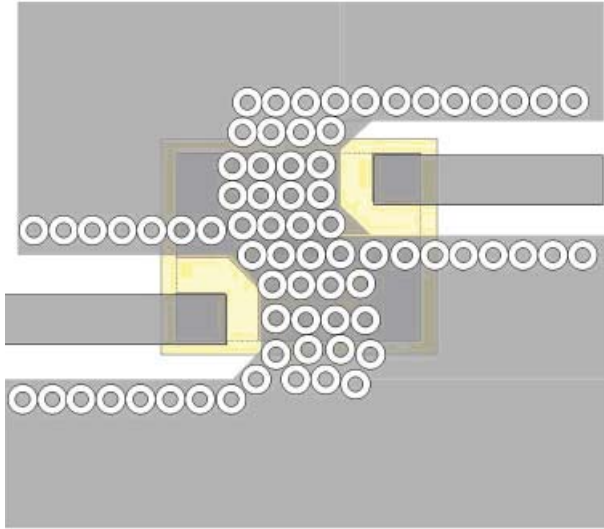
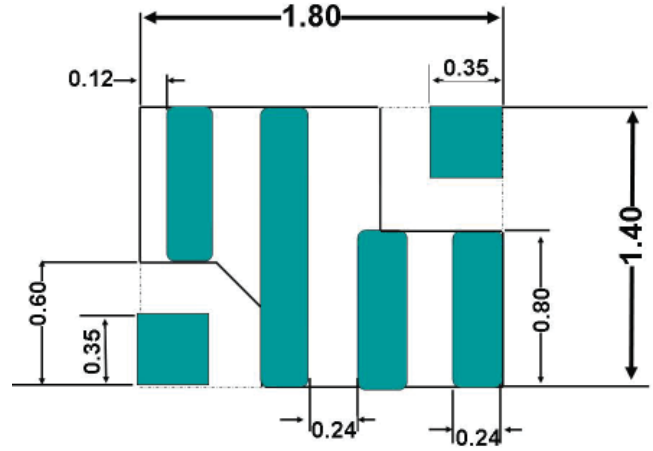

Figure 15. ACPF-8040 Superposed on PCB Layout (top view)



- Notes:
1. Dimensions in mm
  2. Top view
  3. Chamfer or radius all corners 0.05 mm min

Figure 16. Recommended Solder Stencil (top view)

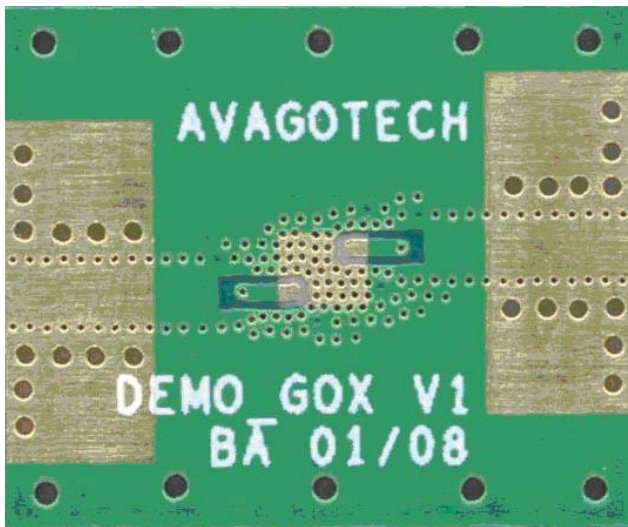

Figure 17. Evaluation board (SMA connectors) for ACPF-8040 (top view)

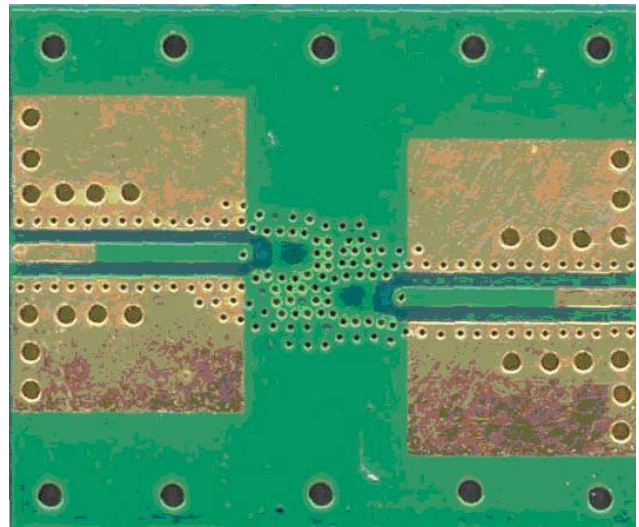
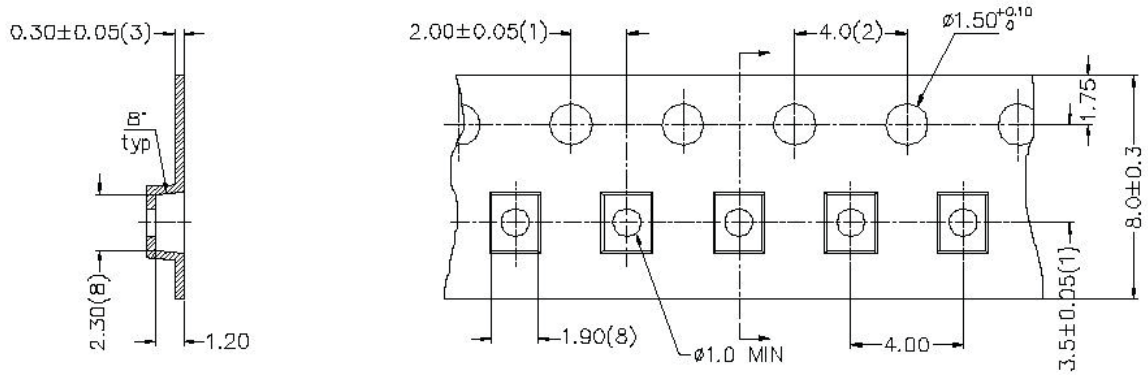

Figure 18. Evaluation board (SMA connectors) for ACPF-8040 (bottom view)

**ACPF-8040**



NOTE:

- (1). MEASURED FROM THE CENTERLINE OF SPROCKET HOLE TO CENTERLINE OF THE POCKET HOLE AND FROM THE CENTERLINE OF SPROCKET HOLE TO CENTERLINE OF THE POCKET
- (2). CUMULATIVE TOLERANCE OF 10 SPROCKET HOLES IS  $\pm 0.20$
- (3). THIS THICKNESS IS APPLICABLE AS MEASURE AT THE EDGE OF THE TAPE.
- 4. MATERIAL: BLACK POLYSTYRENE
- 5. ALL DIMENSIONS IN MM.
- 6. ALLOWABLE CAMBER TO BE 1MM PER 250MM IN LENGTH
- 7. UNLESS OTHERWISE SPECIFIED TOLERANCE  $\pm 0.10$ .
- {8}. MEASUREMENT POINT TO BE 0.3 FROM BOTTOM POCKET.
- 9. SURFACE RESISTIVITY FROM  $1.0 \times 10^5$  TO  $1.0 \times 10^{11}$  OHMS/SQ

USER DIRECTION  
OF UNREELING



**Figure 19. SMD Tape Packing**

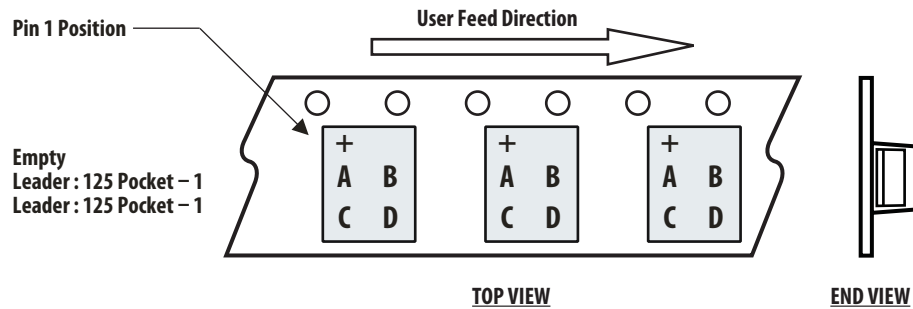

**Figure 20. Orientation in Tape**



# ACPF-8040

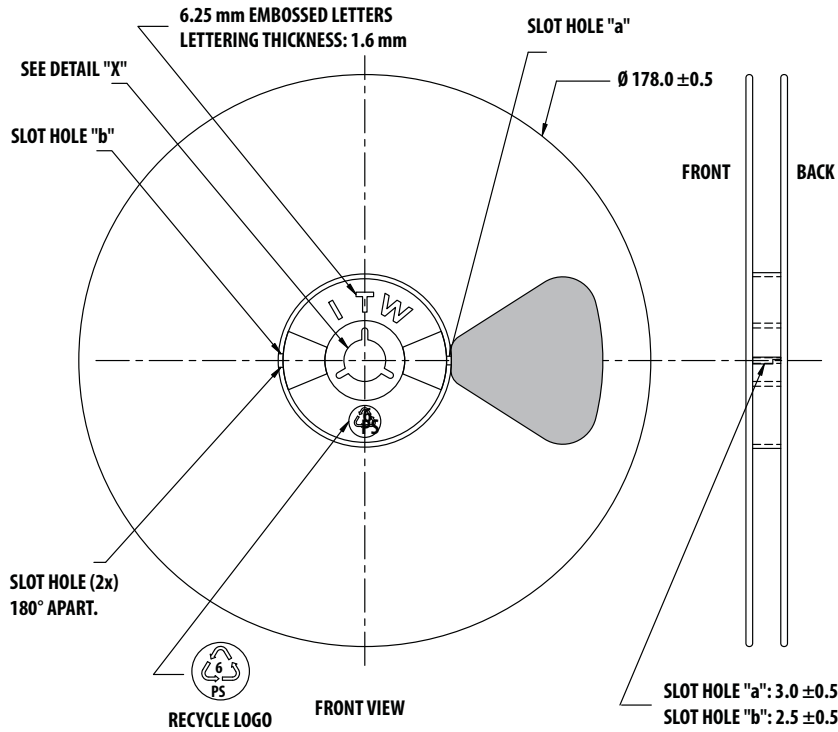

No.	Color	Surface Resistivity
1.	Pantone 285U Dark Blue	Antistatic Coated 10 <sup>6</sup> -10 <sup>11</sup> per Ω square
2.	Black	Conductive <10 <sup>6</sup> per Ω square
3.	White	Antistatic Impregnated 10 <sup>6</sup> -10 <sup>11</sup> per Ω square
4.	Pantone 3295C Dark Green	Antistatic Coated 10 <sup>6</sup> -10 <sup>11</sup> per Ω square
5.	Pantone 186C Dark Red	Antistatic Coated 10 <sup>6</sup> -10 <sup>11</sup> per Ω square
6.	Pantone 278C Light Blue	Antistatic Coated 10 <sup>6</sup> -10 <sup>11</sup> per Ω square
7.	White	Antistatic Coated 10 <sup>6</sup> -10 <sup>11</sup> per Ω square
8.	Natural	Antistatic Coated 10 <sup>6</sup> -10 <sup>11</sup> per Ω square
9.	Pantone 298C-299C Dull Light Blue	Antistatic Coated 10 <sup>6</sup> -10 <sup>11</sup> per Ω square

Note: X in Part Numbering donotes colour code

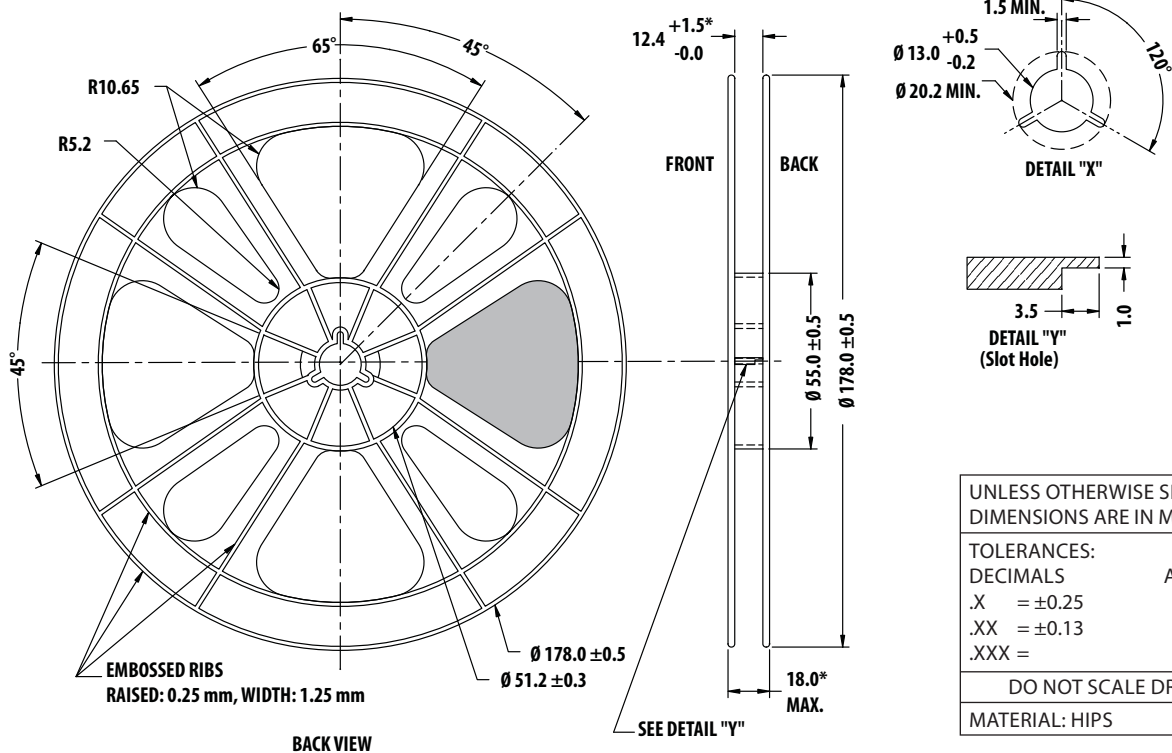

UNLESS OTHERWISE SPECIFIED, DIMENSIONS ARE IN MILLIMETERS	
TOLERANCES:	
DECIMALS	ANGLES
.X = ±0.25	±0.5°
.XX = ±0.13	
.XXX =	
DO NOT SCALE DRAWING	
MATERIAL: HIPS	

## Notes:

1. • Measured at HUB area.
2. All flange edges to be rounded.
3. Marked "Made in Malaysia" outside all carton boxes.
4. Cref Old P/D: H-JE0008-01 & H-JE0012-01

Figure 21. SMT Reel Drawing

## ACPF-8040

### Package Moisture Sensitivity

Feature	Test Method	Performance
Moisture Sensitivity Level (MSL) at 260° C	JESD22-A113D	Level 3

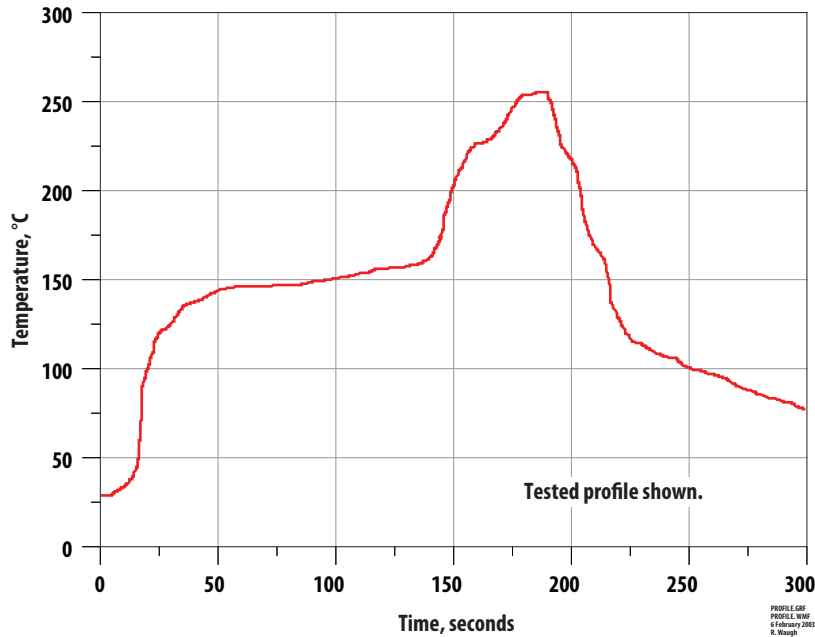

Figure 22. Verified SMT Solder Profile

### Ordering Information

Part Number	No. of Devices	Container
ACPF-8040-BLK	100	Tape Strip or Anti-static Bag
ACPF-8040-TR1	3000	178 mm (7-inch) Reel

For product information and a complete list of distributors, please go to our web site: [www.avagotech.com](http://www.avagotech.com)

Avago, Avago Technologies, and the A logo are trademarks of Avago Technologies in the United States and other countries. Data subject to change. Copyright © 2005-2012 Avago Technologies. All rights reserved.  
AV02-3746EN - October 9, 2012

**AVAGO**  
TECHNOLOGIES