



汽车对应

RoHS指令
适合产品

2方向感知可能本体厚2mm的表面贴装型。

检测

按动

滑动

旋转

编码器

电源

切换

多功能
操作装置

TACT Switch™

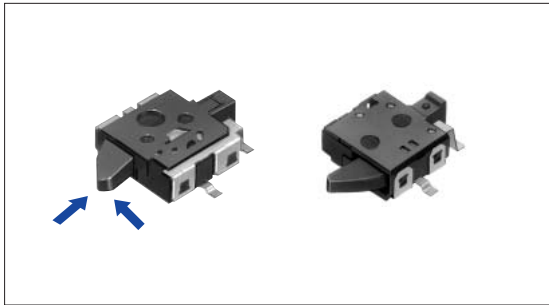
特别定做
产品

特长

- 能从纵・横・斜向按的小形检测开关。
- 适应回流焊接。
- 自印刷电路板安装面起的高度为2mm的薄形。

用途

- DVD录音机误消除防止用
- 汽车导航，汽车音响，CD光碟更换器，CD-RW，CD-ROM等机械感知用
- 笔记本电脑，携带信息终端等盖开关检测用

主要规格





项目		规格
最大额定/最小额定(电阻负荷)		50mA 20V DC/100 μ A 3V DC
接触电阻(初期/寿命后)		500m Ω max./1 Ω max.
动作力		0.4N max.
操作寿命	无负载	100,000 cycles
	负载	100,000 cycles (50mA 20V DC)

产品一览

电路数	接点数	端子形状	扳手的长度	操作方向	定位销	横端子	产品编号	图号
1	1	For PC board (Reflow)	Standard	Right	有	两侧有	SPVG110301	1
						右有	SPVG111500	2
						左有	SPVG111400	3
				Left	有	无	SPVG120302	4
						两侧有	SPVG130200	1
						右有	SPVG210302	5
			Short	Right	有	左有	SPVG211200	6
						无	SPVG211300	7
						无	SPVG220300	8
				Left	有	两侧有	SPVG230200	5
						无	SPVG310300	9
						无	SPVG320200	10
Left	有	两侧有	SPVG330200	9				
		无	SPVG410300	11				
		无	SPVG420200	12				
无	无	无	SPVG430200	11				

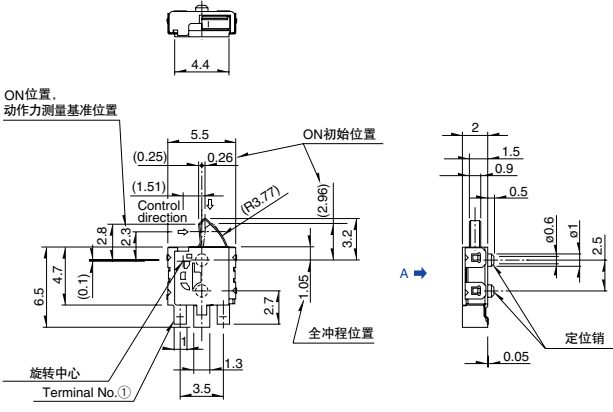
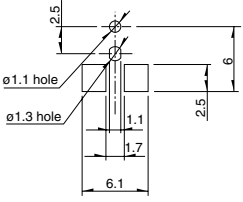
外形图

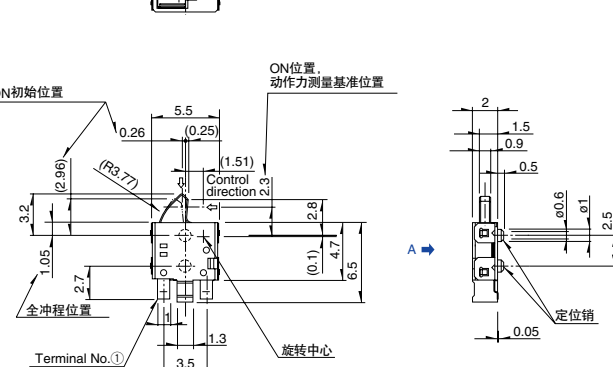
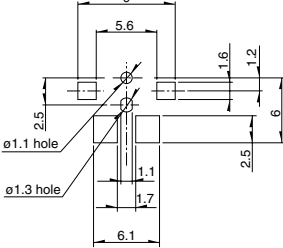
Unit:mm

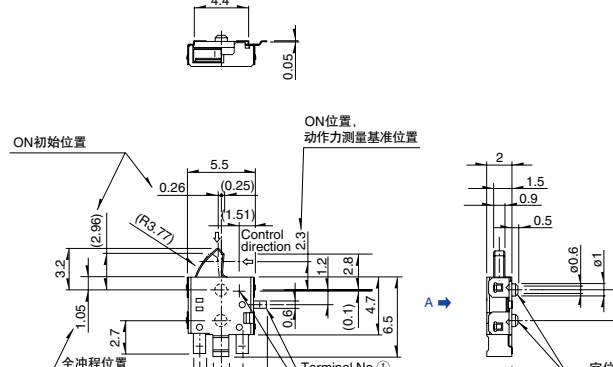
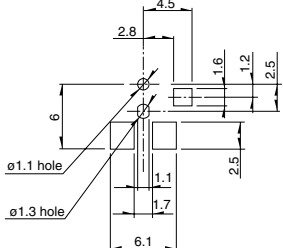
No.	照片	形状	印刷电路板安装孔尺寸图
4	<p>Right operation type</p> 	 <p>ON位置, 动作力测量基准位置</p> <p>ON初始位置</p> <p>Control direction</p> <p>全冲程位置</p> <p>旋转中心</p> <p>Terminal No.①</p>	 <p>ø1.1 hole</p> <p>ø1.3 hole</p>
5	<p>Left operation type</p> 	 <p>ON初始位置</p> <p>ON位置, 动作力测量基准位置</p> <p>Control direction 2</p> <p>全冲程位置</p> <p>旋转中心</p> <p>Terminal No.①</p>	 <p>ø1.1 hole</p> <p>ø1.3 hole</p>
6	<p>Left operation type</p> 	 <p>ON初始位置</p> <p>ON位置, 动作力测量基准位置</p> <p>Control direction</p> <p>全冲程位置</p> <p>旋转中心</p> <p>Terminal No.①</p>	 <p>ø1.1 hole</p> <p>ø1.3 hole</p>

检测

按动

滑动

旋转

编码器

电源

切换





多功能
操作装置

TACT Switch™

特别定做
产品

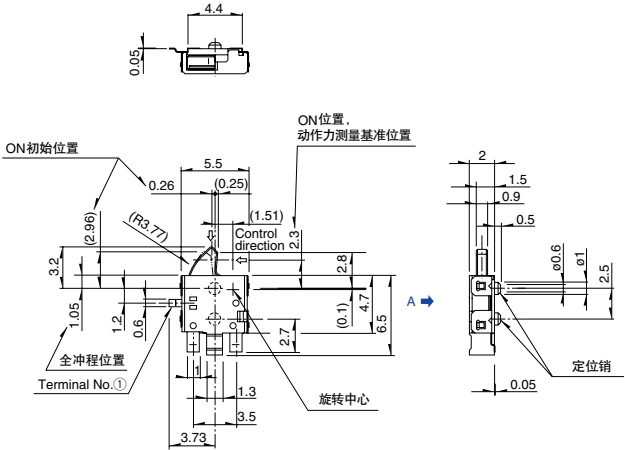
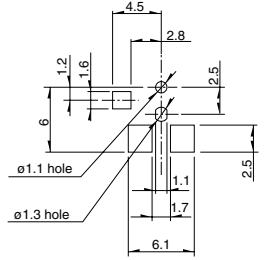
外形图

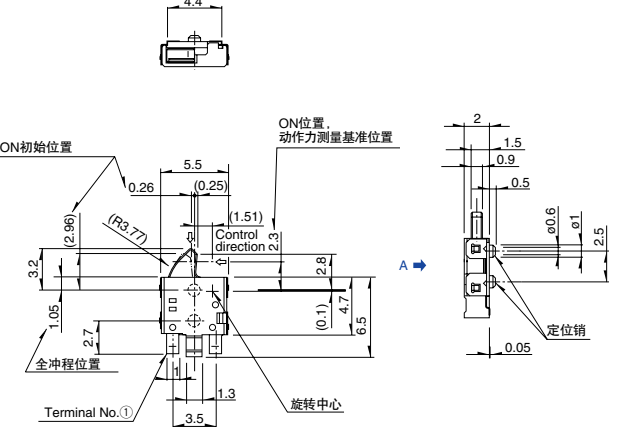
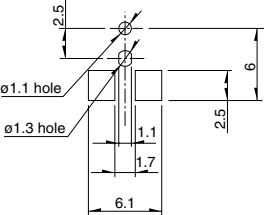
Unit:mm

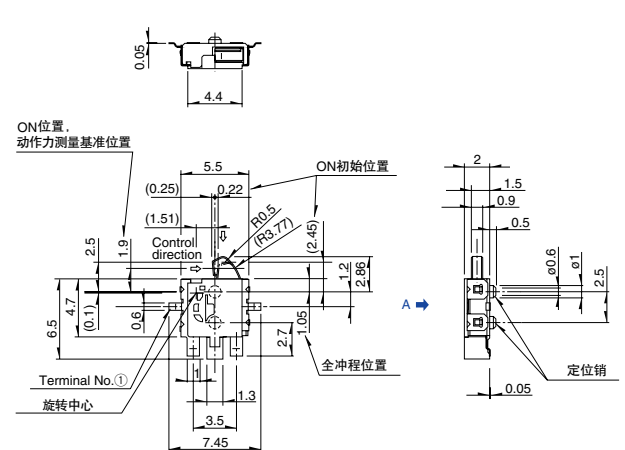
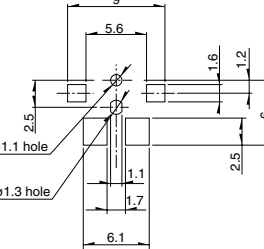
No.	照片	形状	印刷电路板安装孔尺寸图
7	<p>Left operation type</p> 	 <p>ON初始位置 ON位置, 动作力测量基准位置 全冲程位置 Terminal No.① Control direction 旋转中心 定位销</p>	 <p>ø1.1 hole ø1.3 hole 6.1 2.5 1.7 1.1 2.8 4.5</p>
8	<p>Left operation type</p> 	 <p>ON初始位置 ON位置, 动作力测量基准位置 全冲程位置 Terminal No.① Control direction 旋转中心 定位销</p>	 <p>ø1.1 hole ø1.3 hole 6.1 2.5 1.7 1.1 6</p>
9	<p>Right operation type</p> 	 <p>ON位置, 动作力测量基准位置 ON初始位置 全冲程位置 Terminal No.① Control direction 旋转中心 定位销</p>	 <p>ø1.1 hole ø1.3 hole 6.1 2.5 1.7 1.1 1.2 1.6 9 5.6 6</p>

检测

按动

滑动

旋转

编码器

电源

切换





多功能
操作装置

TACT Switch™

特别定做
产品

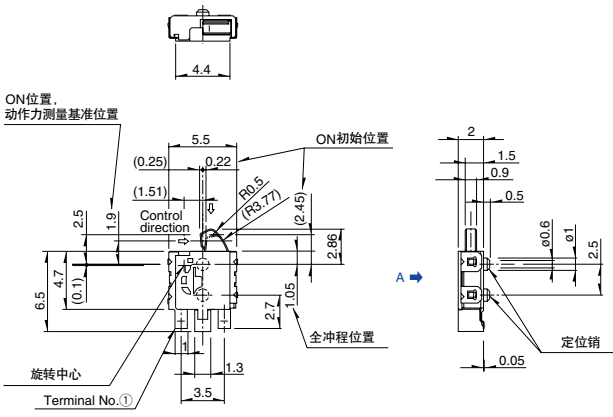
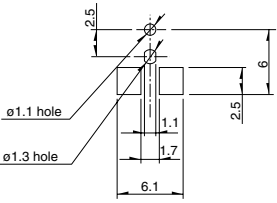
外形图

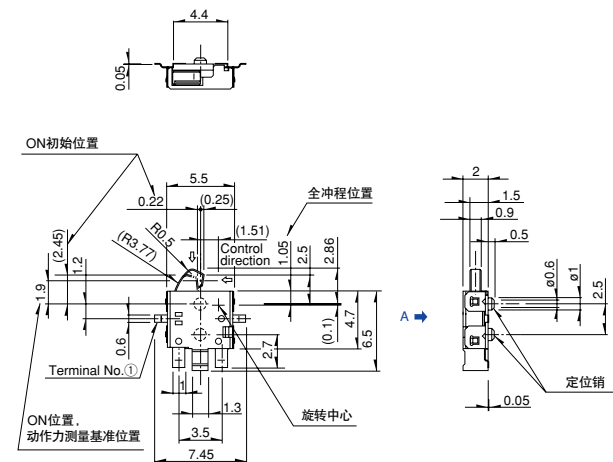
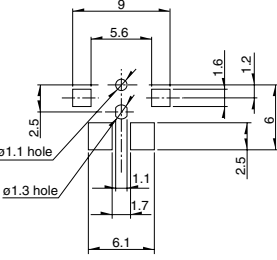
Unit:mm

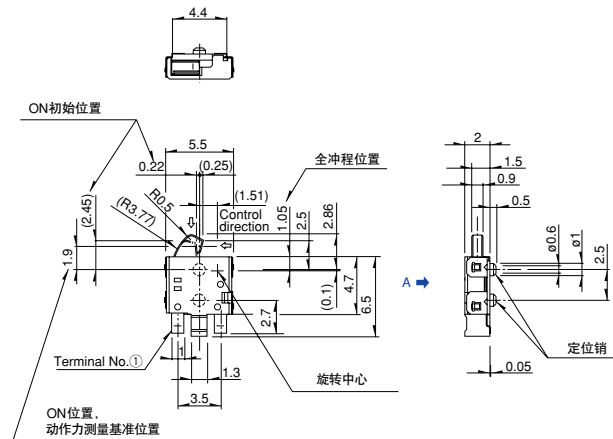
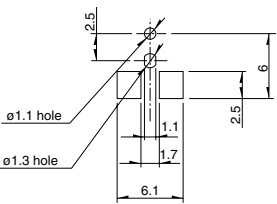
No.	照片	形状	印刷电路板安装孔尺寸图
10	<p>Right operation Type</p> 	 <p>ON位置, 动作力测量基准位置</p> <p>ON初始位置</p> <p>全冲程位置</p> <p>Control direction</p> <p>旋转中心</p> <p>Terminal No.①</p>	 <p>ø1.1 hole</p> <p>ø1.3 hole</p>
11	<p>Left operation Type</p> 	 <p>ON初始位置</p> <p>全冲程位置</p> <p>Control direction</p> <p>旋转中心</p> <p>Terminal No.①</p> <p>ON位置, 动作力测量基准位置</p>	 <p>ø1.1 hole</p> <p>ø1.3 hole</p>
12	<p>Left operation Type</p> 	 <p>ON初始位置</p> <p>全冲程位置</p> <p>Control direction</p> <p>旋转中心</p> <p>Terminal No.①</p> <p>ON位置, 动作力测量基准位置</p>	 <p>ø1.1 hole</p> <p>ø1.3 hole</p>

注记

在外形图中只表示有定位销的形状。

- 检测
- 按动
- 滑动
- 旋转
- 编码器
- 电源
- 切换
- 多功能操作装置
- TACT Switch™
- 特别定做产品

■ 端子排列 (自A方向看)

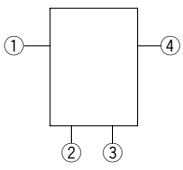
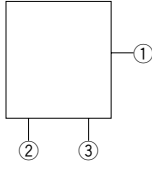
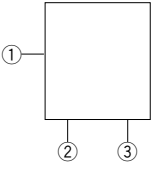
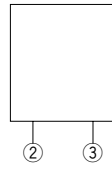
<p>图号: 1, 5, 9, 11</p> 	<p>图号: 2, 6</p> 
<p>图号: 3, 7</p> 	<p>图号: 4, 8, 10, 12</p> 

■ 电路图

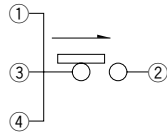
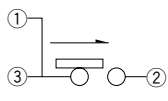
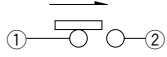
<p>图号: 1, 5, 9, 11</p> 	<p>图号: 2, 3, 6, 7</p> 
<p>图号: 4, 8, 10, 12</p> 	

产品规格

系列		SPVP	SPVC1	SPVN	SPVS	SPVG	SSCW	SPVL	SPVQ1	SPVQ3	SPVQ4	SSCN	
项目													
使用温度范围		-10°C to +60°C					-40°C to +85°C	-10°C to +60°C	-40°C to +85°C				
最大额定(电阻负荷)		1mA 5V DC	10mA 16V DC	1mA 5V DC	50mA 20V DC	0.1A 12V DC	1mA 5V DC	0.1A 12V DC					
电性能	初期接触电阻	5Ω max.	1Ω max.	2Ω max.	500mΩ max.		2Ω max.	500mΩ max.					
	绝缘电阻	100MΩ min. 100V DC				100MΩ min. 250V DC	100MΩ min. 100V DC	100MΩ min. 500V DC					
	耐电压	100V AC for 1 min.				250V AC for 1 min.	100V AC for 1 min.	500V AC for 1 min.					
机械性能	端子强度	0.5N for 1 min.	3N for 1 min.	0.5N for 1 min.		—	1N for 1 min.	3N for 1 min.					
	操作部强度	5N	10N	5N	10N	20N	5N	20N			10N		
	耐振性能	10~55~10Hz/分,全振幅 1.5mm、X.Y.Z 3方向 各2小时											
焊接 耐热性能	手焊接	350±5°C, 3s max.	350±10°C, 3 ⁺¹ ₋₀ s	350±5°C, 3s max.		—	350±5°C, 3s max.	300±10°C, 3 ⁺¹ ₋₀ s					
	浸焊	—	260±5°C, 3s max.	—			—		260±5°C, 5±1s			—	
	回流焊接	请参照 P.72	—	请参照P.72		—	请参照 P.72	—					
耐久性能	无负荷寿命	50,000 cycles 10Ω max.	25,000 cycles 2Ω max.	50,000 cycles 5Ω max.		100,000 cycles 1Ω max.	50,000 cycles 5Ω max.	300,000 cycles 1Ω max.	300,000 cycles or 1,000,000 cycles 1Ω max.	300,000 cycles 1Ω max.	100,000 cycles 1Ω max.		
	负荷寿命	(1mA 5V DC) 50,000 cycles 10Ω max.	(10mA 16V DC) 25,000 cycles 2Ω max.	(1mA 5V DC) 50,000 cycles 5Ω max.		(50mA 20V DC) 100,000 cycles 1Ω max.	(0.1A 12V DC) 100,000 cycles 1Ω max.	(1mA 5V DC) 50,000 cycles 5Ω max.	(0.1A 12V DC) 300,000 cycles 1Ω max.	(0.1A 12V DC) 300,000 cycles or 1,000,000 cycles 1Ω max.	(0.1A 12V DC) 300,000 cycles 1Ω max.	(0.1A 12V DC) 100,000 cycles 1Ω max.	
耐环境性能	耐寒性能	-20±2°C for 96h				-40±2°C for 96h	-40±2°C for 500h	-20±2°C for 96h	-40±2°C for 500h				
	耐热性能	85±2°C for 96h				85±2°C for 500h	85±2°C for 96h	85±2°C for 500h					
	耐湿性能	40±2°C, 90 to 95%RH for 96h				60±2°C, 90 to 95%RH for 500h	40±2°C, 90 to 95%RH for 96h	60±2°C, 90 to 95%RH for 500h					

焊接条件

回流方式的参考举例

1. 加热方式 为由远红外线加热的上下加热方式。
2. 温度测量方式 用 $\phi 0.1 \sim \phi 0.2$ 的CA(K)或CC(T)进行测量。在焊接的连接部位置(铜箔面)测量，固定方式使用耐热胶带。
3. 温度分布

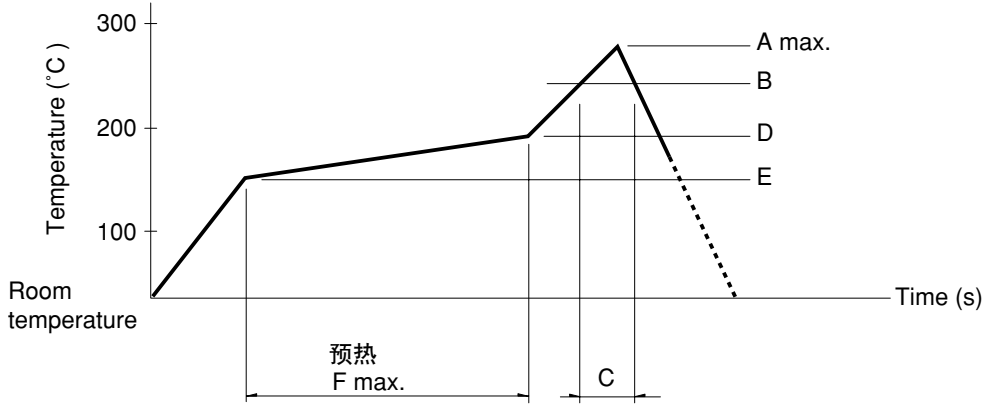

Series (Reflow type)	A (°C) 3s max.	B (°C)	C (s)	D (°C)	E (°C)	F (s)
SPPB	250	230	40			
SPPW8		200	20			
SPVE	260	230	40	180	150	120
SPVG						
SPVL						
SPVM						
SPVN						
SPVP						
SPVR						
SPVS						
SSCM						
SPPY5						

注记

1. 上述条件，为印刷电路板的零部件贴装面上的温度，根据电路板的材质、大小、厚度等，电路板温度和开关表面温度会有很大的不同，关于开关表面温度，也请在上述条件内使用。
2. 根据回流槽的种类、条件稍有不同，请事先充分进行确认之后使用。

检测

按动

滑动

旋转

编码器

电源

切换

多功能
操作装置

TACT Switch™

特别定做
产品

捆包规格

贴纸包装

卷盘尺寸

Unit:mm

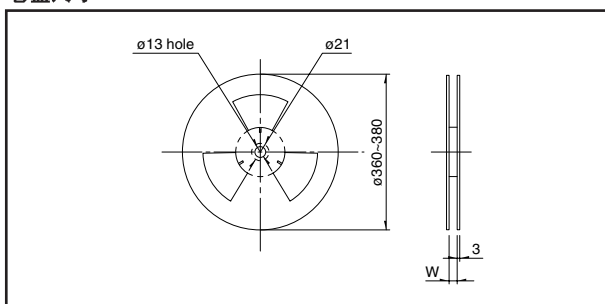

系列		包装数 (pcs.)			卷盘宽度 (mm)	贴纸宽度 (mm)	
		1卷	1箱/国内	1箱/出口包装			
SPPB	53 (Horizontal)	1,500	3,000	6,000	24.4	24	
	53 (Vertical)	600	1,200	2,400			
	63, 64	1,300	2,600	5,200			
SPPW81	h = 6.1 (Reflow)	1,000	2,000	4,000	12.4	12	
	h = 6.55 (Reflow)						
	h = 7.6 (Reflow)	850	1,700	3,400			
SPVE	Standard	h=3.8	2,800	5,600	22,400	16.4	16
		h=4.1					
		h=4.8	2,200	4,400	17,600		
		h=5.2	2,000	4,000	16,000		
		h=5.5					
	Low-profile	h=3.3	2,800	5,600	22,400		
SPVG		2,500	5,000	10,000	44.4	44	
SPVL		5,000	10,000	20,000			
SPVM		3,000	6,000	12,000			
SPVN		5,000	10,000	20,000			
SPVP		4,500	9,000	18,000			
SPVR		2,500	5,000	10,000			
SPVS		5,000	10,000	20,000			
SSCM		3,000	6,000	12,000			
SPPY5		550	1,650	3,300			

注记

贴纸品，请以最小包装单位(1卷,1箱)的N倍定货。

检测

按动

滑动

旋转

编码器

电源

切换

多功能
操作装置

TACT Switch™

特别定做
产品