

System Reset Monolithic IC PST70XX Series

Outline

These low reset type ICs function in a variety of CPU systems and other logic systems, to detect power supply voltage and reset the system accurately when power is turned on or interrupted.

They are ideal for use in battery check circuits for products using batteries, as they have ultra-low current consumption and a high precision voltage detection function.

Features

- | | |
|--|---|
| 1. High precision voltage detection | $V_s \pm 2\%$ max. |
| 2. Ultra-low current consumption | $I_{CCH} = 2\mu A$ typ. $I_{CCL} = 3\mu A$ typ. |
| 3. Low operating limit voltage | 0.65V typ. |
| 4. Hysteresis voltage provided in detection voltage | 50mV typ. |
| 5. Output current high for ON | 30mA typ. |
| 6. Detection voltage can be selected as desired within a range of 1.9V~4.6V in 0.1V steps, as indicated below. | |

PST70XX

└───┬───┘ Detection voltage value

(Example: for 4.6V PST7046)

Package

MMP-3A (PST70 × × M)

TO-92A (PST70 × ×)

Applications

1. Reset circuits in microcomputers, CPUs and MPUs.
2. Logic circuit reset circuits.
3. Battery voltage check circuits.
4. Back-up power supply switching circuits.
5. Level detection circuits.

Pin Assignment

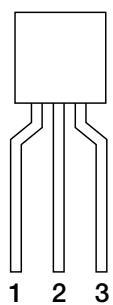

TO-92A

1	V_{CC}
2	GND
3	V_{OUT}

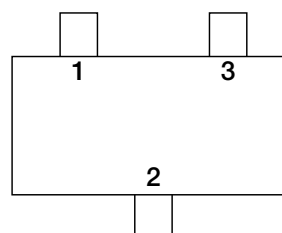

MMP-3A

1	V_{CC}
2	GND
3	V_{OUT}

Equivalent Circuit Diagram

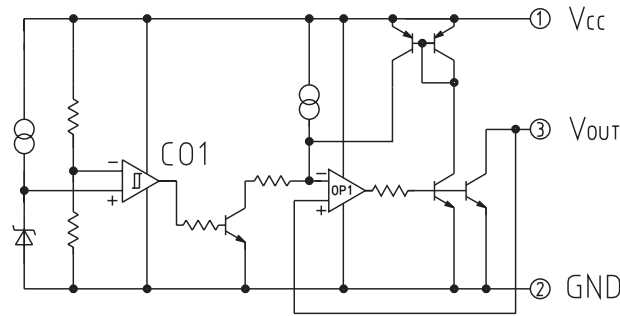

Absolute Maximum Ratings (Ta=25°C)

Item	Symbol	Rating	Units
Storage temperature	T _{STG}	-40~+125	°C
Operating temperature	T _{OPR}	-20~+75	°C
Power supply voltage	V _{CC} max.	-0.3~10	V
Allowable loss	P _d	200 (MMP-3A) 300 (TO-92A)	mW

Electrical Characteristics (Ta=25°C)

Item	Symbol	Measurement conditions	Measurement circuit	Min.	Typ.	Max.	Units
Detection voltage	V _s	R _L =470Ω V _{CC} =H→L	1	V _s typ. -2%	4.6~ 1.9 (0.1V Step)	V _s typ. +2%	V
Hysteresis voltage	ΔV _s	R _L =470Ω	1	30	50	100	mV
Detection voltage temperature coefficient	V _s /ΔT	R _L =470Ω	1		±0.01		%/°C
Low-level output voltage	V _{OL}	V _{CC} =V _s min. -0.05V R _L =470Ω	1		0.2	0.4	V
Output leakage current	I _{OH}	V _{CC} =10.0V	1			0.1	μA
Circuit current while on	I _{CCL}	V _{CC} =V _s min. -0.05V R _L =∞	1		3.0	6.0	μA
Circuit current while off	I _{CCH}	V _{CC} =V _s typ. /0.85V R _L =∞	1		2.0	4.0	μA
"H"transport delay time	t _{PLH}	R _L =4.7kΩ	7046~24	2	5	30	μS
		C _L =100P	7023~19	2	10	30	
"L"transport delay time	t _{PHL}	R _L =4.7kΩ	7046~24	2	30	70	μS
		C _L =100P	7023~19	2	70	150	
Operation limit voltage	V _{OPL}	R _L =4.7kΩ V _{OL} ≤ 0.4V	1		0.65	0.85	V
Output current while on 1	I _{OL1}	V _{CC} =V _s min. -0.05V R _L =0Ω	1	8	30		mA
Output current while on 2	I _{OL2}	T _a =-20°C~+75°C	1	5			mA

Measuring Circuit

[1]

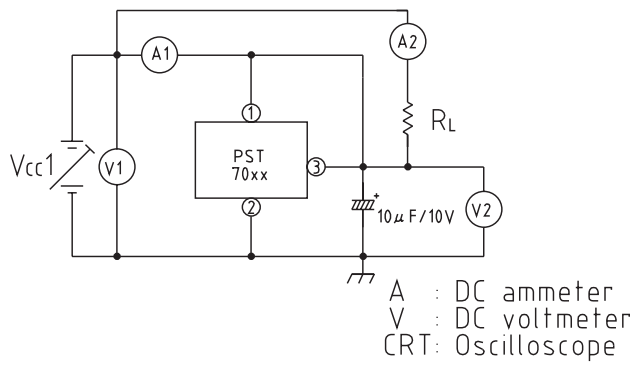

[2]

