

## 1.5A High Output Current LDO Regulator

### ❖ GENERAL DESCRIPTION

The AX6642/A is a low noise, high output current, low quiescent current and low dropout linear regulator. The Device includes pass element, error amplifier, band-gap, current-limit and thermal shutdown circuitry. The output current is up to 1.5A. The characteristics of low dropout voltage and less quiescent current make it good for some critical current application, for example, some battery powered devices. The typical quiescent current is approximately 50 $\mu$ A. Due to internal flexible design; result in extensively fixed output voltage versions form 1.2V to 5V per 0.1V steps. Built-in current-limit, Short current protection and thermal-shutdown functions prevent any fault condition from IC damage.

### ❖ FEATURES

- Input voltage range : 2.6V~5.5V
- Dropout voltage is 450mV at 1.5A output current @  $V_{OUT} = 3.30V$
- Guaranteed 1.5A output current
- Low quiescent current is 50 $\mu$ A (typ.)
- Fixed Output voltage is form 1.2 V to 5V by 0.1V steps.
- Fast transient response
- Current limit and thermal shutdown protection
- Short circuit current fold-back
- Available in the 3-Pin Pb-Free SOT89, SOT-223, TO263, TO252 and SOP-8L packages

### ❖ BLOCK DIAGRAM

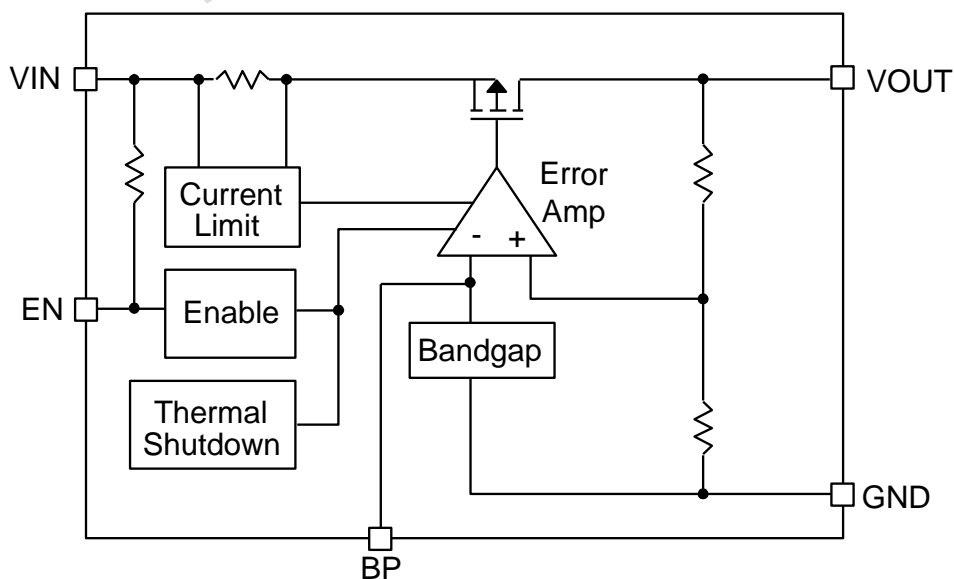

❖ PIN ASSIGNMENT

The packages of AX6642/A are SOT89-3L, SOT223-3L, TO252-3L, TO263-2L and SOP-8L; the pin assignment is given by:

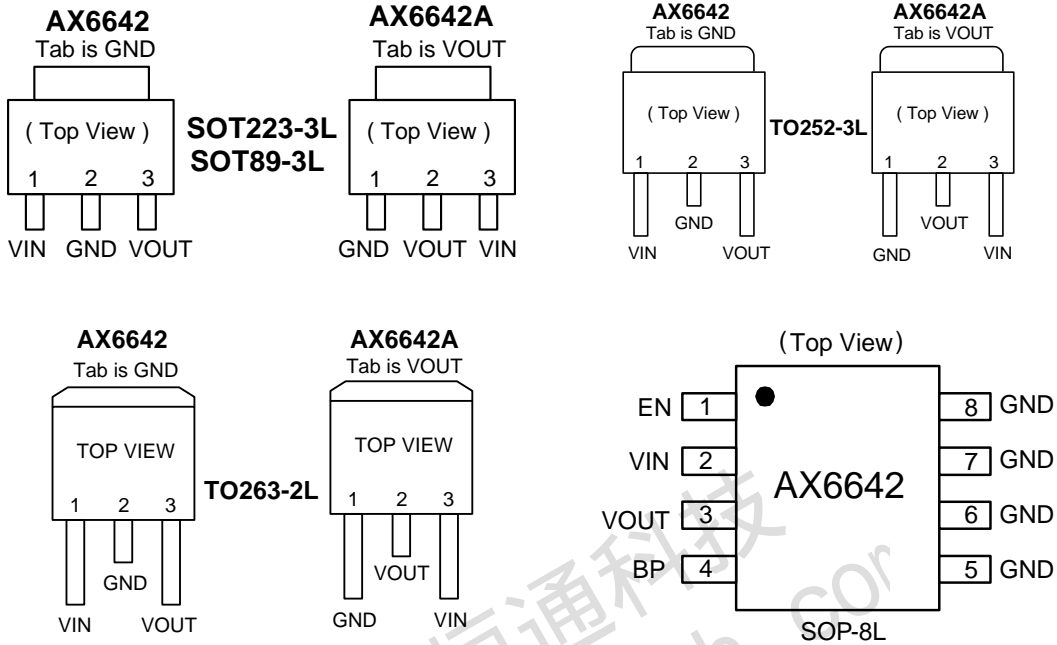

Name	Description
VIN	Voltage input
GND	Ground
VOUT	Output Voltage
EN	Active-Low Shutdown Input. A logic low reduces the supply current to less than 2μA. Connect to V <sub>IN</sub> or Floating for normal operation. (SOP-8L only)
BP	Band-gap (SOP-8L only)

❖ ORDER/MARKING INFORMATION

Order Information	
<b>AX6642 X - XXX X X</b>	
<div style="display: flex; justify-content: space-around;"> <div style="border: 1px solid black; padding: 5px;">Pin Define</div> <div style="border: 1px solid black; padding: 5px;">Output voltage</div> <div style="border: 1px solid black; padding: 5px;">Package</div> <div style="border: 1px solid black; padding: 5px;">Packing</div> </div>	
Refer Pin Assignment	100 : 1.0V 110 : 1.1V ⋮ 500 : 5.0V
	E : SOT223-3L D:TO252-3L M:TO263-2L F:SOT89-3L S:SOP-8L
	Blank:Tube A : Taping
Top Marking (SOT223-3L)	Top Marking (SOT89-3L)
<p>Blank: AX6642 A: AX6642A</p>	<p>Output Type: A:1.2V H:1.9V Q:2.6V X:3.3V f:4.0V r:4.7V B:1.3V J:2.0V R:2.7V Y:3.4V g:4.1V t:4.8V C:1.4V K:2.1V S:2.8V Z:3.5V h:4.2V u:4.9V D:1.5V L:2.2V T:2.9V a:3.6V m:4.3V y:5.0V E:1.6V M:2.3V U:3.0V b:3.7V n:4.4V F:1.7V N:2.4V V:3.1V d:3.8V o:4.5V G:1.8V P:2.5V W:3.2V e:3.9V q:4.6V</p>
Top Marking (TO252-3L/TO263-2L)	Top Marking (SOP-8L)
<p>Blank: AX6642 A: AX6642A</p>	<p>Blank: AX6642 A : AX6642A</p>

**❖ ABSOLUTE MAXIMUM RATINGS** (at  $T_A=25\text{ }^\circ\text{C}$ )

Characteristics	Symbol	Rating	Unit
$V_{IN}$ Pin Voltage	$V_{IN}$	GND - 0.3 to GND +6.5	V
Output Voltage	$V_{OUT}$	GND - 0.3 to $V_{IN} +0.3$	V
EN and BP	$V_{EN}, V_{BP}$	GND -0.3 to $V_{IN} +0.3$	V
Power Dissipation	PD	SOT89=0.6,SOT223=1.3 TO263=4,TO252=2.2,SOP-8=1.4	W
Storage Temperature Range	$T_{ST}$	-40 to +150	$^\circ\text{C}$
Operating Temperature Range	$T_{OP}$	-40 to +85	$^\circ\text{C}$
Junction Temperature	$T_J$	-40 to +125	$^\circ\text{C}$
Thermal Resistance from Junction to case	SOT223	$\theta_{JC}$	$^\circ\text{C/W}$
	TO263		
	TO252		
	SOT89		
	SOP-8		
Thermal Resistance from Junction to ambient	SOT223	$\theta_{JA}$	$^\circ\text{C/W}$
	TO263		
	TO252		
	SOT89		
	SOP-8		

Note:  $\theta_{JA}$  is measured with the PCB copper area of approximately 1 in<sup>2</sup>(Multi-layer). That need connect to tap pin.

**❖ ELECTRICAL CHARACTERISTICS**  $T_A=25\text{ }^\circ\text{C}$  (unless otherwise noted)

Characteristics	Symbol	Conditions	Min	Typ	Max	Units	
Input Voltage	$V_{IN}$	$I_{OUT}=30\text{mA}$	2.6	-	5.5	V	
Output Voltage Accuracy (Note 1)	$\Delta V_{OUT}$	$V_{IN}=V_{OUT}+0.1\text{V}$ to 5.5V $V_{OUT} \geq 2.5\text{V}$ , $I_{OUT}=1\text{mA}$	-2	-	+2	%	
		$V_{IN}=2.6\text{V}$ to 5.5V $2.5\text{V} > V_{OUT} \geq 1.20\text{V}$ , $I_{OUT}=1\text{mA}$	-3	-	+3		
Quiescent Current	$I_Q$	$I_{OUT}=0\text{mA}$ , $V_{IN}=5\text{V}$	-	50	80	$\mu\text{A}$	
Shutdown Current	$I_{SD}$	$I_{OUT}=0\text{mA}$ , $V_{EN}=0\text{V}$	-	-	2	$\mu\text{A}$	
Dropout Voltage	$V_{DROP}$	$I_{OUT}=1.5\text{A}$	$V_{OUT}=1.20\text{V}$	-	1.3	1.7	V
			$V_{OUT}=1.50\text{V}$	-	1.0	1.4	
			$V_{OUT}=1.80\text{V}$	-	0.7	1.1	
			$V_{OUT}=2.50\text{V}$	-	0.55	0.75	
			$V_{OUT}=3.30\text{V}$	-	0.45	0.65	
Current Limit (Note 2)	$I_{LIMIT}$		1.6	2.0	-	A	
Short Circuit Current	$I_{SHORT}$	Output Voltage < 0.25* $V_{OUT}$	-	600	-	mA	
Load Regulation (Note 3)	$\Delta V_{LOAD}$	$I_{OUT}=10\text{m}\sim 1.5\text{A}$	$2.0\text{V} > V_{OUT}$	-	10	20	mV
			$2.0\text{V} \leq V_{OUT}$	-	0.5	1	%
Ripple Rejection	PSRR	$C_{IN}=2.2\mu\text{F}$ , $C_O=2.2\mu\text{F}$ , $I_{OUT}=10\text{mA}$	F=120Hz	-	65	-	dB
			F=1KHz	-	60	-	
Enable Input Threshold	$V_{ENH}$	Regulator Enable	2.0	-	-	V	

(SOP-8L only)	$V_{ENL}$	Regulator Shutdown	-	-	0.6	
Enable Pin Current (SOP-8L only)	$I_{ENH}$	$V_{EN}=V_{IN}$	-	0.003	0.1	$\mu A$
	$I_{ENL}$	$V_{EN}=0V$	-	1	1.5	
Temperature Shutdown	$T_S$		-	150	-	$^{\circ}C$
Temperature Shutdown Hysterisis	$T_{SH}$		-	30	-	$^{\circ}C$

Note1: Minimum  $V_{IN}$  voltage is defined by output adds a dropout voltage.

Note2: Current limit is measured at constant junction temperature by using pulsed testing with a low ON time.

Note3: Regulation is measured at constant junction temperature by using pulsed testing with a low ON time.

## ❖ APPLICATION CIRCUIT

### 1. For SOT223-3L/SOT89-3L/TO252-3L/TO263-2L packages

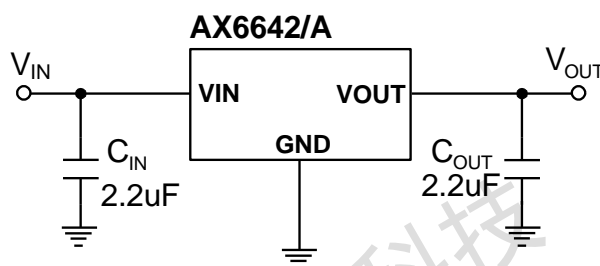

### 2. For SOP-8L package

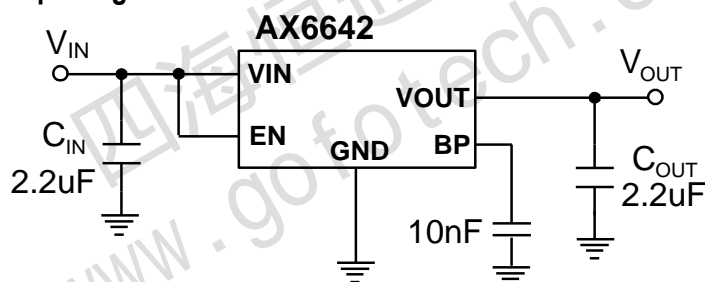

## ❖ FUNCTION DESCRIPTIONS

A minimum of 2.2 $\mu F$  capacitor must be connected from  $V_{OUT}$  to ground to insure stability. Typically a large storage capacitor is connected from  $V_{IN}$  to ground to ensure that the input voltage does not sag below the minimum dropout voltage during the load transient response. This pin must always be dropout voltage higher than  $V_{OUT}$  in order for the device to regulate properly.

## ❖ APPLICATION INFORMATION

Like any low-dropout regulator, the AX6642/A requires input and output decoupling capacitors. The device is specifically designed for portable applications requiring minimum board space and smallest components. These capacitors must be correctly selected for good performance. Please note that linear regulators with a low dropout voltage have high internal loop gains which require care in guarding against oscillation caused by insufficient decoupling capacitance.

### Capacitor Selection

Normally, use a 2.2 $\mu$ F capacitor on the input and a 2.2 $\mu$ F capacitor on the output of the AX6642/A. Larger input capacitor values and lower ESR (X5R, X7R) provide better supply-noise rejection and transient response. A higher- value output capacitor (4.7 $\mu$ F) may be necessary if large, fast transients are anticipated and the device is located several inches from the power source.

### Input-Output (Dropout) Voltage

A regulator's minimum input-to-output voltage differential (dropout voltage) determines the lowest usable supply voltage. In battery-powered systems, this determines the useful end-of-life battery voltage. Because the device uses a PMOS, its dropout voltage is a function of drain-to source on-resistance,  $R_{DS(ON)}$ , multiplied by the load current:

$$V_{DROPOUT} = V_{IN} - V_{OUT} = R_{DS(ON)} \times I_{OUT}$$

### Current Limit and Short-Circuit Protection

The AX6642/A used a current sense-resistor to monitor the output current. A portion of the PMOS output transistor's current is mirrored to a resistor such that the voltage across this resistor is proportional to the output current. Once the output current exceeds limit threshold, AX6642/A would be protected with a limited output current. Further more, when the output is short to ground, the output current would be folded-back to a less limit.

### Thermal Considerations

The AX6642/A series can deliver a current of up to 1.5A over the full operating junction temperature range. However, the maximum output current must be dated at higher ambient temperature to ensure the junction temperature does not exceed 125°C. With all possible conditions, the junction temperature must be within the range specified under operating conditions. Power dissipation can be calculated based on the output current and the voltage drop across regulator.

$$PD = (V_{IN} - V_{OUT}) I_{OUT}$$

The final operating junction temperature for any set of conditions can be estimated by the following thermal equation:

$$PD (MAX) = (T_{J(MAX)} - T_A) / \theta_{JA}$$

Where  $T_{J(MAX)}$  is the maximum junction temperature of the die (125°C) and  $T_A$  is the maximum ambient temperature. The junction to ambient thermal resistance ( $\theta_{JA}$ ) for SOT223-3L package at recommended minimum footprint is 75°C/W (please refer Maximum rating table) that is connected 1 in<sup>2</sup> PCB copper area to tap pin.

### PCB Layout

An input capacitance of  $\cong 2.2\mu\text{F}$  is required between the AX6642/A input pin and ground (the amount of the capacitance may be increased without limit), this capacitor must be located a distance of not more than 1cm from the input and return to a clean analog ground. Input capacitor can filter out the input voltage spike caused by the surge current due to the inductive effect of the package pin and the printed circuit board's routing wire. Otherwise, the actual voltage at the VIN pin may exceed the absolute maximum rating. The output capacitor also must be located a distance of not more than 1cm from output to a clean analog ground. Because it can filter out the output spike caused by the surge current due to the inductive effect of the package pin and the printed circuit board's routing wire.

四海恒通科技  
www.gofotech.com

❖ TYPICAL CHARACTERISTICS

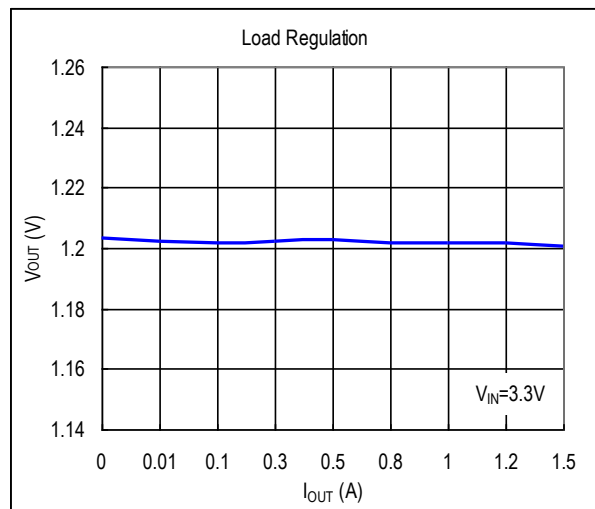
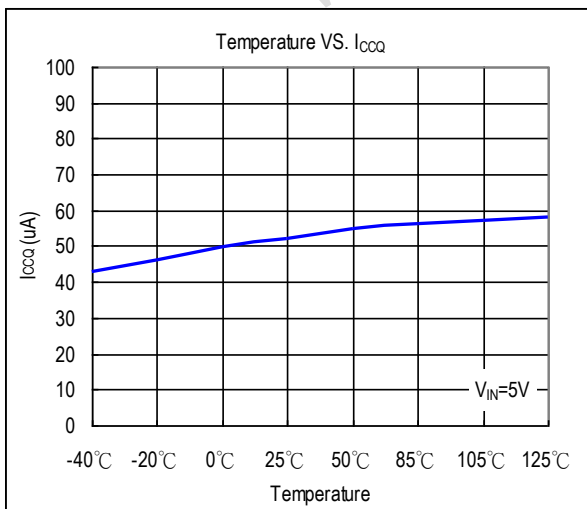
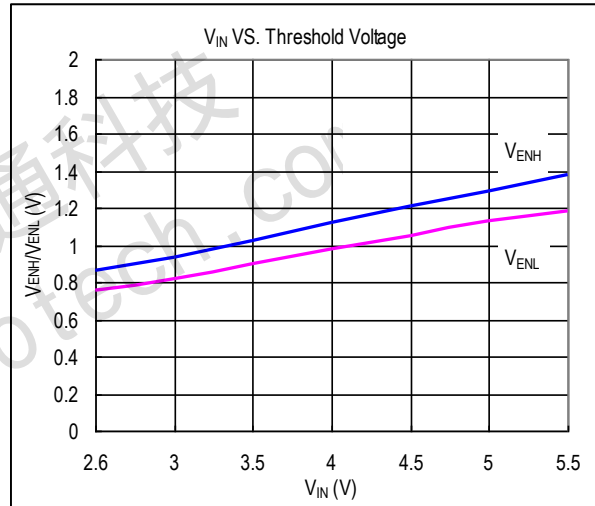
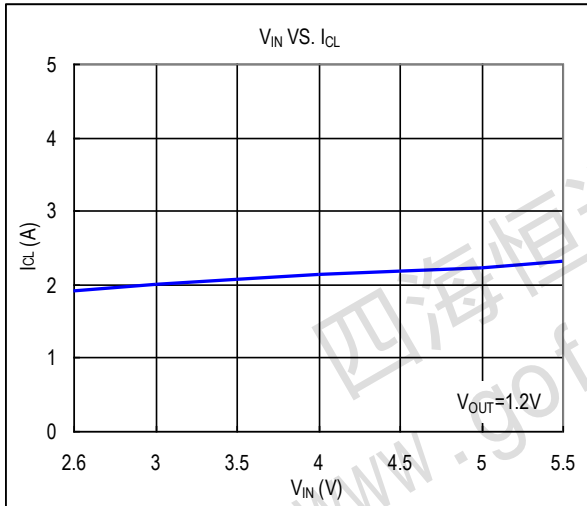
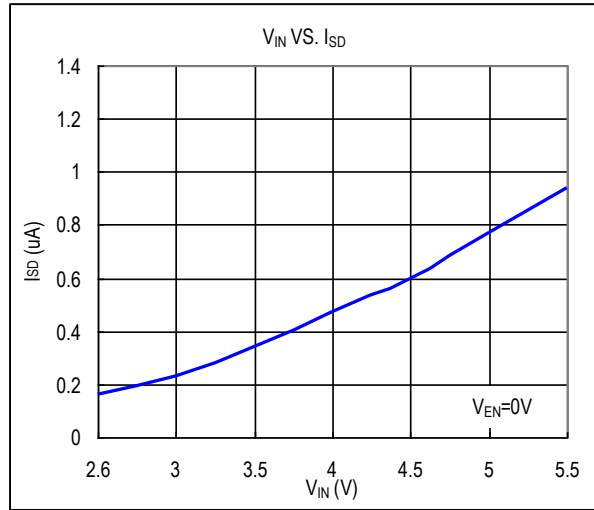
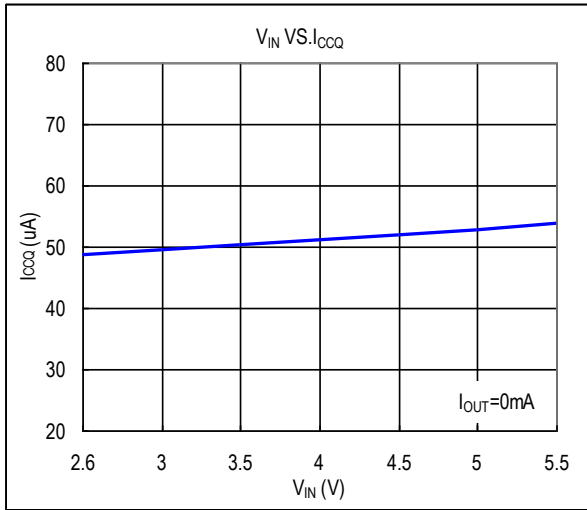



❖ TYPICAL CHARACTERISTICS (CONTINUOUS)

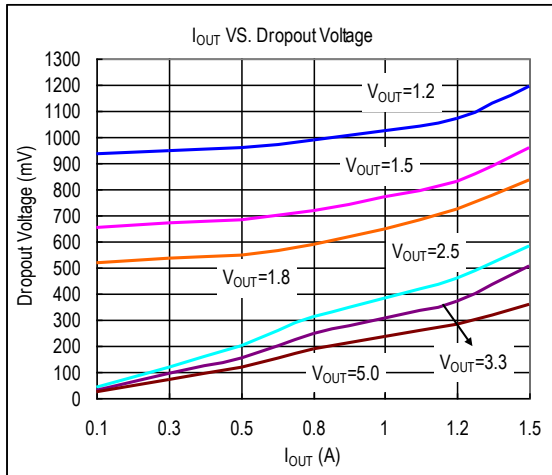

Power-ON

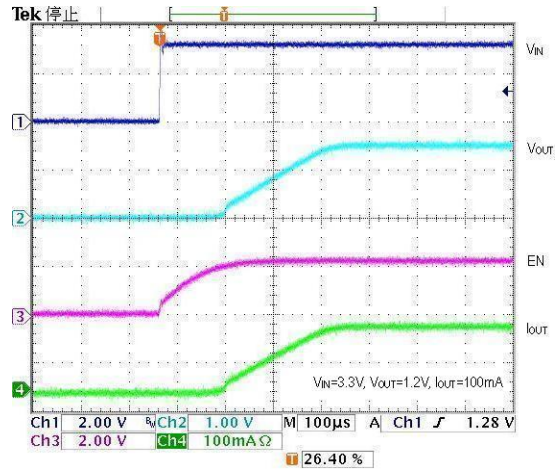

EN-ON (SOP-8L Only)

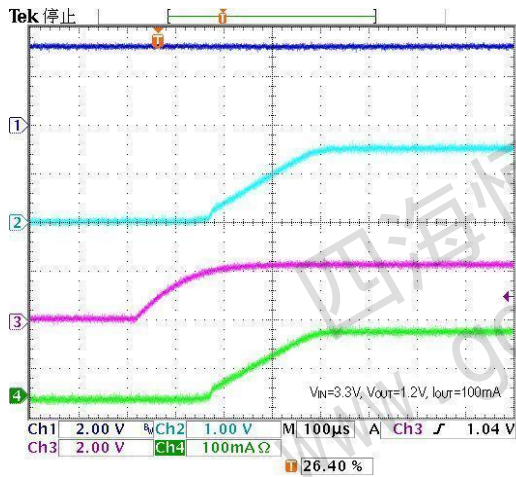

Load Transient

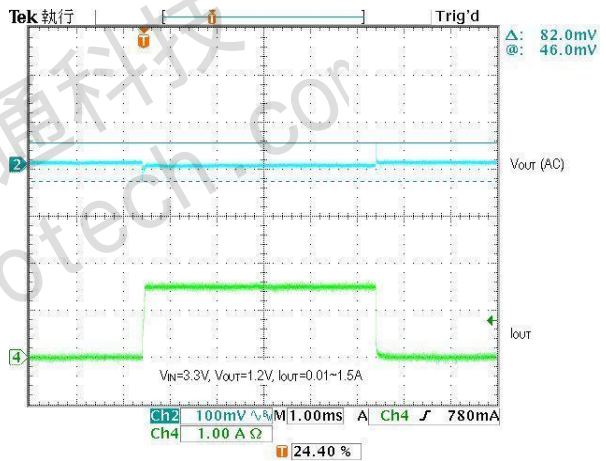

Thermal Shutdown Release

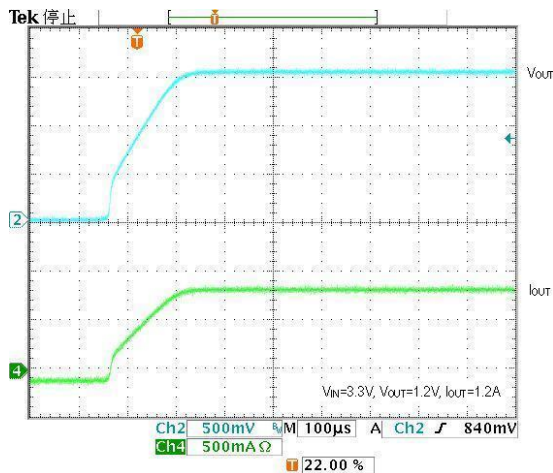

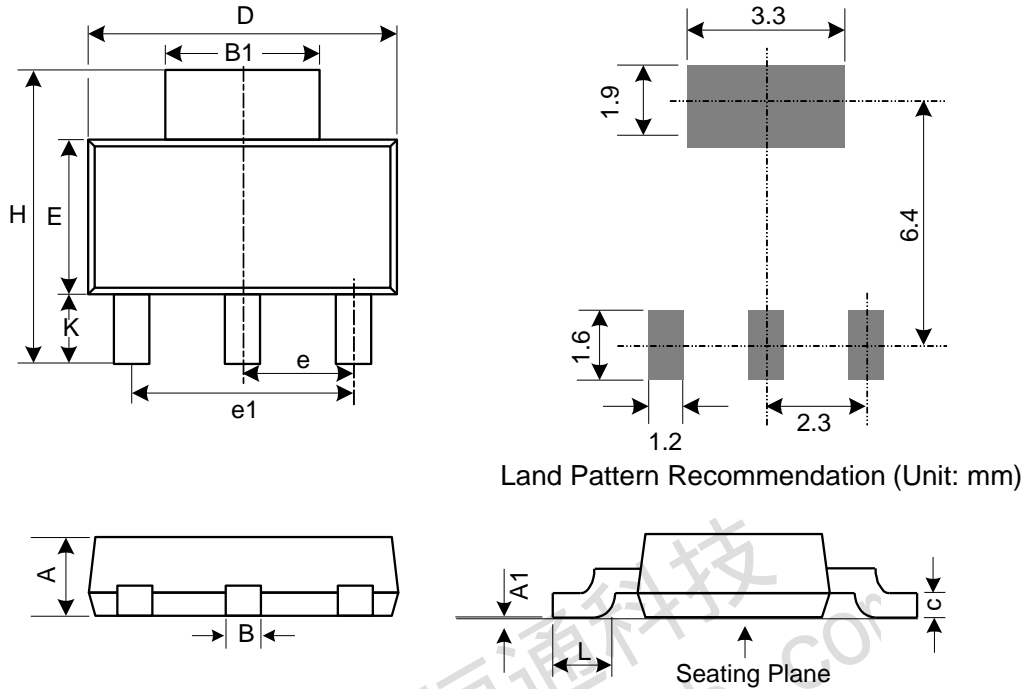
**❖ PACKAGE OUTLINES**
**(1) SOT223-3L**

Symbol	Dimensions in Millimeters			Dimensions in Inches		
	Min.	Nom.	Max.	Min.	Nom.	Max.
A	-	-	1.8	-	-	0.071
A1	0.02	0.06	0.1	0.001	0.002	0.004
B	0.66	0.75	0.84	0.026	0.03	0.033
B1	2.9	3	3.1	0.114	0.118	0.122
C	0.23	0.315	0.35	0.009	0.012	0.014
D	6.3	6.5	6.7	0.248	0.256	0.264
E	3.3	3.5	3.7	0.13	0.138	0.146
H	6.7	7	7.3	0.264	0.278	0.287
L	0.75	-	-	0.03	-	-
K	1.5	1.75	2	0.059	0.069	0.079
e	2.3 Basic			0.091 Basic		
e1	4.6 Basic			0.181 Basic		

JEDEC outline: TO-261 AB

(2) TO252-3L

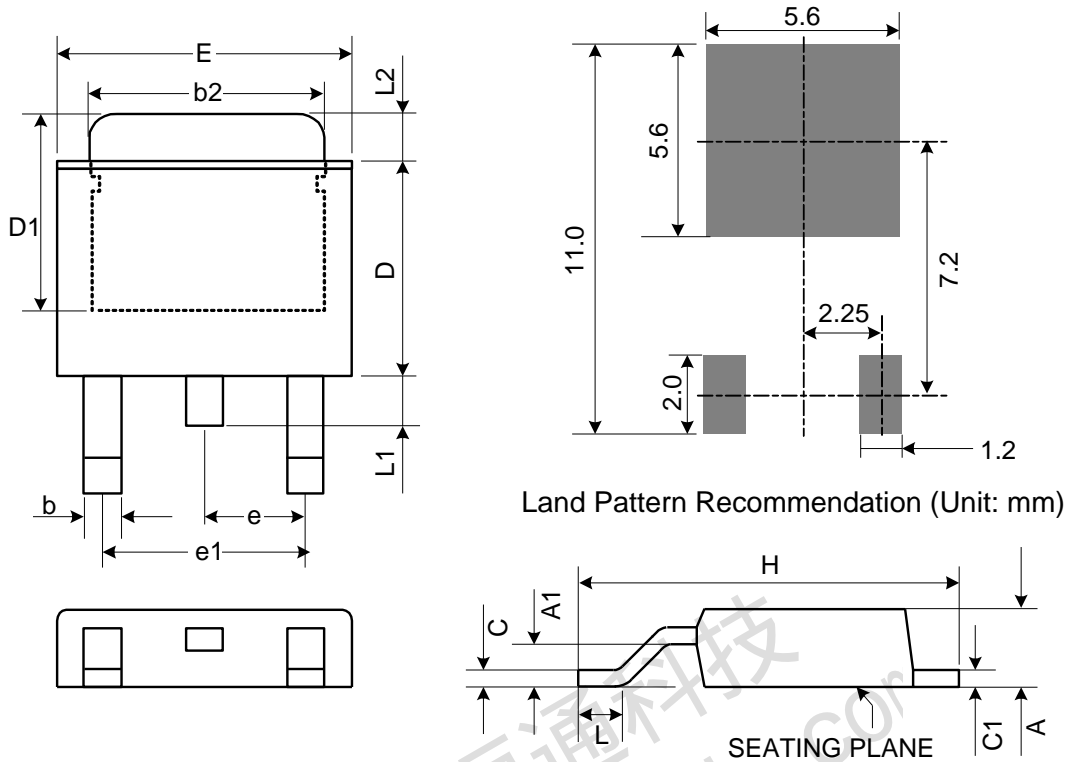

Symbol	Dimensions in Millimeters			Dimensions in Inches		
	Min.	Nom.	Max.	Min.	Nom.	Max.
A	2.18	2.29	2.39	0.086	0.09	0.094
A1	-	-	0.13	-	-	0.005
b	0.51	0.71	0.89	0.02	0.028	0.035
b2	4.95	5.21	5.46	0.195	0.205	0.215
C	0.46	0.53	0.61	0.018	0.021	0.024
C1	0.46	0.53	0.58	0.018	0.021	0.023
D	5.33	5.46	5.59	0.21	0.215	0.22
D1	4.57	-	-	0.18	-	-
E	6.35	6.55	6.73	0.25	0.258	0.265
e	2.29 BSC			0.090 BSC.		
e1	4.58 BSC			0.180 BSC.		
H	9.4	9.7	10.4	0.37	0.382	0.41
L	1.4	1.6	1.78	0.055	0.063	0.07
L1	-	-	1.02	-	-	0.04
L2	1.52	1.78	2.03	0.06	0.07	0.08

Mold flash shall not exceed 0.005inch per side  
JEDEC outline: TO-252 AB

(3) TO263-2L

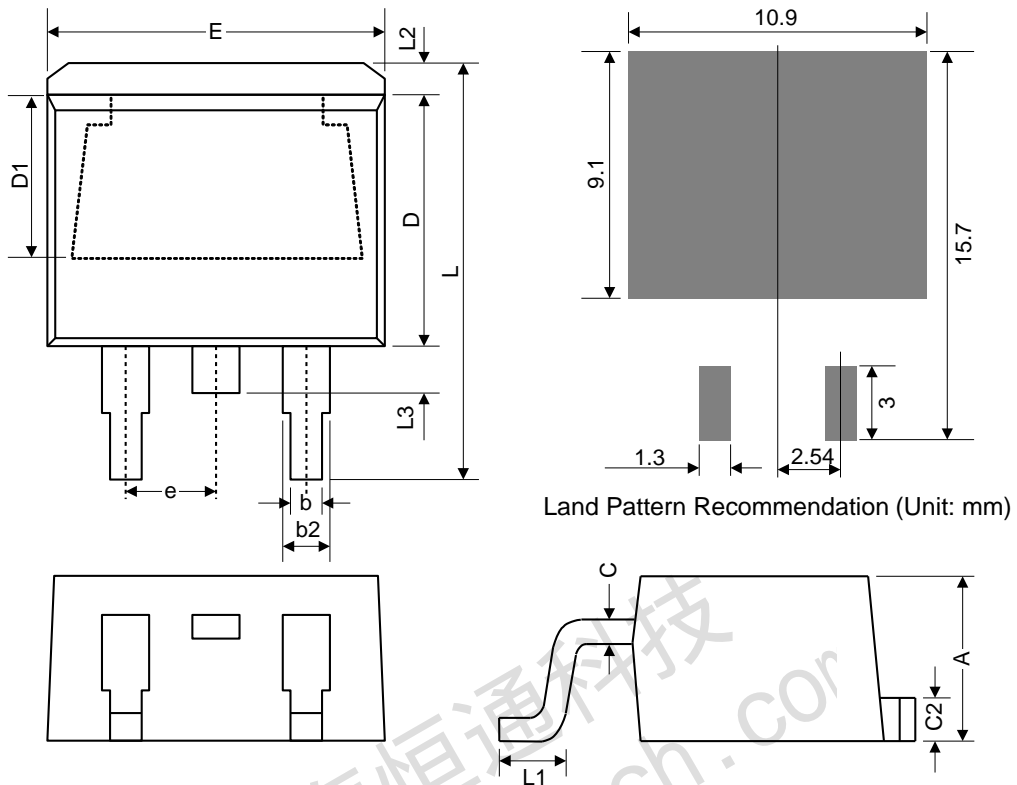

Symbol	Dimensions in Millimeters			Dimensions in Inches		
	Min.	Nom.	Max.	Min.	Nom.	Max.
A	4.06	4.45	4.83	0.16	0.175	0.19
b	0.51	0.76	0.99	0.02	0.03	0.039
b2	1.14	1.47	1.78	0.045	0.058	0.07
C	0.38	0.56	0.74	0.015	0.022	0.029
C2	1.14	1.4	1.65	0.045	0.055	0.065
D	8.38	9.02	9.65	0.33	0.355	0.38
D1	5.08	-	-	0.2	-	-
E	9.65	10.2	10.7	0.38	0.4	0.42
e	2.54 BSC			0.1 BSC		
L	14.6	15.2	15.9	0.575	0.6	0.625
L1	1.78	2.29	2.79	0.07	0.09	0.11
L2	-	-	1.68	-	-	0.066
L3	-	-	1.78	-	-	0.07

Mold flash shall not exceed 0.005inch per side  
JEDEC outline: TO-263 AB

(4) SOT89-3L

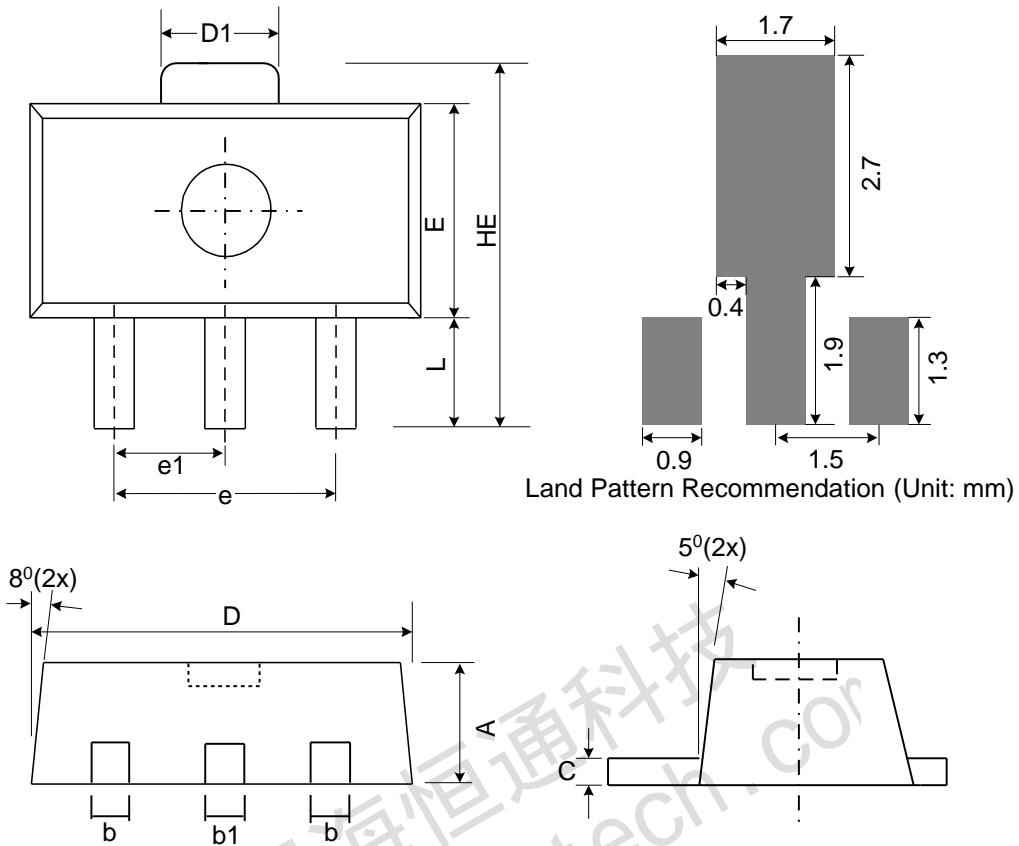

Symbol	Dimensions in Millimeters			Dimensions in Inches		
	Min.	Nom.	Max.	Min.	Nom.	Max.
A	1.40	1.50	1.60	0.055	0.059	0.063
b	0.36	0.42	0.48	0.014	0.017	0.019
b1	0.44	0.50	0.56	0.017	0.02	0.022
C	0.35	0.40	0.44	0.014	0.016	0.017
D	4.40	4.50	4.60	0.173	0.177	0.181
D1	1.35	1.59	1.83	0.053	0.063	0.072
e	3.0 BSC			0.118 BSC		
e1	1.5 BSC			0.059 BSC		
E	2.29	2.45	2.60	0.09	0.097	0.102
HE	3.94	4.10	4.25	0.155	0.161	0.167
L	0.80	1.00	1.20	0.031	0.04	0.047

JEDEC outline: TO-243 AB

(5) SOP8-8L

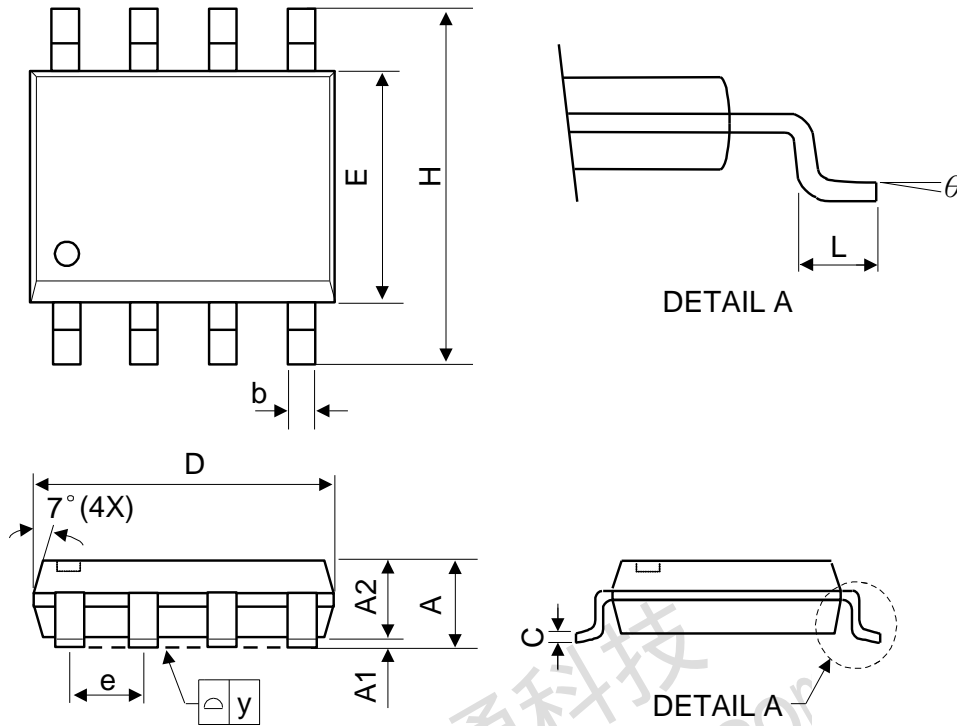

Symbol	Dimensions in Millimeters			Dimensions in Inches		
	Min.	Nom.	Max.	Min.	Nom.	Max.
A	-	-	1.75	-	-	0.069
A1	0.1	-	0.25	0.04	-	0.1
A2	1.25	-	-	0.049	-	-
C	0.1	0.2	0.25	0.0075	0.008	0.01
D	4.7	4.9	5.1	0.185	0.193	0.2
E	3.7	3.9	4.1	0.146	0.154	0.161
H	5.8	6	6.2	0.228	0.236	0.244
L	0.4	-	1.27	0.015	-	0.05
b	0.31	0.41	0.51	0.012	0.016	0.02
e	1.27 BSC			0.050 BSC		
y	-	-	0.1	-	-	0.004
$\theta$	0°	-	8°	0°	-	8°

Mold flash shall not exceed 0.25mm per side  
JEDEC outline: MS-012 AA