

TENTATIVE DATA
262,144 WORD x4 BIT DYNAMIC RAM

DESCRIPTION

The TC514256AP/AJ/AZ is the new generation dynamic RAM organized 262,144 words by 4 bits. The TC514256AP/AJ/AZ utilizes TOSHIBA's CMOS Silicon gate process technology as well as advanced circuit techniques to provide wide operating margins, both internally and to the system user. Multiplexed address inputs permit the TC514256AP/AJ/AZ to be packaged in a standard 20 pin plastic DIP, 26/20 pin plastic SOJ and 20/19 pin plastic ZIP. The package size provides high system bit densities and is compatible with widely available automated testing and insertion equipment. System oriented features include single power supply of $5V \pm 10\%$ tolerance, direct interfacing capability with high performance logic families such as Schottky TTL.

FEATURES

- 262,144 word by 4 bit organization
- Fast access time and cycle time

TC514256AP/AJ/AZ - 70/ - 80/ - 10				
t_{RAA}	RAS Access Time	70ns	80ns	100ns
t_{CAA}	Column Address Access Time	35ns	40ns	50ns
t_{CAC}	CAS Access Time	20ns	20ns	25ns
t_{RC}	Cycle Time	130ns	150ns	180ns
t_{PC}	Fast Page Mode Cycle Time	40ns	45ns	55ns

- Single power supply of $5V \pm 10\%$ with a built-in V_{RB} generator

- Low Power
 - 440mW MAX. Operating (TC514256AP/AJ/AZ-70)
 - 385mW MAX. Operating (TC514256AP/AJ/AZ-80)
 - 330mW MAX. Operating (TC514256AP/AJ/AZ-10)
 - 5.5mW MAX. Standby
- Outputs unlatched at cycle end allows two-dimensional chip selection
- Read-Modify-Write, CAS before RAS refresh, RAS-only refresh, Hidden refresh, and Fast Page Mode capability
- All inputs and outputs TTL compatible
- 512 refresh cycles/8ms
- Package
 - TC514256AP : DIP20-P-300B
 - TC514256AJ : SOJ26-P-300
 - TC514256AZ : ZIP20-P-400

PIN NAMES

A0~A8	Address Inputs	I/O1~I/O4	Data Input/Output
\overline{RAS}	Row Address Strobe	V_{CC}	Power (+5V)
\overline{CAS}	Column Address Strobe	V_{SS}	Ground
WRITE	Read/Write Input	N.C.	No Connection
\overline{OE}	Output Enable		

PIN CONNECTION (TOP VIEW)

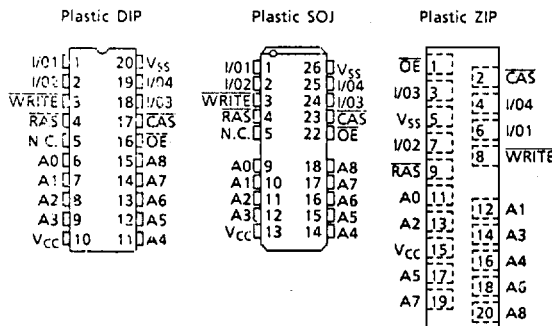

TC514256AP/AJ/AZ-70, TC514256AP/AJ/AZ-80 TC514256AP/AJ/AZ-10

BLOCK DIAGRAM

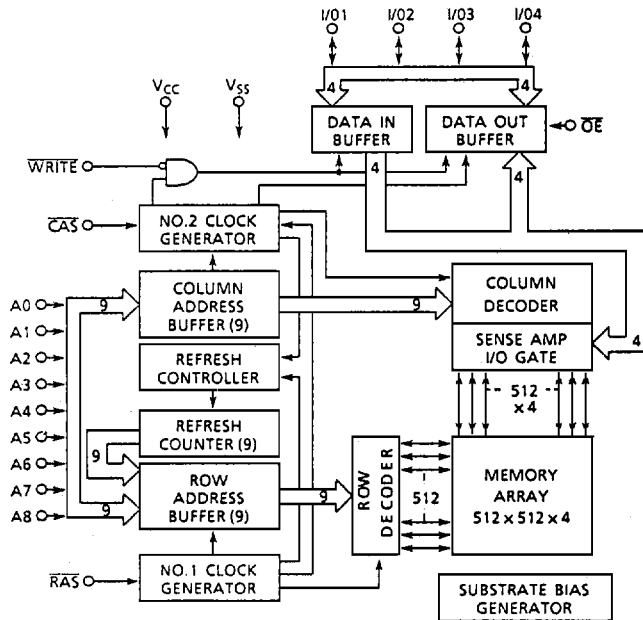

MAXIMUM RATINGS

CHARACTERISTIC	SYMBOL	RATING	UNIT	NOTE
Input Voltage	V_{IN}	-1~7	V	1
Output Voltage	V_{OUT}	-1~7	V	1
Power Supply Voltage	V_{CC}	-1~7	V	1
Operating Temperature	T_{OPR}	0~70	°C	1
Storage Temperature	T_{STG}	-55~150	°C	1
Soldering Temperature · Time	T_{SOLDER}	260 · 10	°C · sec	1
Power Dissipation	P_D	600	mW	1
Short Circuit Output Current	I_{OUT}	50	mA	1

RECOMMENDED DC OPERATING CONDITIONS ($T_a = 0 \sim 70^\circ\text{C}$)

SYMBOL	CHARACTERISTIC	MIN.	TYP.	MAX.	UNIT	NOTE
V_{CC}	Supply Voltage	4.5	5.0	5.5	V	2
V_{IH}	Input High Voltage	2.4	-	6.5	V	2
V_{IL}	Input Low Voltage	-1.0	-	0.8	V	2

TC514256AP/AJ/AZ-70, TC514256AP/AJ/AZ-80 TC514256AP/AJ/AZ-10

DC ELECTRICAL CHARACTERISTICS ($V_{CC} = 5V \pm 10\%$, $T_a = 0 \sim 70^\circ C$)

SYMBOL	CHARACTERISTIC	MIN.	MAX.	UNIT	NOTE	
I _{CC1}	OPERATING CURRENT Average Power Supply Operating Current (\overline{RAS} , \overline{CAS} , Address Cycling: $t_{RC} = t_{RC}$ MIN.)	TC514256AP/AJ/AZ-70	-	80	mA	3, 4, 5
		TC514256AP/AJ/AZ-80	-	70		
		TC514256AP/AJ/AZ-10	-	60		
I _{CC2}	STANDBY CURRENT Power Supply Standby Current ($\overline{RAS} = \overline{CAS} = V_{IH}$)	-	2	mA		
I _{CC3}	\overline{RAS} ONLY REFRESH CURRENT Average Power Supply Current, \overline{RAS} Only Mode (\overline{RAS} Cycling, $\overline{CAS} = V_{IH}$; $t_{RC} = t_{RC}$ MIN.)	TC514256AP/AJ/AZ-70	-	80	mA	3, 5
		TC514256AP/AJ/AZ-80	-	70		
		TC514256AP/AJ/AZ-10	-	60		
I _{CC4}	FAST PAGE MODE CURRENT Average Power Supply Current, Fast Page Mode ($\overline{RAS} = V_{IL}$, \overline{CAS} , Address Cycling: $t_{PC} = t_{PC}$ MIN.)	TC514256AP/AJ/AZ-70	-	60	mA	3, 4, 5
		TC514256AP/AJ/AZ-80	-	50		
		TC514256AP/AJ/AZ-10	-	40		
I _{CC5}	STANDBY CURRENT Power Supply Standby Current ($\overline{RAS} = \overline{CAS} = V_{CC} - 0.2V$)	-	1	mA		
I _{CC6}	\overline{CAS} BEFORE \overline{RAS} REFRESH CURRENT Average Power Supply Current, \overline{CAS} Before \overline{RAS} Mode (\overline{RAS} , \overline{CAS} Cycling: $t_{RC} = t_{RC}$ MIN.)	TC514256AP/AJ/AZ-70	-	80	mA	3
		TC514256AP/AJ/AZ-80	-	70		
		TC514256AP/AJ/AZ-10	-	60		
I _{I (L)}	INPUT LEAKAGE CURRENT Input Leakage Current, any input ($0V \leq V_{IN} \leq 6.5V$, All Other Pins Not Under Test = $0V$)	-10	10	μA		
I _{O (L)}	OUTPUT LEAKAGE CURRENT (D_{OUT} is disabled, $0V \leq V_{OUT} \leq 5.5V$)	-10	10	μA		
V _{OH}	OUTPUT LEVEL Output "H" Level Voltage ($I_{OUT} = -5mA$)	2.4	-	V		
V _{OL}	OUTPUT LEVEL Output "L" Level Voltage ($I_{OUT} = 4.2mA$)	-	0.4	V		

TC514256AP/AJ/AZ-70, TC514256AP/AJ/AZ-80 TC514256AP/AJ/AZ-10

ELECTRICAL CHARACTERISTICS AND RECOMMENDED AC OPERATING CONDITIONS

($V_{CC} = 5V \pm 10\%$, $T_a = 0 \sim 70^\circ\text{C}$) (Notes 6, 7, 8)

SYMBOL	CHARACTERISTIC	TC514256AP/ AJ/AZ-70		TC514256AP/ AJ/AZ-80		TC514256AP/ AJ/AZ-10		UNIT	NOTE
		MIN.	MAX.	MIN.	MAX.	MIN.	MAX.		
t_{RC}	Random Read or Write Cycle Time	130	-	150	-	180	-	ns	
t_{RMW}	Read-Modify-Write Cycle Time	185	-	205	-	245	-	ns	
t_{PC}	Fast Page Mode Cycle Time	40	-	45	-	55	-	ns	
t_{PRMW}	Fast Page Mode Read-Modify-Write Cycle Time	95	-	100	-	120	-	ns	
t_{RAC}	Access Time from \overline{RAS}	-	70	-	80	-	100	ns	9,14
t_{CAC}	Access Time from \overline{CAS}	-	20	-	20	-	25	ns	9,14
t_{AA}	Access Time from Column Address	-	35	-	40	-	50	ns	9,15
t_{CPA}	Access Time from \overline{CAS} Precharge	-	35	-	40	-	50	ns	9
t_{CLZ}	\overline{CAS} to output in Low-Z	0	-	0	-	0	-	ns	9
t_{OFF}	Output Buffer Turn-off Delay	0	20	0	20	0	20	ns	10
t_T	Transition Time (Rise and Fall)	3	50	3	50	3	50	ns	8
t_{RP}	\overline{RAS} Precharge Time	50	-	60	-	70	-	ns	
t_{RAS}	\overline{RAS} Pulse Width	70	10,000	80	10,000	100	10,000	ns	
t_{RASp}	\overline{RAS} Pulse Width (Fast Page Mode)	70	100,000	80	100,000	100	100,000	ns	
t_{RSH}	\overline{RAS} Hold Time	20	-	20	-	25	-	ns	
t_{RHCP}	\overline{RAS} Hold Time From \overline{CAS} Precharge (Fast Page Mode)	35	-	40	-	50	-	ns	
t_{CSH}	\overline{CAS} Hold Time	70	-	80	-	100	-	ns	
t_{CAS}	\overline{CAS} Pulse Width	20	10,000	20	10,000	25	10,000	ns	
t_{RCD}	\overline{RAS} to \overline{CAS} Delay Time	20	50	20	60	25	75	ns	14
t_{RAD}	\overline{RAS} to Column Address Delay Time	15	35	15	40	20	50	ns	15
t_{CRP}	\overline{CAS} to \overline{RAS} Precharge Time	5	-	5	-	5	-	ns	
t_{CP}	\overline{CAS} Precharge Time	10	-	10	-	10	-	ns	
t_{ASR}	Row Address Set-Up Time	0	-	0	-	0	-	ns	
t_{RAH}	Row Address Hold Time	10	-	10	-	15	-	ns	
t_{ASC}	Column Address Set-Up Time	0	-	0	-	0	-	ns	
t_{CAH}	Column Address Hold Time	15	-	15	-	20	-	ns	
t_{AR}	Column Address Hold Time referenced to \overline{RAS}	55	-	60	-	75	-	ns	
t_{RAL}	Column Address to \overline{RAS} Lead Time	35	-	40	-	50	-	ns	
t_{RCS}	Read Command Set-Up Time	0	-	0	-	0	-	ns	
t_{RCH}	Read Command Hold Time	0	-	0	-	0	-	ns	11
t_{RRH}	Read Command Hold Time referenced to \overline{RAS}	0	-	0	-	0	-	ns	11
t_{WCH}	Write Command Hold Time	15	-	15	-	20	-	ns	

TC514256AP/AJ/AZ-70, TC514256AP/AJ/AZ-80 TC514256AP/AJ/AZ-10

ELECTRICAL CHARACTERISTICS AND RECOMMENDED AC OPERATING CONDITIONS (Continued)

SYMBOL	CHARACTERISTIC	TC514256AP/ AJ/AZ-70		TC514256AP/ AJ/AZ-80		TC514256AP/ AJ/AZ-10		UNIT	NOTE
		MIN.	MAX.	MIN.	MAX.	MIN.	MAX.		
t _{WCR}	Write Command Hold Time referenced to \overline{RAS}	55	-	60	-	75	-	ns	
t _{WP}	Write Command Pulse Width	15	-	15	-	20	-	ns	
t _{RWL}	Write Command to \overline{RAS} Lead Time	20	-	20	-	25	-	ns	
t _{CWL}	Write Command to \overline{CAS} Lead Time	20	-	20	-	25	-	ns	
t _{DS}	Data Set-Up Time	0	-	0	-	0	-	ns	12
t _{DH}	Data Hold Time	15	-	15	-	20	-	ns	12
t _{DHR}	Data Hold Time referenced to \overline{RAS}	55	-	60	-	75	-	ns	
t _{REF}	Refresh Period	-	8	-	8	-	8	ms	
t _{WCS}	Write Command Set-Up Time	0	-	0	-	0	-	ns	13
t _{CWD}	\overline{CAS} to WRITE Delay Time	50	-	50	-	60	-	ns	13
t _{RWD}	\overline{RAS} to WRITE Delay Time	100	-	110	-	135	-	ns	13
t _{AWD}	Column Address to WRITE Delay Time	65	-	70	-	85	-	ns	13
t _{CPWD}	\overline{CAS} Precharge to WRITE Delay Time	65	-	70	-	85	-	ns	13
t _{CSR}	\overline{CAS} Set-Up Time (\overline{CAS} before \overline{RAS} Cycle)	5	-	5	-	5	-	ns	
t _{CHR}	\overline{CAS} Hold Time (\overline{CAS} before \overline{RAS} Cycle)	15	-	15	-	20	-	ns	
t _{RPC}	\overline{RAS} to \overline{CAS} Precharge Time	0	-	0	-	0	-	ns	
t _{CPT}	\overline{CAS} Precharge Time (\overline{CAS} before \overline{RAS} Counter Test Cycle)	40	-	40	-	50	-	ns	
t _{ROH}	\overline{RAS} Hold Time referenced to \overline{OE}	10	-	10	-	20	-	ns	
t _{DEA}	\overline{OE} Access Time	-	20	-	20	-	25	ns	
t _{OED}	\overline{OE} to Data Delay	20	-	20	-	25	-	ns	
t _{OEZ}	Output buffer turn off Delay Time from \overline{OE}	0	20	0	20	0	25	ns	10
t _{OEH}	\overline{OE} Command Hold Time	20	-	20	-	25	-	ns	

CAPACITANCE ($V_{CC} = 5V \pm 10\%$, $f = 1\text{MHz}$, $T_a = 0\sim 70^\circ\text{C}$)

SYMBOL	CHARACTERISTIC	MIN.	MAX.	UNIT
C ₁₁	Input Capacitance (A0~A8)	-	5	pF
C ₁₂	Input Capacitance (\overline{RAS} , \overline{CAS} , WRITE, \overline{OE})	-	7	pF
C ₀	Input/Output Capacitance (I/O1~I/O4)	-	7	pF

TC514256AP/AJ/AZ-70, TC514256AP/AJ/AZ-80 TC514256AP/AJ/AZ-10

NOTES:

1. Stresses greater than those listed under "Maximum Ratings" may cause permanent damage to the device.
2. All voltages are referenced to V_{SS} .
3. I_{CC1} , I_{CC3} , I_{CC4} depend on cycle rate.
4. I_{CC1} , I_{CC4} , I_{CC6} depend on output loading. Specified values are obtained with the output open.
5. Column address can be changed once or less while $\overline{RAS}=V_{IL}$ and $\overline{CAS}=V_{IH}$.
6. An initial pause of 200ps is required after power-up followed by 8 \overline{RAS} cycles before proper device operation is achieved. In case of using internal refresh counter, a minimum of 8 \overline{CAS} before \overline{RAS} initialization cycles instead of 8 \overline{RAS} cycles are required.
7. AC measurements assume $t_T=5ns$.
8. V_{IH} (min.) and V_{IL} (max.) are reference levels for measuring timing of input signals. Also, transition times are measured between V_{IH} and V_{IL} .
9. Measured with a load equivalent to 2 TTL loads and 100pF.
10. t_{OFF} (max.) and t_{OEZ} (max.) define the time at which the output achieves the open circuit condition and are not referenced to output voltage levels.
11. Either t_{RCH} or t_{RRH} must be satisfied for a read cycle.
12. These parameters are referenced to \overline{CAS} leading edge in early write cycles and to \overline{WRITE} leading edge in Read-Modify-Write cycles.
13. t_{WCS} , t_{RWD} , t_{CWD} , t_{AWD} and t_{CPWD} are not restrictive operating parameters. They are included in the data sheet as electrical characteristics only. If $t_{WCS} \geq t_{WCS}(\text{min.})$, the cycle is an early write cycle and the data out pin will remain open circuit (high impedance) through the entire cycle; If $t_{RWD} \geq t_{RWD}(\text{min.})$, $t_{CWD} \geq t_{CWD}(\text{min.})$, $t_{AWD} \geq t_{AWD}(\text{min.})$ and $t_{CPWD} \geq t_{CPWD}(\text{min.})$ (Fast Page Mode), the cycle is a Read-Modify-Write cycle and the data out will contain data read from the selected cell: If neither of the above sets of conditions is satisfied, the condition of the data out (at access time) is indeterminate.
14. Operation within the $t_{RCD}(\text{max.})$ limit insures that $t_{RAC}(\text{max.})$ can be met. $t_{RCD}(\text{max.})$ is specified as a reference point only: If t_{RCD} is greater than the specified $t_{RCD}(\text{max.})$ limit, then access time is controlled by t_{CAC} .
15. Operation within the $t_{RAD}(\text{max.})$ limit insures that $t_{RAC}(\text{max.})$ can be met. $t_{RAD}(\text{max.})$ is specified as a reference point only: If t_{RAD} is greater than the specified $t_{RAD}(\text{max.})$ limit, then access time is controlled by t_{AA} .

TC514256AP/AJ/AZ-70, TC514256AP/AJ/AZ-80 TC514256AP/AJ/AZ-10

READ CYCLE

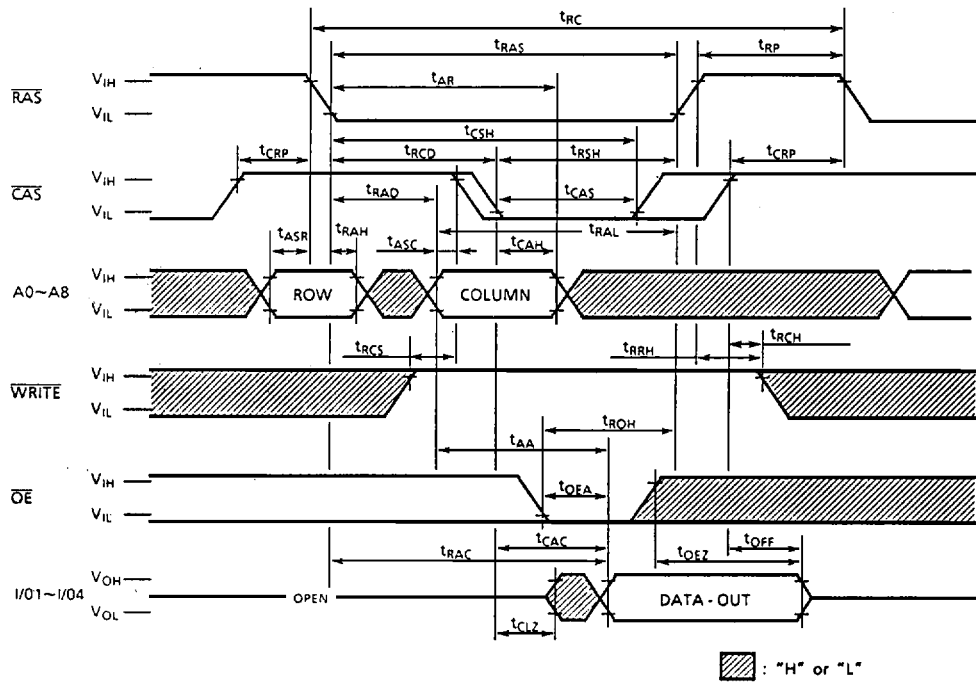

TC514256AP/AJ/AZ-70, TC514256AP/AJ/AZ-80
 TC514256AP/AJ/AZ-10

WRITE CYCLE (EARLY WRITE)

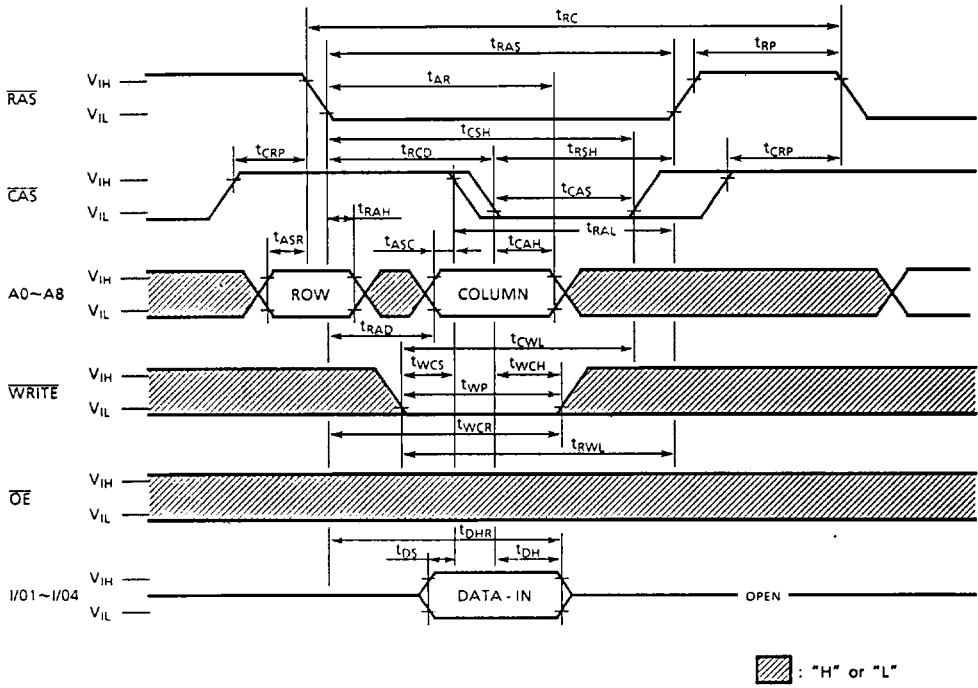

TC514256AP/AJ/AZ-70, TC514256AP/AJ/AZ-80 TC514256AP/AJ/AZ-10

WRITE CYCLE (\overline{OE} CONTROLLED WRITE)

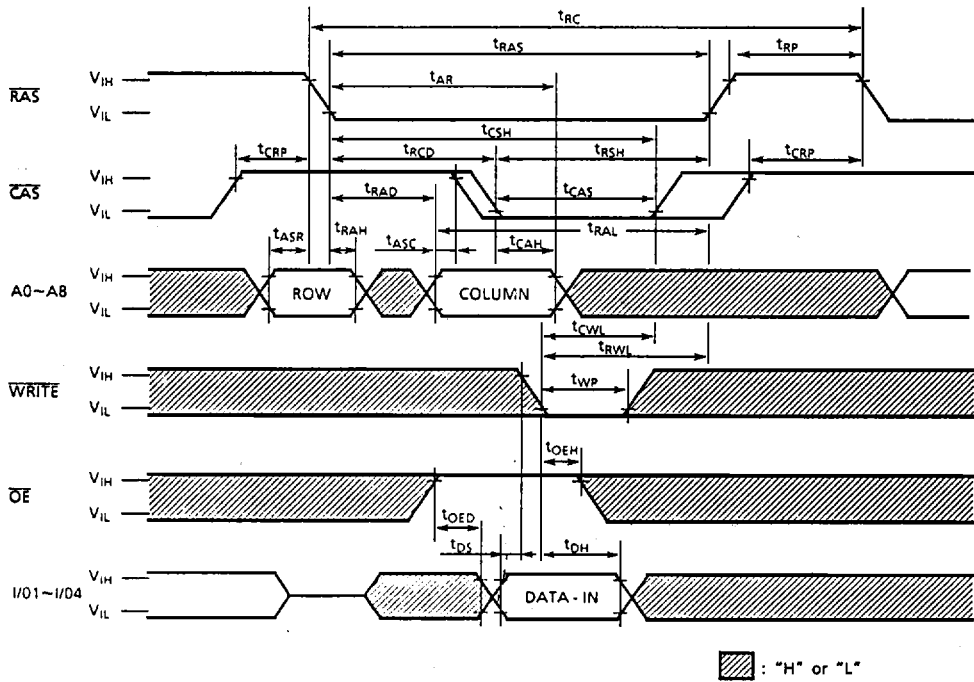

**TC514256AP/AJ/AZ-70, TC514256AP/AJ/AZ-80
TC514256AP/AJ/AZ-10**

READ-MODIFY-WRITE CYCLE

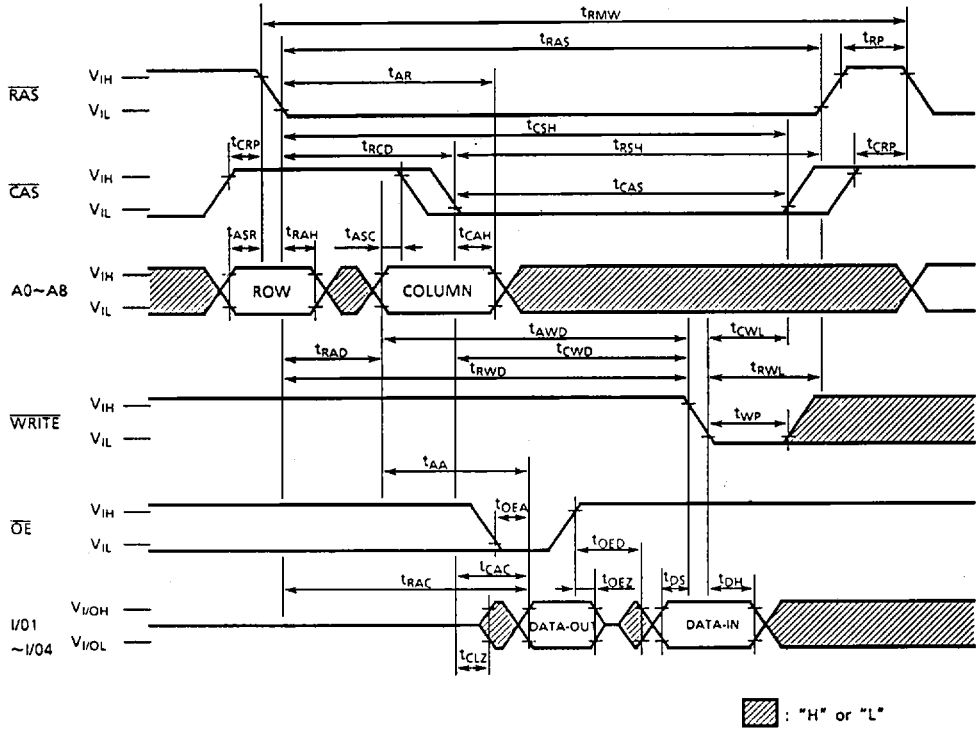

TC514256AP/AJ/AZ-70, TC514256AP/AJ/AZ-80
 TC514256AP/AJ/AZ-10

FAST PAGE MODE READ CYCLE

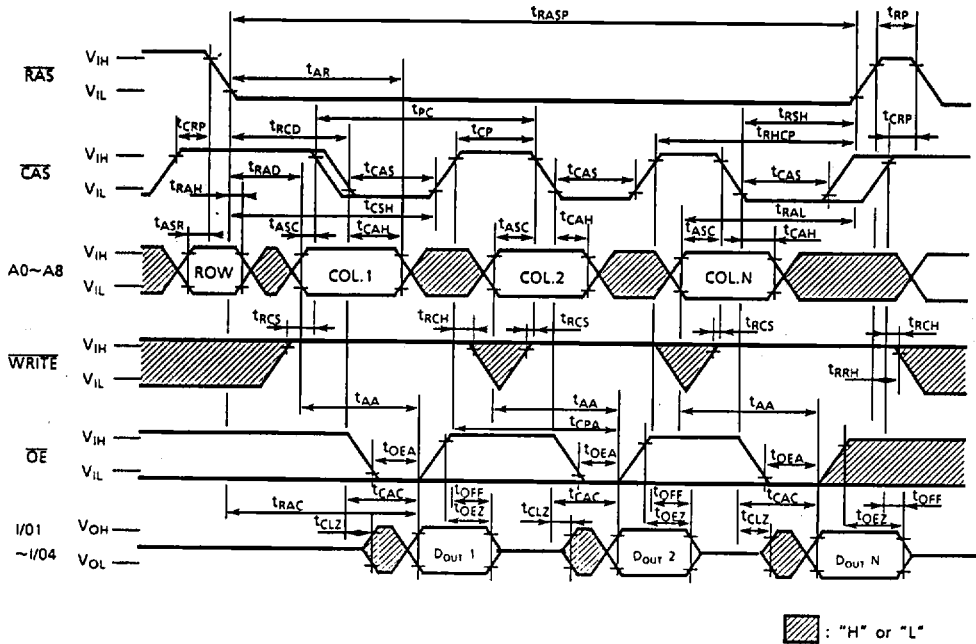

TC514256AP/AJ/AZ-70, TC514256AP/AJ/AZ-80
 TC514256AP/AJ/AZ-10

FAST PAGE MODE WRITE CYCLE

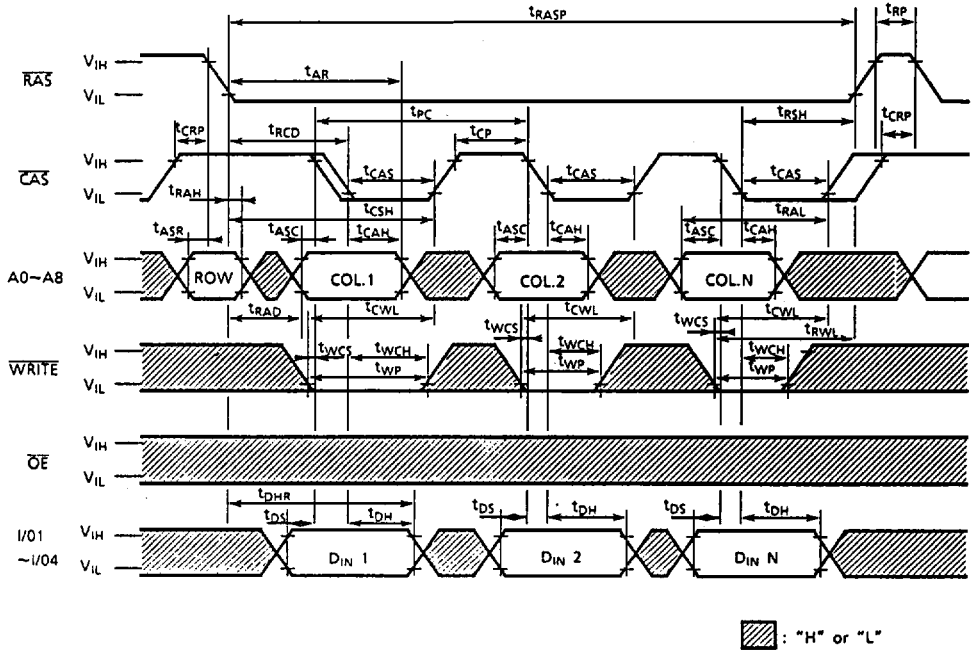

TC514256AP/AJ/AZ-70, TC514256AP/AJ/AZ-80
 TC514256AP/AJ/AZ-10

FAST PAGE MODE READ-MODIFY-WRITE CYCLE

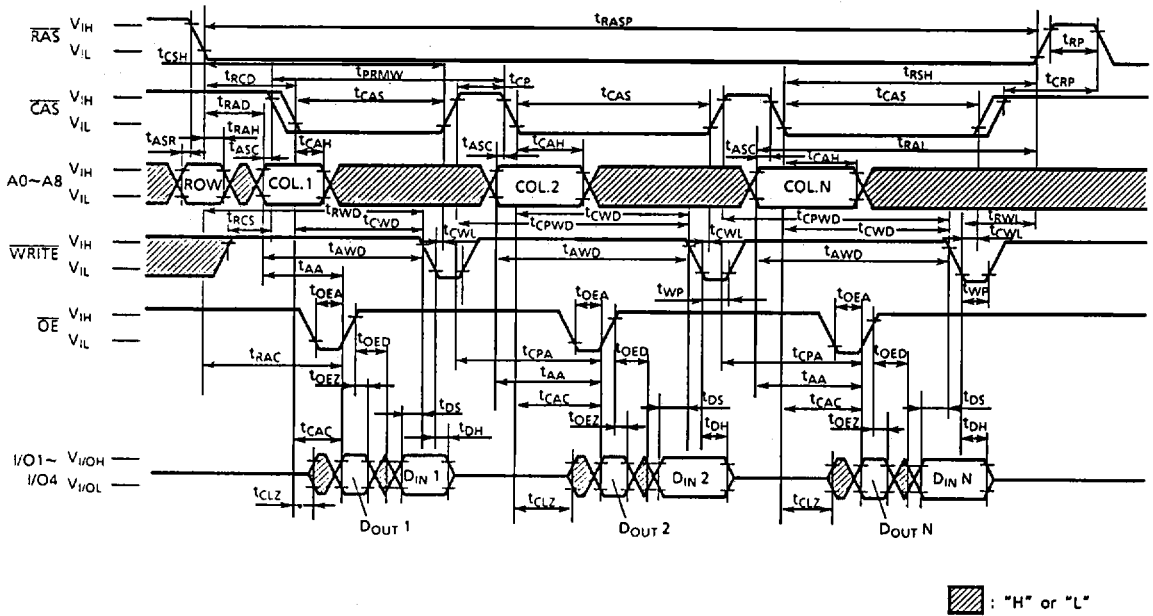

TC514256AP/AJ/AZ-70, TC514256AP/AJ/AZ-80
 TC514256AP/AJ/AZ-10

RAS ONLY REFRESH CYCLE

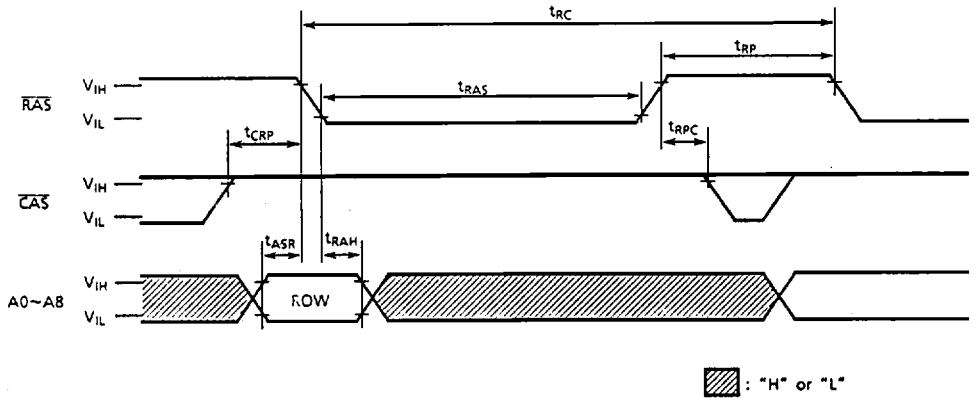

Note: WRITE, \overline{OE} = "H" or "L"

CAS BEFORE RAS REFRESH CYCLE

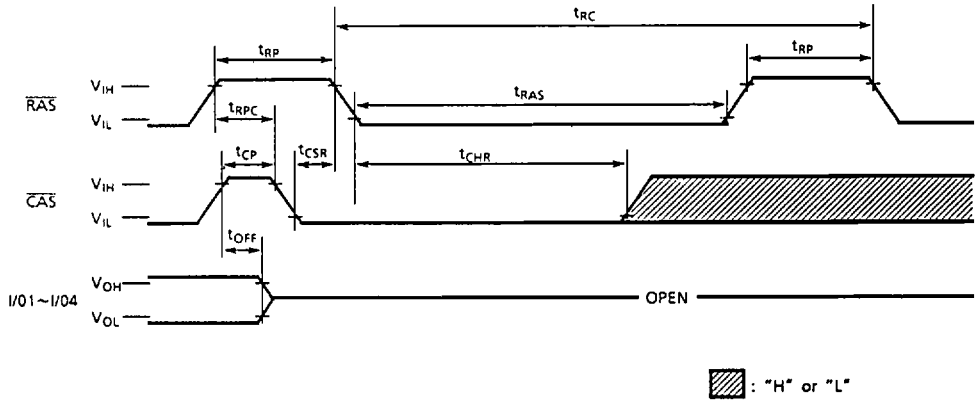

Note: WRITE, \overline{OE} = A0-A8 = "H" or "L"

TC514256AP/AJ/AZ-70, TC514256AP/AJ/AZ-80
 TC514256AP/AJ/AZ-10

HIDDEN REFRESH CYCLE (READ)

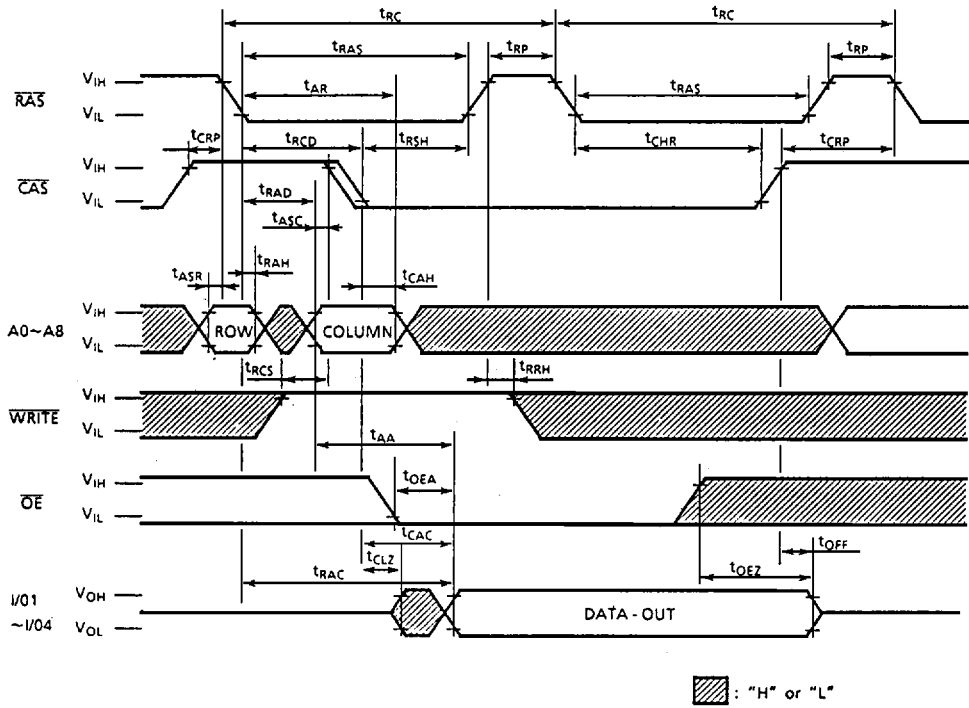

TC514256AP/AJ/AZ-70, TC514256AP/AJ/AZ-80
 TC514256AP/AJ/AZ-10

HIDDEN REFRESH CYCLE (WRITE)

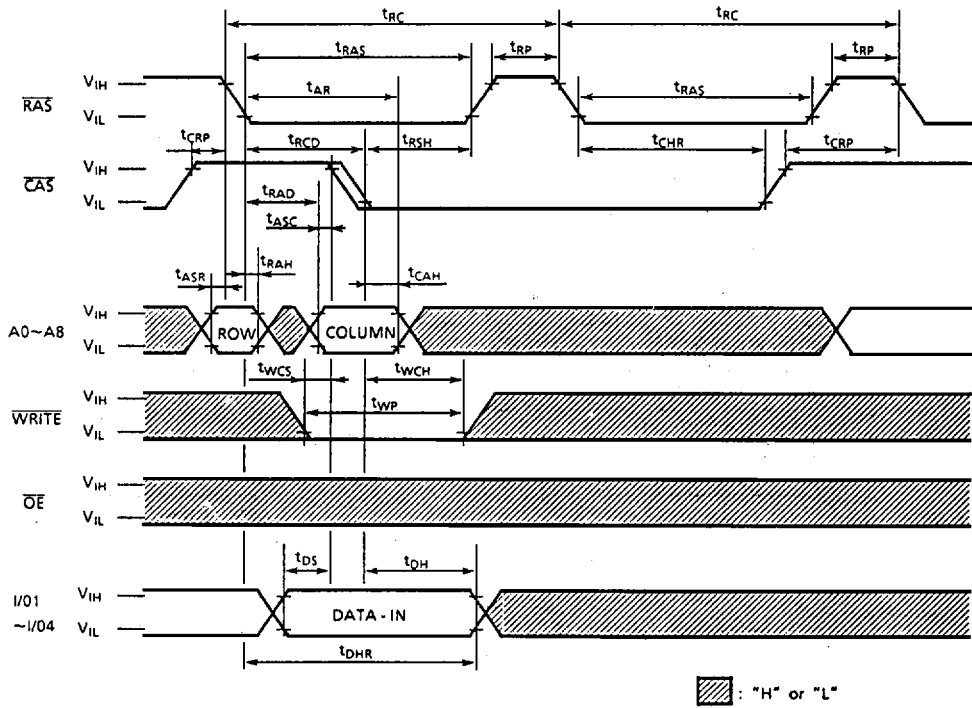

TC514256AP/AJ/AZ-70, TC514256AP/AJ/AZ-80 TC514256AP/AJ/AZ-10

CAS BEFORE RAS REFRESH COUNTER TEST CYCLE

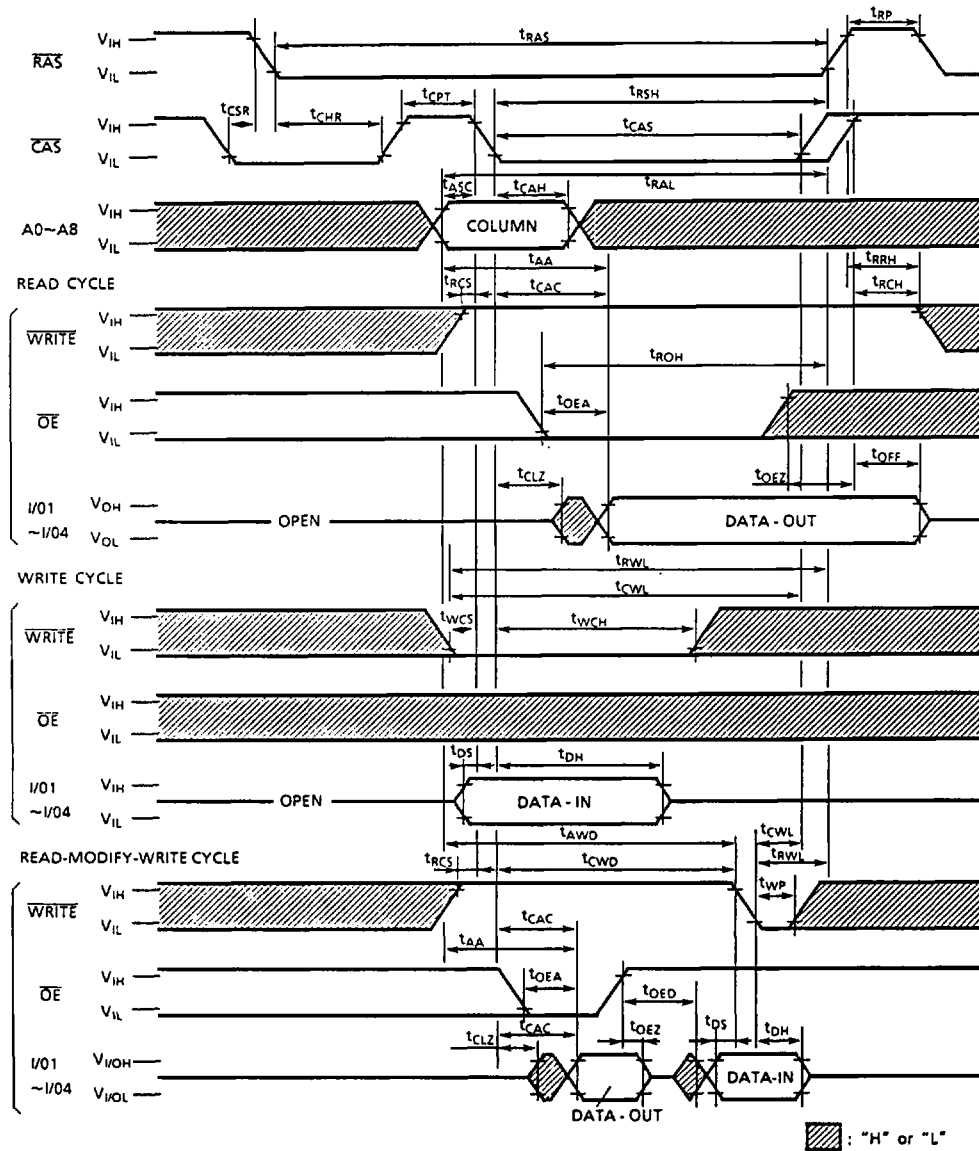

NOTES