



M.S.KENNEDY CORP.

**RADIATION HARDENED
HIGH EFFICIENCY, 4 AMP
SWITCHING REGULATORS**

**5046RH
SERIES**

4707 Dey Road Liverpool, N.Y. 13088

(315) 701-6751

FEATURES:

- Up To 92% Conversion Efficiency For 5V Version
- 4 Amp Output Current
- 3.1V to 18V Input Range with Startup Bias
- 12V to 18V Input Range with UVLO (VBias = VIN)
- Preset 1.5V, 2.5V, 3.0V, 3.3V or 5.0V Output Versions
- Custom Output Voltages Available
- 300KHz Switching Frequency
- Hermetic Package with Three Lead Form Options
- -55°C to +125°C Operating Temperature Range
- Total Dose Rated to TBDK RAD

MIL-PRF-38534 CERTIFIED

DESCRIPTION:

The MSK 5046RH series are high efficiency, 4 amp, radiation hardened switching regulators. The output voltage is configured for 1.5V, 2.5V, 3.0V, 3.3V or 5.0V internally with a tolerance of 1% at 1.5 amps. The operating frequency of the MSK 5046RH is 300KHz. A low quiescent current and greater than TBD operating efficiency keep the total internal power dissipation of the MSK 5046RH down to an absolute minimum. The device is packaged in a hermetic power package for high reliability applications, and is available fully compliant to MIL-PRF-38534 Class H or K.

EQUIVALENT SCHEMATIC

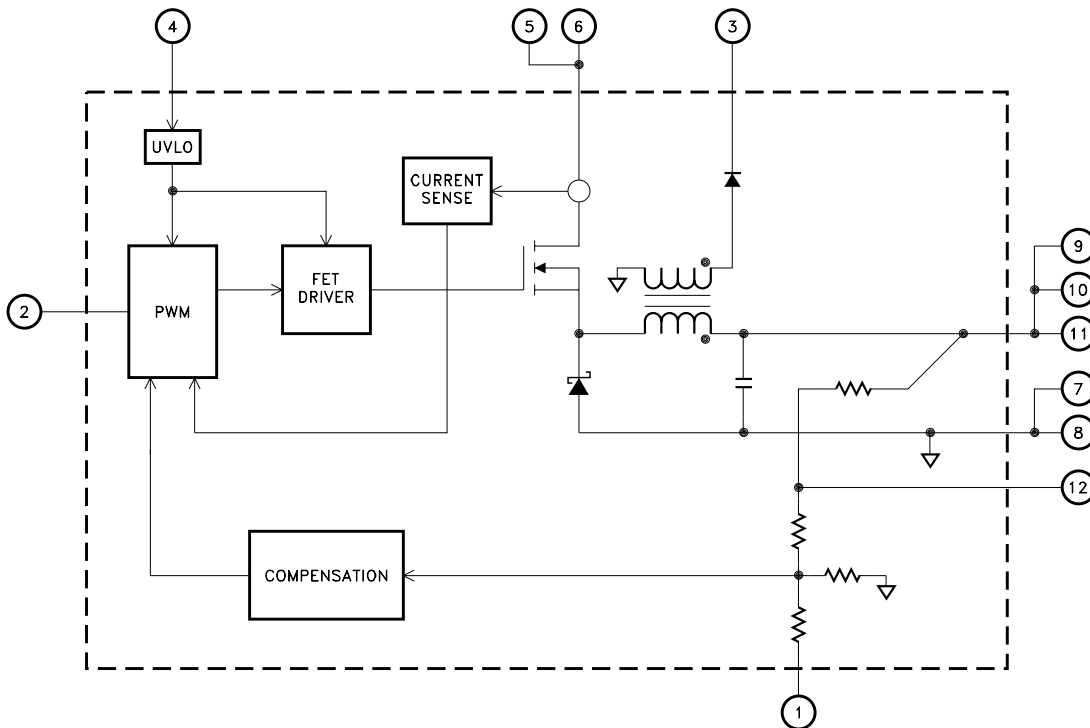

TYPICAL APPLICATIONS

- Step-down Switching Regulator
- Microprocessor, FPGA Power Source
- High Efficiency Low Voltage Subsystem Power Supply

PIN-OUT INFORMATION

1 COMP	12 SENSE
2 ENABLE	11 VOUT
3 VBOOT	10 VOUT
4 VBIAS	9 VOUT
5 VIN	8 RETURN
6 VIN	7 RETURN

ABSOLUTE MAXIMUM RATINGS

Input Voltage -0.3V, +20V
 Enable -0.3V, 10.5V
 Output Current 4.0 Amps
 Thermal Resistance (@ 125°C) 10°C/W

T_{ST} Storage Temperature Range -65°C to +150°C
 T_{LD} Lead Temperature Range 300°C
 (10 Seconds)
 T_C Case Operating Temperature
 MSK5046RH Series -40°C to +85°C
 MSK5046RH K/H/E Series -55°C to +125°C
 T_J Junction Temperature +150°C

ELECTRICAL SPECIFICATIONS

Parameter	Test Conditions ① ⑫	Group A Subgroup	MSK 5046RH K/H/E			MSK 5046RH			Units	
			Min.	Typ.	Max.	Min.	Typ.	Max.		
V _{IN} Input Supply Range ⑪ ⑩		1,2,3	Note 10	-	18	Note 10	-	18	V	
V _{Bias} Input Supply Range ②		1,2,3	12	-	18	12	-	18	V	
I _{Bias}	I _{OUT} = 1.5A	1	-	40	70	-	40	70	mA	
		2,3	-	40	80	-	40	80	mA	
Under Voltage Lockout	V _{Bias}	1	8.4	-	12.0	8.4	-	12.0	V	
Output Voltage 5046RH-1.5 ⑧ ⑨	I _{OUT} = 1.5A	1	1.48	1.50	1.52	1.46	1.50	1.54	V	
		2,3	1.42	1.50	1.58	-	-	-	V	
		V _{Boot}	1	-	14.5	-	-	14.5	-	V
Output Voltage 5046RH-2.5 ⑧ ⑨	I _{OUT} = 1.5A	1	2.47	2.5	2.55	2.42	2.5	2.58	V	
		2,3	2.38	2.5	2.63	-	-	-	V	
		V _{Boot}	1	-	14.3	-	-	14.3	-	V
Output Voltage 5046RH-3.0 ⑧ ⑨	I _{OUT} = 1.5A	1	2.97	3.0	3.03	2.94	3.0	3.06	V	
		2,3	2.85	-	3.15	-	-	-	V	
		V _{Boot}	1	-	14.4	-	-	14.4	-	V
Output Voltage 5046RH-3.3 ⑧ ⑨	I _{OUT} = 1.5A	1	3.27	3.3	3.33	3.23	3.3	3.37	V	
		2,3	3.14	3.3	3.47	-	-	-	V	
		V _{Boot}	1	-	14.4	-	-	14.4	-	V
Output Voltage 5046RH-5.0 ⑧ ⑨	I _{OUT} = 1.5A	1	4.95	5.0	5.05	4.9	5.0	5.1	V	
		2,3	4.75	5.0	5.25	-	-	-	V	
		V _{Boot}	1	-	14.7	-	-	14.7	-	V
Output Current ②	Within SOA	1	4.0	4.2	-	4.0	4.2	-	A	
Load Regulation	0.75A < I _{OUT} < 2.5A	1	-	±0.5	±1.0	-	±0.5	±1.5	%	
		2,3	-	±0.5	±1.5	-	-	-	%	
Line Regulation	I _{OUT} = 1.5A V _{Bias} = 12V V _{IN} Step = 6V to 12V	1	-	±0.5	±1.0	-	±0.5	±1.5	%	
		2,3	-	±0.5	±1.5	-	-	-	%	
Oscillator Frequency	I _{OUT} > 1.5A	4	270	300	330	270	300	330	KHz	
Enable Input Voltage ②	Open Circuit Voltage	1,2,3	3.1	4.9	5.28	3.1	4.9	5.28	V	
	Logic Low Disabled	1,2,3	-	-	0.8	-	-	0.8	V	
Enable Input Current ②	V _{EN} = 0V	1	-	480	600	-	480	600	µA	
Disabled Quiescent Current	V _{EN} = 0V	1,2,3	-	16	42	-	16	42	mA	
Efficiency ⑬	5046-1.5RH	V _{IN} = 3.3V I _{OUT} = 2.0A	-	TBD	70	-	TBD	70	-	%
	5046-2.5RH	V _{IN} = 5.0V I _{OUT} = 2.0A	-	TBD	80	-	TBD	80	-	%
	5046-3.0RH	V _{IN} = 5.0V I _{OUT} = 2.0A	-	TBD	80	-	TBD	80	-	%
	5046-3.3RH	V _{IN} = 5.0V I _{OUT} = 2.0A	-	TBD	85	-	TBD	85	-	%
	5046-5.0RH	V _{IN} = 7.0V I _{OUT} = 2.0A	-	TBD	89	-	TBD	89	-	%

NOTES:

- ① V_{IN} = 12V, V_{Bias} = 12V, I_{OUT} = 1.5A unless otherwise specified.
- ② Guaranteed by design but not tested. Typical parameters are representative of actual device performance but are for reference only.
- ③ All output parameters are tested using a low duty cycle pulse to maintain T_J = T_C.
- ④ Industrial grade and 'E' suffix devices shall be tested to subgroup 1 unless otherwise specified.
- ⑤ Military grade devices ('H' and 'K' suffix) shall be 100% tested to subgroups 1,2,3 and 4.
- ⑥ Subgroup 1
Subgroup 2
Subgroup 3 T_A = T_C = +25°C
- ⑧ Alternate output voltages are available. Please contact the factory.
- ⑨ V_{Boot} is measured with 540mA load on the V_{Boot} pin.
- ⑩ The device can operate with input voltages as high as 18V, but efficiency is best at lower inputs.
- ⑪ With V_{Bias} connected to a separate source, V_{IN} Min. is approximately 3.1V.
- ⑫ Contact factory for post radiation limits.
- ⑬ Includes V_{Bias} power consumption.

APPLICATION NOTES

INPUT BIAS AND UVLO:

The V_{Bias} pin of the MSK 5046RH provides bias to the control circuitry. The V_{bias} pin can be connected directly to the input bus for 12V to 16V operation or it can be biased separately with a 12V to 16V source to extend the input range of the device refer to the paragraph titled "INPUT VOLTAGE RANGE". The MSK 5046RH's built in under voltage lockout feature prevents damage to downstream devices in the event of a drop in bias voltage. Under voltage lockout occurs at bias voltages of approximately 10.3V rising and 9.5V falling. The internal bias draws approximately 40mA under normal operation.

INPUT VOLTAGE RANGE

The MSK 5046RH's input range of 12V to 16V can be further extended down to 3.1V by using a separate bias supply. In this configuration very efficient low V to low V conversion can be achieved.

BOOTSTRAPPING:

The MSK 5046RH's V_{boot} output can be used to supply bias voltage once the device is operating. Use a diode to "OR" the startup bias supply with the V_{boot} output if the startup supply voltage is less than V_{boot}. Use a switching scheme if V_{boot} is less than or equal to V_{startup}. Additional bypass capacitance is required on the V_{bias} input pin when bootstrapping the MSK 5046RH. Since the bootstrap voltage is stepped up from the output voltage, it will vary with load. Any voltage drop between the output and the sense pin will increase the bootstrap voltage. Direct biasing of the V_{Bias} input may be more efficient due to the additional conversion involved in bootstrapping.

INPUT CAPACITOR SELECTION:

The MSK 5046RH should have an external high frequency ceramic capacitor (0.1 μ F) between VIN and GND. Connect a low-ESR bulk capacitor directly to the input pin of the MSK 5046RH. Select the bulk input filter capacitor according to input ripple-current requirements and voltage rating, rather than capacitor value. Electrolytic capacitors that have low enough ESR to meet the ripple-current requirement invariably have more than adequate capacitance values. Aluminum-electrolytic capacitors are preferred over tantalum types, which could cause power-up surge-current failure when connecting to robust AC adapters or low-impedance batteries.

OUTPUT CAPACITOR SELECTION:

The MSK 5046RH has an internal 0.1 μ F ceramic capacitor between V_{OUT} and RETURN. An additional 1 μ F of ceramic capacitance on the output will help suppress the high frequency switching noise. Use between 100 and 300 μ F of low ESR bulk capacitance for optimum performance. Larger output capacitance may require additional loop compensation, refer to the paragraph titled "Compensation".

SENSE:

It is very important that the DC voltage returned to the SENSE pin from the output be as noise and oscillation free as possible. This voltage helps to determine the final output and therefore must be a clean voltage. Excessive noise or oscillation can cause the device to have an incorrect output voltage. Proper PC board layout techniques can help to achieve a noise free voltage at the SENSE pin.

ENABLE FUNCTION:

The ENABLE pin of the MSK 5046RH is designed for open collector drive. Leaving the pin open will allow for normal operation. Pulling the pin low will shut the device down.

COMPENSATION:

When driving large capacitive loads it may be necessary to connect a 10 to 20nF ceramic capacitor between the V_{SENSE} pin and the COMP pin. This will add a zero/pole pair to the overall loop transfer function to prevent oscillation and improve bandwidth.

TYPICAL BOOTSTRAPPED APPLICATION

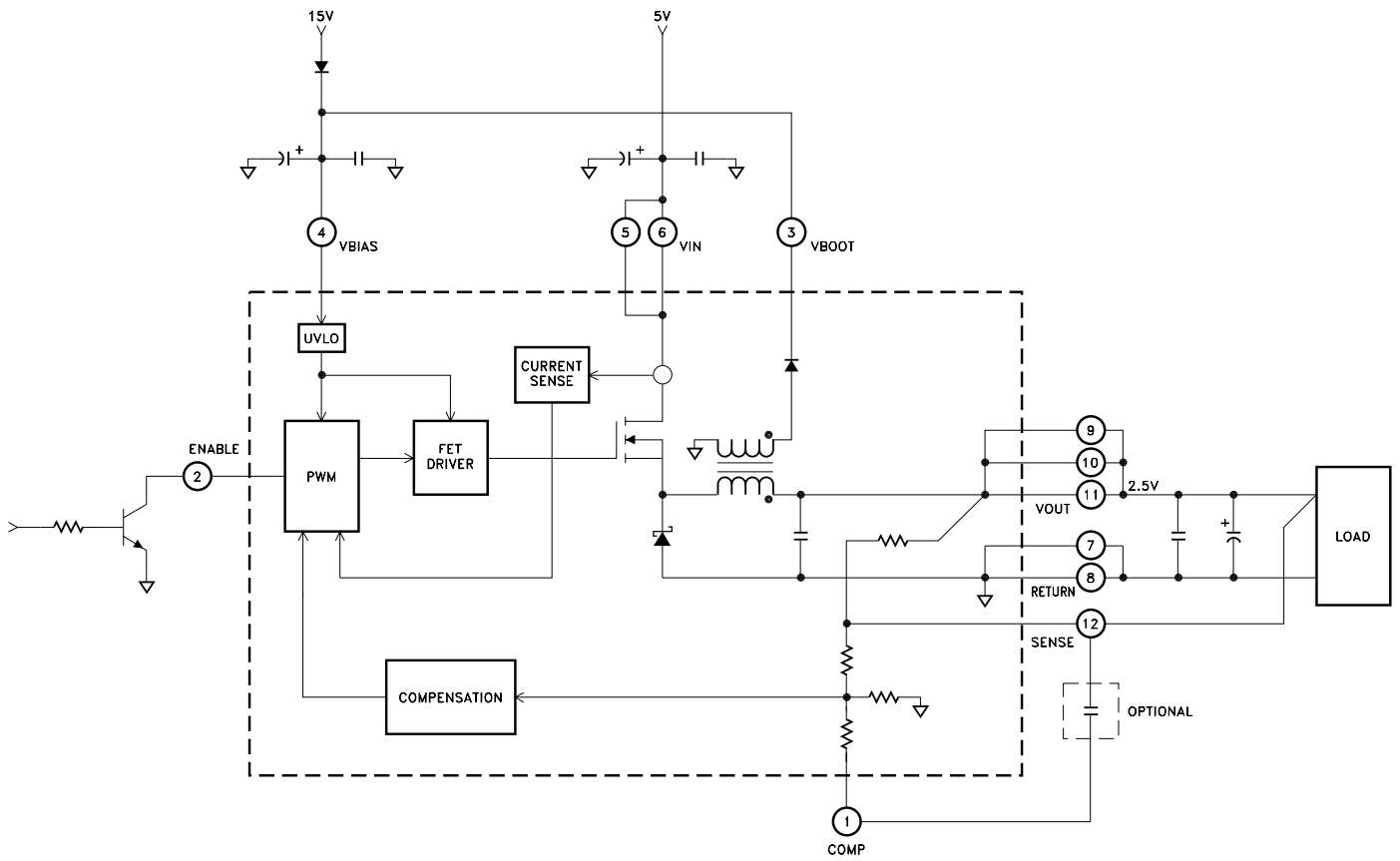

TYPICAL PERFORMANCE CURVES

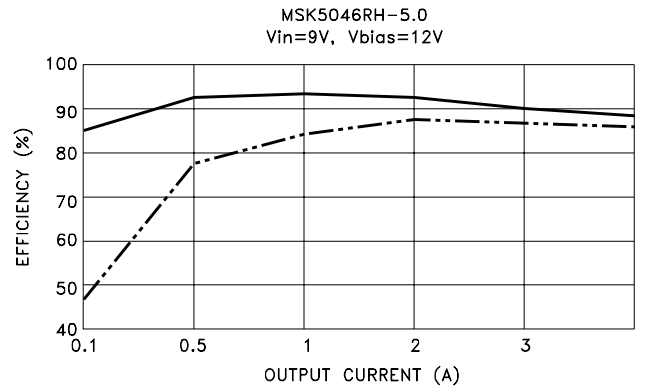
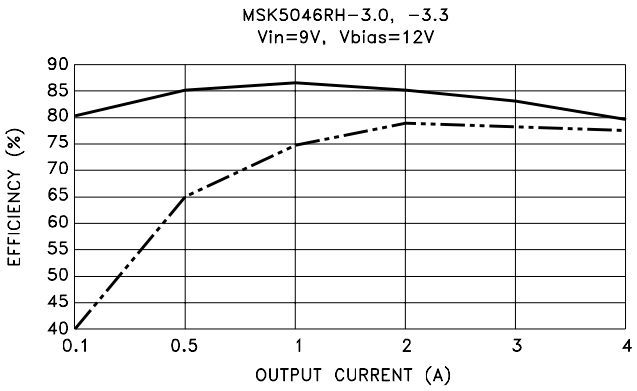
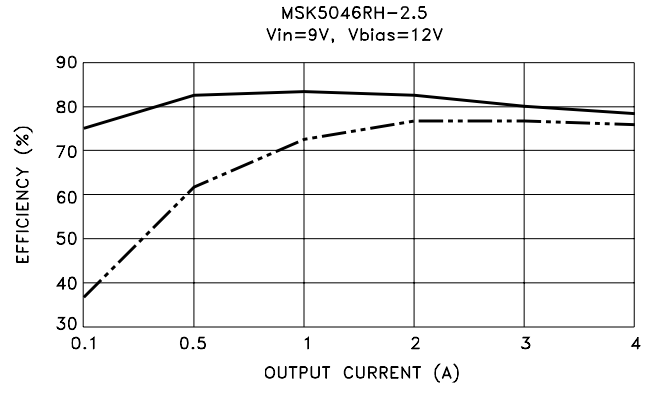
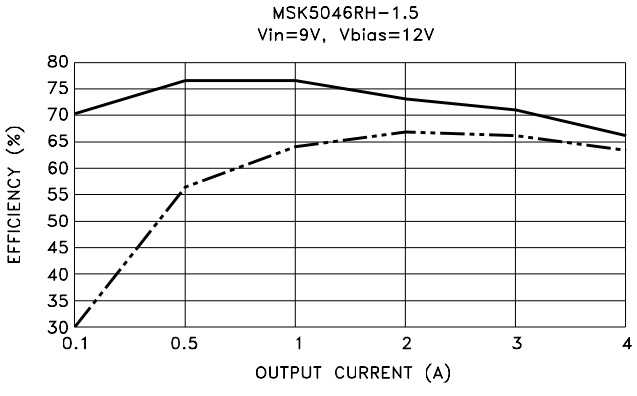

NOTE: Overall efficiency curves include VBias power consumption.

