



C488-Type 2.5 Gbits/s Tunable, Stabilized, Long-Haul Laser Transmitters



Offering multiple output power options and SONET/SDH compatibility, the C488-Type Tunable Laser Transmitters support four wavelengths and can be remotely programmed.

Features

- Data rates to 2.5 Gbits/s
- Long-haul transmission to 640 km
- SONET and ITU-T compliant at OC-48 and STM-16
- Integrated Fabry-Perot Etalon stabilizer
— Replaces external wavelength lockers
- Wavelength range, 1528.77 nm—1563.86 nm
- Optical output power adjustment (± 0.5 dB)
- Extinction ratio ≥ 11 dB
- Wavelength remotely programmable over four 50 GHz ITU-T channels
- Asynchronous serial interface for transmitter communication
- Dither signal input
- Clocked or nonclocked operation with single-ended or differential inputs
- 50 Ω ac-coupled PECL compatible data and clock inputs

- Low-profile, 24-pin package
- Laser bias monitor alarm
- Laser back-facet monitor output
- Transmitter-enable input

Applications

- SONET/SDH extended-reach
- Extra long-haul, very dense, wave-division multiplexing (DWDM)
- High-speed data communication
- Digitized video

Description

The C488-Type 2.5 Gbits/s Laser Transmitters are designed for use in transmission systems and high-speed data communication applications. The transmitter operates at the SONET OC-48 rate as well as the ITU-T SDH rate of STM-16. The device supports four wavelengths and uses an RS-232 interface to control various transmitter functions, including average optical power, wavelength, and fine-power. In addition, the interface allows access to the alarm and monitoring outputs as well as the unit's serial number.

The transmitters meet all present *Telcordia Technologies** GR-253-CORE requirements and the ITU-T G.957 and G.958 recommendations. They are also ideally suited for extended-distance data and networking applications.

The C488 Transmitter features a 1.5 μm laser with an electroabsorptive modulator and an integrated stabilizer. The device is capable of 360 km or 640 km transmission at 2.5 Gbits/s in DWDM systems at a channel spacing of 50 GHz or less. By integrating the modulator with the laser chip, the device offers a compact, cost-effective solution for extended-reach transmissions.

* *Telcordia Technologies* is a trademark of Bell Communications Research, Inc.

Description (continued)

The versatile C488-Type transmitters are available at wavelengths compatible with the ITU-T wavelength standards at 200 GHz, 100 GHz, and 50 GHz. The package also contains a thermoelectric cooler (TEC), thermistor, back-facet monitor, and optical isolator. The laser transmitter requires 5 V and -5.2 V power supplies; the TEC operates on 3.3 V. The clock can be enabled for those applications where jitter is critical.

Pin information is listed in Table 1.

Transmitter Processing

The transmitter can withstand normal wave soldering processes. The complete transmitter module is not hermetically sealed; therefore, it should not be immersed in or sprayed with any cleaning solution or solvents. The process cap and fiber pigtail jacket can deform at temperatures greater than 85 °C. The transmitter pins can be wave-soldered at a maximum temperature of 250 °C for 10 seconds.

Installation Considerations

Although the transmitter has been designed with ruggedness in mind, care should be used during handling. The optical connector should be kept free from dust, and the process cap should be kept in place as a dust cover when the device is not connected to a cable. If contamination is present on the optical connector, the use of canned air with an extension tube should remove any debris. Other cleaning procedures are identified in the *Cleaning Fiber-Optic Assemblies* Technical Note (TN95-010LWP).

Connector Options

The standard fiber-optic pigtail is an 8 µm core single-mode fiber in a 0.036 in. (914 µm) diameter, tight-buffered outer jacket. The standard length is 39 in. ± 4 in. (1 m ± 10 cm) and is terminated with an optical connector.

Table 1. Pin Descriptions

Pin Number	Name
1	Ground (TEC)
2	Back-facet Monitor *
3	Bias Monitor/Laser Degrade Alarm*
4	Tx Enable
5	Clock Select
6	Ground
7	Wavelength-Deviation Error Alarm
8	RS-232 Interface (Tx)
9	RS-232 Interface (Rx)
10	Dither Input
11	Ground
12	VEE
13	Vcc
14	VTEC (TEC supply voltage)
15	Ground
16	DATA
17	Ground
18	DATA
19	Ground
20	CLOCK
21	Ground
22	CLOCK
23	Ground
24	Vcc

* Laser back-facet and bias alarm functions are customer-use options that are not required for normal operations of the transmitter and are normally used during manufacture and for diagnostics. The output will optionally be either a logic signal or an analog voltage. All alarm, select, and enable signals are active-high.

Absolute Maximum Ratings

Stresses in excess of the absolute maximum ratings can cause permanent damage to the device. These are absolute stress ratings only. Functional operation of the device is not implied at these or any other conditions in excess of those given in the operations sections of the data sheet. Exposure to absolute maximum ratings for extended periods can adversely affect device reliability.

Parameter	Symbol	Min	Max	Unit
Supply Voltage (positive)	V _{CC}	—	5.25	V
Supply Voltage (negative)	V _{EE}	—	-6.0	V
Operating Case Temperature Range	T _C	0	70	°C
Storage Case Temperature Range	T _{stg}	-40	85	°C
Lead Soldering Temperature/Time	—	—	250/10	°C/s
Relative Humidity (noncondensing)	RH	—	85	%
Minimum Fiber-Bend Radius	—	1.00 (25.4)	—	in. (mm)

Characteristics (Min. and max. values specified over operating case temperature range at 50% duty cycle data signal. Typical values are measured at room temperature unless otherwise noted.)

Table 2. Electrical Characteristics

Parameter	Symbol	Min	Typ	Max	Unit
dc Power Supply Voltage	V _{CC}	4.75	5.0	5.25	V
dc Power Supply Current	I _{CC}	—	350	500	mA
dc Negative Supply Voltage	V _{EE}	-5.46	-5.2	-4.94	V
dc Negative Supply Current	I _{CC}	—	—	250	mA
Power Dissipation	P _{DISS}	—	4.5	6.5	W
Input Data/Clock Voltage: ^{1, 2} Single-ended Input	V _{IN}	250	900	1300	mVp-p
Differential Input	V _{IN}	125	450	650	mVp-p
Clocked/Nonclocked Select Voltage: ³ Clocked Operation (V _{IL})	V _{SEL_CLK}	0.0	—	0.8	V
Nonclocked Operation (V _{IH})	V _{DIS_CLK}	2.0	—	V _{CC}	V
Input Impedance	R _{IN}	—	50	—	Ω
Transmitter Disable Voltage (TTL) V _{IH}	V _{DIS}	2.0	—	V _{CC}	V
Transmitter Enable Voltage (TTL) V _{IL}	V _{EN}	0.0	—	0.8	V
λ Deviation Alarm: Levels (CMOS) V _{OL}	V _{λALARM N}	0	—	0.4	V
λ Deviation Alarm: Levels (CMOS) V _{OH}	V _{λALARM}	4.5	—	V _{CC}	V
Setting ⁴	λ _{ALARM}	-20	—	20	pm
Laser Degrade Alarm: Levels (CMOS) V _{OH}	V _{ALARM}	4.5	—	V _{CC}	V
Laser Degrade Alarm: Levels (CMOS) V _{OL}	V _{λALARM N}	0	—	0.4	V
Setting	LD _{ALARM}	—	—	60	mA

1. Inputs are ac-coupled internally into an equivalent input impedance of 50 Ω.

2. Single-ended or differential operation may be used. If the inputs are driven single-ended, the unused inputs must be terminated in 50 Ω.

3. Clocked operation is optional. For clocked operation, pin 5 must be a logic 1. With clocked operation, the optical output changes state with the rising edge of the input clock signal.

4. Deviation due to temperature variation detected by the thermistor.

Characteristics (continued)

Table 2. Electrical Characteristics (continued)

Parameter	Symbol	Min	Typ	Max	Unit
Laser Bias Monitor Voltage	V _{LBM}	—	20	—	mV/mA
Laser Monitor Voltage (50% duty cycle) ⁵	V _{BF}	—	500	—	mV/mW
TEC Current	I _{TEC}	—	0.6	1.3	A
TEC Voltage	V _{TEC}	3.0	3.3	3.5	V
Setup Time	T _{SET}	—	—	35	ps
Hold Time	T _{HOLD}	60	—	—	ps
Clock Duty Cycle	C _{DC}	40	50	60	%
Return Loss: Input Data ⁶	RL _{DATA}	-10	—	—	dB
Input Clock ⁷	RL _{CLOCK}	-12	—	—	dB

1. Inputs are ac-coupled internally into an equivalent input impedance of 50 Ω.
2. Single-ended or differential operation may used. If the inputs are driven single-ended, the unused inputs must be terminated in 50 Ω.
3. Clocked operation is optional. For clocked operation, pin 5 must a logic 1. If pin 5 is left floating, the transmitter operates in the clocked mode.
With clocked operation, the optical output changes state with the rising edge of the input clock signal.
4. Deviation due to temperature variation detected by the thermistor.
5. This voltage is measured from Pin 2 to GND.
6. Frequency range: 100 kHz—2 GHz.
7. At frequency of 2.5 GHz.

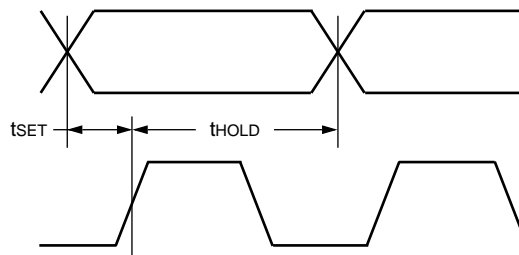

Figure 1. Electrical Input/Output Interface Timing Diagram

1-1087 (F)

Characteristics (continued)

Table 3. Optical Characteristics

Parameter	Symbol	Min	Typ	Max	Unit
Average Optical Power Output: ¹ BOL EOL	$P_{AVG\ BOL}$ $P_{AVG\ EOL}$	-2.0 TBD	— —	2 TBD	dBm dBm
Output Power Variation (BOL)	ΔP	-0.5	—	0.5	dBm
Wavelength Accuracy (room temperature)	$\Delta\lambda_C$	-0.015	—	0.015	nm
Center Wavelength Range (See Table 5.)	λ_C	1528.77	—	1563.86	nm
Variation in Center Wavelength over Temperature Range (EOL, all causes)	$\Delta\lambda_T$	-0.016	—	0.016	nm
Side-mode Suppression Ratio ²	SMSR	30	—	—	dB
Jitter, Intrinsic (12 kHz—20 MHz) ³	—	—	—	0.05	Ulp-p
Extinction Ratio ⁴	r_e	11.0	—	—	dB
Eye Mask of Optical Output ^{5, 6}	—	Meets SONET and ITU-T			—
Optical Rise/Fall Time (20%—80%)	t_R, t_F	—	—	125	ps
Maximum Return Loss (optical)	ORL	—	—	24	dB

1. Output power definitions and measurement per ITU-T Recommendation G.957.
2. Ratio of the average output power in the dominant longitudinal mode to the power in the most significant side mode under fully modulated conditions.
3. Filter bandwidth from 12 kHz—20 MHz, according to ITU-T G813.
4. Ratio of logic 1 output power to logic 0 output under fully modulated conditions.
5. GR-253-CORE, *Synchronous Optical Network (SONET) Transport Systems: Common Generic Criteria*.
6. ITU-T Recommendation G.957, *Optical Interfaces for Equipment and Systems Relating to the Synchronous Digital Hierarchy*.

Table 4. Dispersion Performance

Parameter	Symbol	Test Conditions	Min	Typ	Max	Unit
Dispersion Penalty for Extended Reach (360 km)	DP	6400 ps/nm	—	—	2.0	dB
Dispersion Penalty for Extended Reach (640 km)	DP	10500 ps/nm	—	—	2.0	dB

Outline Drawings

Dimensions are in inches and (millimeters).

Transmitter Package

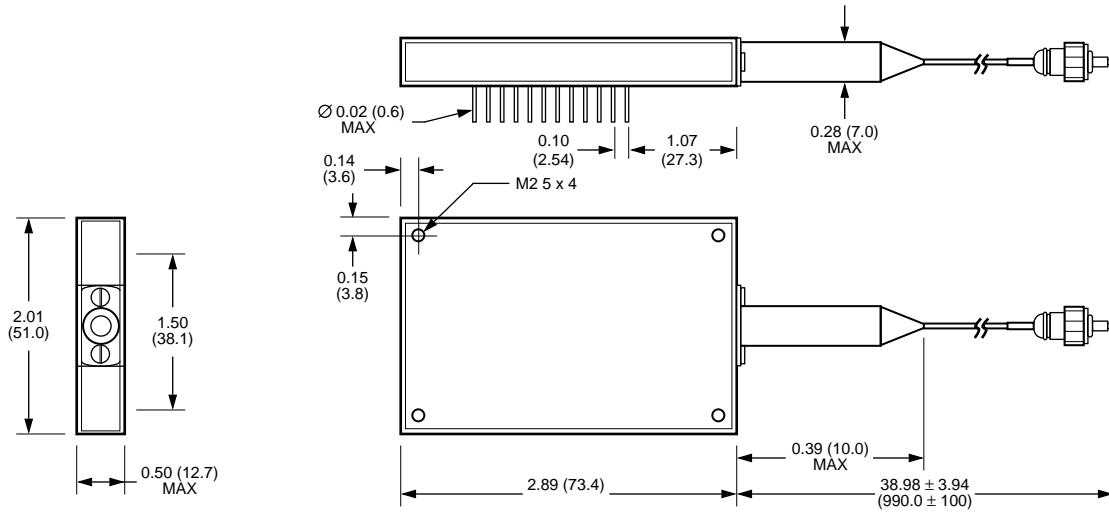

Transmitter Package with Standoffs

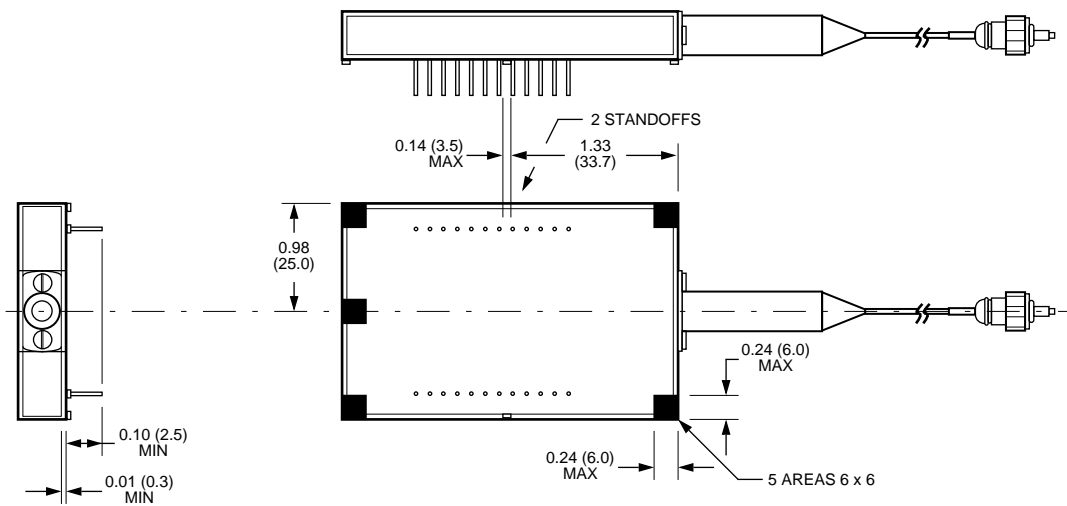

1-1050 (F).a

Qualification and Reliability

To help ensure high product reliability and customer satisfaction, Lucent is committed to an intensive quality program that starts in the design phase and proceeds through the manufacturing process. Optoelectronics modules are qualified to Lucent internal standards using MIL-STD-883 test methods and procedures and using sampling techniques consistent with *Telcordia Technologies* requirements. This qualification program fully meets the intent of Bellcore reliability practices TR-NWT-000468 and TA-TSY-000983. In addition, the Lucent Technologies Microelectronics Group Optoelectronics design, development, and manufacturing facility has been certified to be in full compliance with the latest *ISO*^{*}-9001 Quality System Standards.

Laser Safety Information

Class I Laser Product

FDA/CDHR laser products. The C488-Type Transmitters are Class I laser products per CDRH, 21 CFR 1040 Laser Safety requirements. All versions are Class I laser products per *IEC*[†] 60825-1:1993. The transmitters have been certified with the FDA under accession number 8720009.

This product complies with 21 CFR 1040.10 and 1040.11.

8 μm /125 μm diameter single-mode fiber pigtail with 914 μm tight-buffered jacket and connector

Wavelength = 1.5 μm

Maximum power = 10 mW

Product is not shipped with power supply.

Caution: Use of controls, adjustments, and procedures other than those specified herein may result in hazardous laser radiation exposure.

NOTICE
Unterminated optical connectors can emit laser radiation. Do not view with optical instruments.

* *ISO* is a registered trademark of The International Organization for Standardization.

† *IEC* is a registered trademark of The International Electrotechnical Commission.

Ordering Information

Table 5. Ordering Information

Product Code 360 km	Comcode 360 km	Product Code 640 km	Comcode 640 km	ITU Frequency (THz)	Center Wavelength (nm)
C488T517	108692658	C488T217	108695107	191.70 to 191.85	1563.86 to 1562.64
C488T519	108692666	C488T219	108695115	191.90 to 192.05	1562.23 to 1561.01
C488T521	108692674	C488T221	108695123	192.10 to 192.25	1560.61 to 1559.39
C488T523	108692682	C488T223	108695131	192.30 to 192.45	1558.98 to 1557.77
C488T525	108692690	C488T225	108695149	192.50 to 192.65	1557.36 to 1556.15
C488T527	108692708	C488T227	108695156	192.70 to 192.85	1555.75 to 1554.54
C488T529	108692716	C488T229	108695164	192.90 to 193.05	1554.13 to 1552.93
C488T531	108692724	C488T231	108695172	193.10 to 193.25	1552.52 to 1551.32
C488T533	108692732	C488T233	108695180	193.30 to 193.45	1550.92 to 1549.72
C488T535	108692740	C488T235	108695198	193.50 to 193.65	1549.32 to 1548.11
C488T537	108692757	C488T237	108695206	193.70 to 193.85	1547.72 to 1546.52
C488T539	108692765	C488T239	108695214	193.90 to 194.05	1546.12 to 1554.92
C488T541	108692773	C488T241	108695222	194.10 to 194.25	1544.53 to 1543.33
C488T543	108692781	C488T243	108695230	194.30 to 194.45	1542.94 to 1541.75
C488T545	108692799	C488T245	108695248	194.50 to 194.65	1541.35 to 1540.16
C488T547	108692807	C488T247	108695255	194.70 to 194.85	1539.77 to 1538.58
C488T549	108692815	C488T249	108695271	194.90 to 195.05	1538.19 to 1537.00
C488T551	108692823	C488T251	108695289	195.10 to 195.25	1536.61 to 1535.43
C488T553	108692831	C488T253	108695297	195.30 to 195.45	1535.04 to 1533.86
C488T555	108692849	C488T255	108695305	195.50 to 195.65	1533.47 to 1532.29
C488T557	108692856	C488T257	108695313	195.70 to 195.85	1531.90 to 1530.72
C488T559	108692864	C488T259	108695321	195.90 to 196.05	1530.33 to 1529.16

Ordering Information (continued)

Coding Scheme

Example: C488XXXX

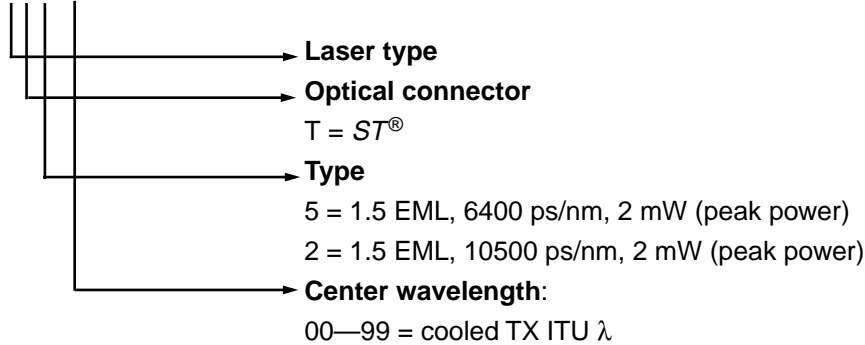

Related Product Information

Product Code	Description	Document Number
1320-Type Lightwave Receiver	Lightwave Receiver with Clock Recovery and Data Retiming for 2488.32 Mbits/s Applications	DS97-113LWP
1320 2.5 Gbits/s Receiver	Biasing and Interfacing to the 1320 2.5 Gbits/s Receiver	AP98-052LWP
R485-Type Lightwave Receiver	Lightwave Receiver with Clock Recover and Internal APD Bias Supply for 2.5 Gbits/s Applications	—

For additional information, contact your Microelectronics Group Account Manager or the following:

INTERNET: <http://www.lucent.com/micro>, or for Optoelectronics information, <http://www.lucent.com/micro/opto>

E-MAIL: docmaster@micro.lucent.com

N. AMERICA: Microelectronics Group, Lucent Technologies Inc., 555 Union Boulevard, Room 30L-15P-BA, Allentown, PA 18103
1-800-372-2447, FAX 610-712-4106 (In CANADA: **1-800-553-2448**, FAX 610-712-4106)

ASIA PACIFIC: Microelectronics Group, Lucent Technologies Singapore Pte. Ltd., 77 Science Park Drive, #03-18 Cintech III, Singapore 118256
Tel. (65) 778 8833, FAX (65) 777 7495

CHINA: Microelectronics Group, Lucent Technologies (China) Co., Ltd., A-F2, 23/F, Zao Fong Universe Building, 1800 Zhong Shan Xi Road, Shanghai 200233 P. R. China **Tel. (86) 21 6440 0468, ext. 316**, FAX (86) 21 6440 0652

JAPAN: Microelectronics Group, Lucent Technologies Japan Ltd., 7-18, Higashi-Gotanda 2-chome, Shinagawa-ku, Tokyo 141, Japan
Tel. (81) 3 5421 1600, FAX (81) 3 5421 1700

EUROPE: Data Requests: MICROELECTRONICS GROUP DATALINE: **Tel. (44) 7000 582 368**, FAX (44) 1189 328 148
Technical Inquiries: OPTOELECTRONICS MARKETING: **(44) 1344 865 900** (Ascot UK)

Lucent Technologies Inc. reserves the right to make changes to the product(s) or information contained herein without notice. No liability is assumed as a result of their use or application. No rights under any patent accompany the sale of any such product(s) or information. *ST* is a registered trademark of Lucent Technologies, Inc.

