

N-Channel Power MOSFET 50A, 200Volts

DESCRIPTION

The Nell **IRF260** is a three-terminal silicon device with current conduction capability of 50A, fast switching speed, low on-state resistance, breakdown voltage rating of 200V, and max. threshold voltage of 4 volts.

They are designed for use in applications such as switched mode power supplies, DC to DC converters, motor control circuits, UPS and general purpose switching applications.

FEATURES

- $R_{DS(ON)} = 0.055\Omega @ V_{GS} = 10V$
- Ultra low gate charge(230nC Max.)
- Low reverse transfer capacitance ($C_{RSS} = 310pF$ typical)
- Fast switching capability
- 100% avalanche energy specified
- Improved dv/dt capability
- 150°C operation temperature

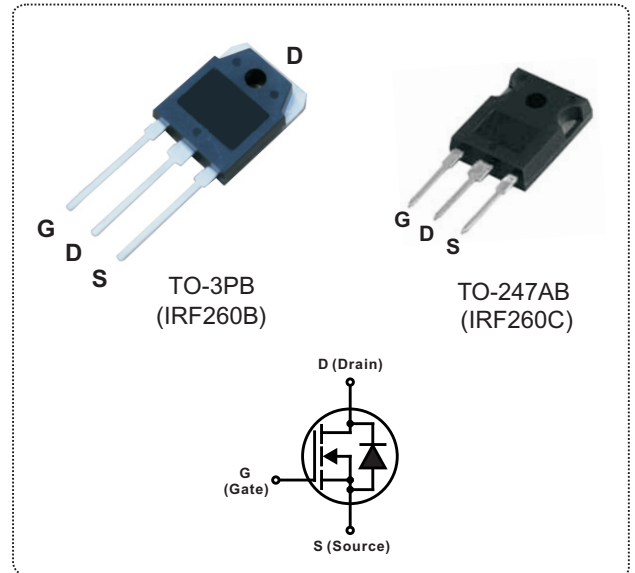

PRODUCT SUMMARY

I_D (A)	50
V_{DSS} (V)	200
$R_{DS(ON)}$ (Ω)	0.055 @ $V_{GS} = 10V$
Q_G (nC) max.	230

ABSOLUTE MAXIMUM RATINGS ($T_C = 25^\circ C$ unless otherwise specified)

SYMBOL	PARAMETER	TEST CONDITIONS	VALUE	UNIT
V_{DSS}	Drain to Source voltage	$T_J = 25^\circ C$ to $150^\circ C$	200	V
V_{DGR}	Drain to Gate voltage	$R_{GS} = 20K\Omega$	200	
V_{GS}	Gate to Source voltage		± 20	
I_D	Continuous Drain Current ($V_{GS} = 10V$)	$T_C = 25^\circ C$	50	A
		$T_C = 100^\circ C$	35	
I_{DM}	Pulsed Drain current(Note 1)		200	
I_{AR}	Avalanche current(Note 1)		50	
E_{AR}	Repetitive avalanche energy(Note 1)	$I_{AR} = 50A, R_{GS} = 50\Omega, V_{GS} = 10V$	28	mJ
E_{AS}	Single pulse avalanche energy(Note 2)	$I_{AS} = 50A, L = 0.7mH$	1000	
dv/dt	Peak diode recovery dv/dt(Note 3)		5.0	V / ns
P_D	Total power dissipation	$T_C = 25^\circ C$	280	W
	Derate above $25^\circ C$		2.2	W / $^\circ C$
T_J	Operation junction temperature		-55 to 150	$^\circ C$
T_{STG}	Storage temperature		-55 to 150	
T_L	Maximum soldering temperature, for 10 seconds	1.6mm from case	300	
	Mounting torque, #6-32 or M3 screw		10 (1.1)	lbf-in (N·m)

Note: 1. Repetitive rating: pulse width limited by junction temperature.
 2. $I_{AS} = 50A, L = 0.7mH, V_{DD} = 50V, R_G = 25\Omega$, starting $T_J = 25^\circ C$.
 3. $I_{SD} \leq 50A, di/dt \leq 230A/\mu s, V_{DD} \leq V_{(BR)DSS}$, starting $T_J < 150^\circ C$.

THERMAL RESISTANCE						
SYMBOL	PARAMETER	MIN.	TYP.	MAX.	UNIT	
$R_{th(j-c)}$	Thermal resistance, junction to case			0.45	°C/W	
$R_{th(c-s)}$	Thermal resistance, case to heat sink		0.24			
$R_{th(j-a)}$	Thermal resistance, junction to ambient			40		

ELECTRICAL CHARACTERISTICS ($T_C = 25^\circ\text{C}$ unless otherwise specified)						
SYMBOL	PARAMETER	TEST CONDITIONS	MIN.	TYP.	MAX.	UNIT
◎ STATIC						
$V_{(BR)DSS}$	Drain to source breakdown voltage	$I_D = 250\mu\text{A}, V_{GS} = 0\text{V}$	200			V
$\Delta V_{(BR)DSS}/\Delta T_J$	Breakdown voltage temperature coefficient	$I_D = 1\text{mA}, V_{DS} = V_{GS}$		0.24		V/°C
I_{DSS}	Drain to source leakage current	$V_{DS} = 200\text{V}, V_{GS} = 0\text{V}$			25.0	μA
		$V_{DS} = 160\text{V}, V_{GS} = 0\text{V}$			250	
I_{GSS}	Gate to source forward leakage current	$V_{GS} = 20\text{V}, V_{DS} = 0\text{V}$			100	nA
	Gate to source reverse leakage current	$V_{GS} = -20\text{V}, V_{DS} = 0\text{V}$			-100	
$R_{DS(ON)}$	Static drain to source on-state resistance	$I_D = 28\text{A}, V_{GS} = 10\text{V}$			0.055	Ω
$V_{GS(TH)}$	Gate threshold voltage	$V_{GS} = V_{DS}, I_D = 250\mu\text{A}$	2.0		4.0	V
g_{fs}	Forward transconductance	$V_{DS} = 50\text{V}, I_D = 28\text{A}$	24			S
◎ DYNAMIC						
C_{ISS}	Input capacitance	$V_{DS} = 25\text{V}, V_{GS} = 0\text{V}, f = 1\text{MHz}$		5200		μF
C_{OSS}	Output capacitance			1200		
C_{RSS}	Reverse transfer capacitance			310		
$t_{d(ON)}$	Turn-on delay time	$V_{DD} = 100\text{V}, V_{GS} = 10\text{V}$ $I_D = 50\text{A}, R_G = 4.3\Omega, R_D = 2.1\Omega$ (Note 1, 2)		23		ns
t_r	Rise time			120		
$t_{d(OFF)}$	Turn-off delay time			100		
t_f	Fall time			94		
Q_G	Total gate charge	$V_{DD} = 160\text{V}, V_{GS} = 10\text{V}$ $I_D = 50\text{A},$ (Note 1, 2)			230	nC
Q_{GS}	Gate to source charge				42	
Q_{GD}	Gate to drain charge (Miller charge)				110	
L_D	Internal drain inductance	Between lead, 6mm(0.25") form package and center of die contact		5		nH
L_S	Internal source inductance			13		

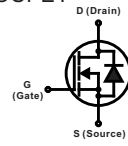
SOURCE TO DRAIN DIODE RATINGS AND CHARACTERISTICS ($T_C = 25^\circ\text{C}$ unless otherwise specified)						
SYMBOL	PARAMETER	TEST CONDITIONS	MIN.	TYP.	MAX.	UNIT
V_{SD}	Diode forward voltage	$I_{SD} = 50\text{A}, V_{GS} = 0\text{V}$			1.8	V
$I_S (I_{SD})$	Continuous source to drain current	Integral reverse P-N junction diode in the MOSFET 			50	A
I_{SM}	Pulsed source current				200	
t_{rr}	Reverse recovery time	$I_{SD} = 50\text{A}, V_{GS} = 0\text{V},$ $dI_F/dt = 100\text{A}/\mu\text{s}$		390	590	ns
Q_{rr}	Reverse recovery charge			4.8	7.2	μC

Note: 1. Pulse test: Pulse width $\leq 300\mu\text{s}$, duty cycle $\leq 2\%$.
2. Essentially independent of operating temperature.

ORDERING INFORMATION SCHEME

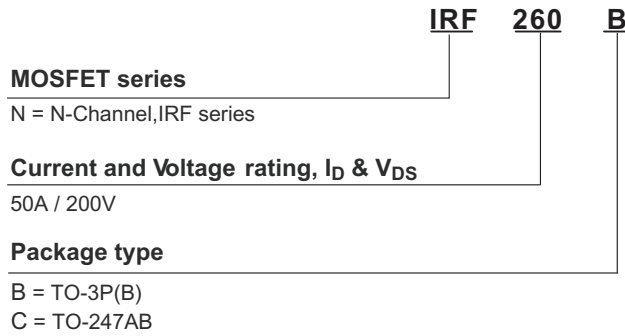

■ TYPICAL CHARACTERISTICS

Fig.1 Typical output characteristics, $T_C=25^\circ\text{C}$

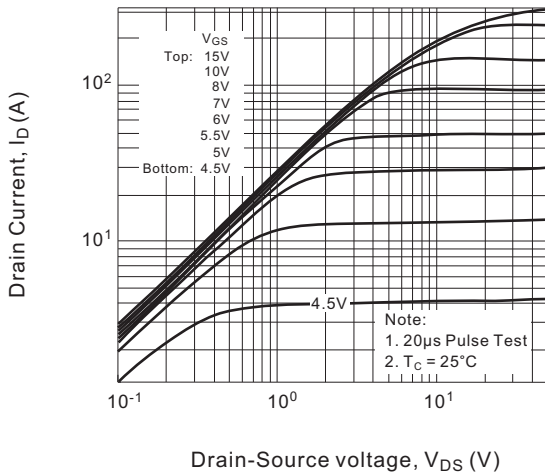

Fig.2 Typical output characteristics, $T_C=150^\circ\text{C}$

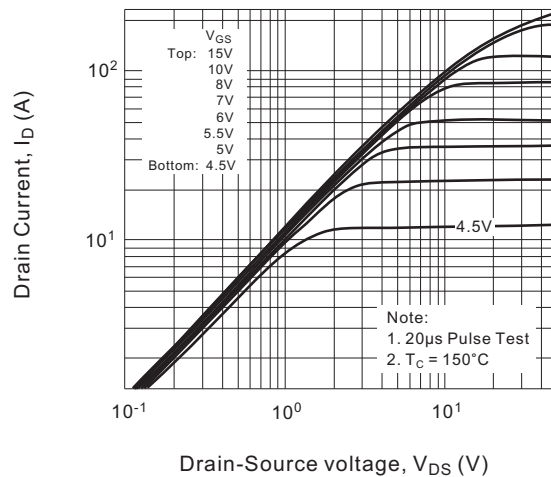

Fig.3 Typical transfer characteristics

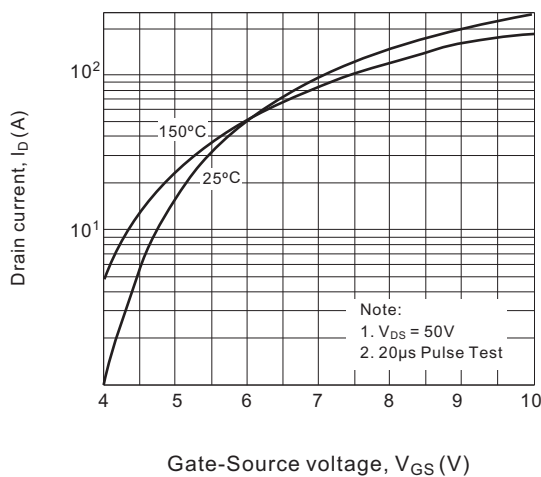

Fig.4 Normalized On-Resistance vs. Temperature

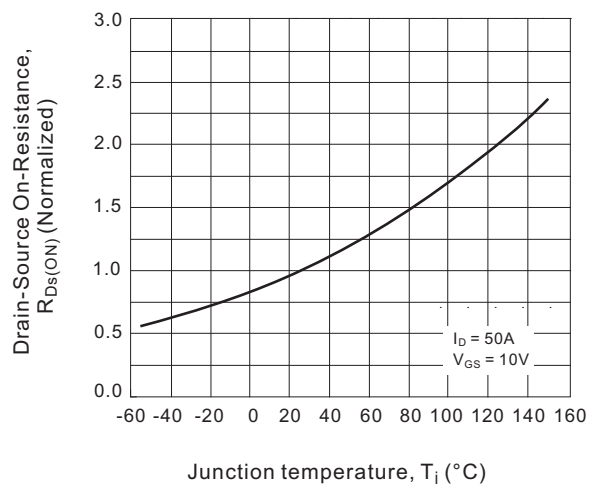

Fig.5 Typical capacitance vs. Drain-to-Source voltage

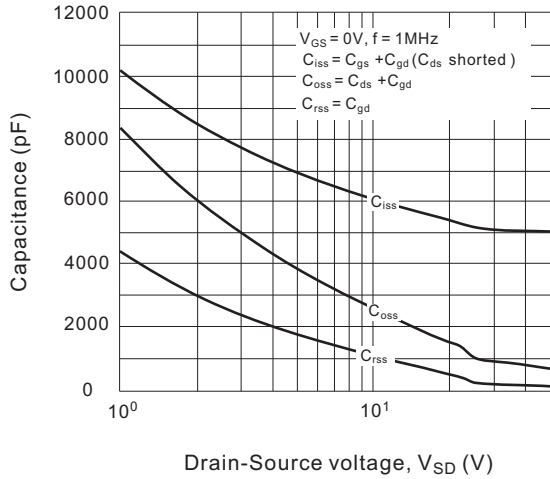

Fig.6 Typical source-drain diode forward voltage

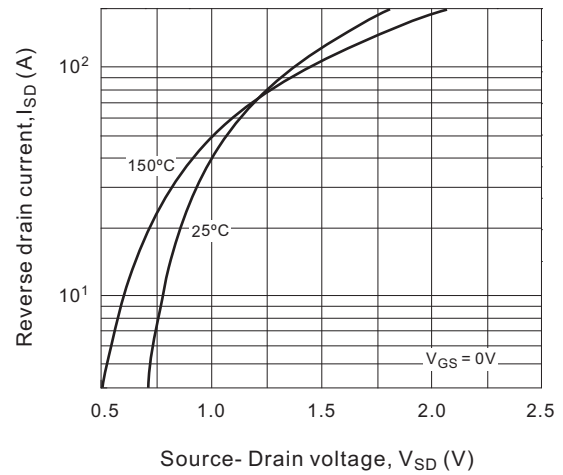

Fig.7 Typical gate charge vs. gate-to-source voltage

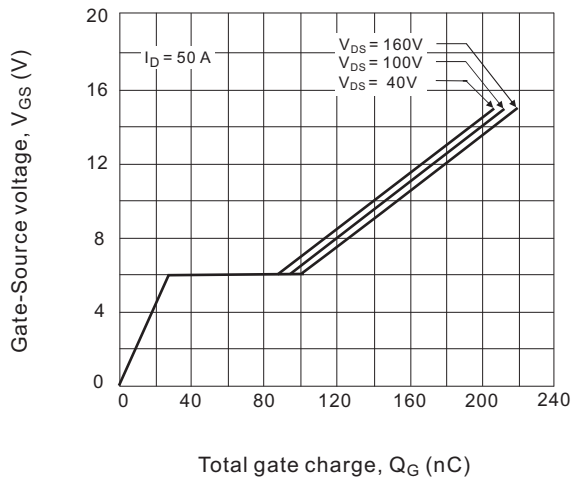

Fig.8 Maximum safe operating area

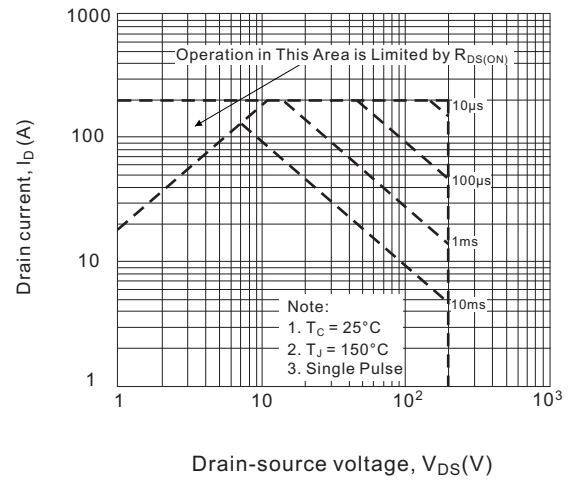

Fig.9 Maximum drain current vs. Case temperature

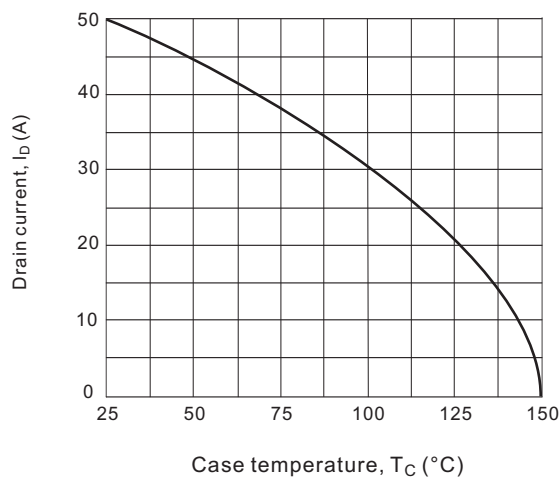

Fig.10 Maximum effective transient thermal impedance, Junction-to-Case

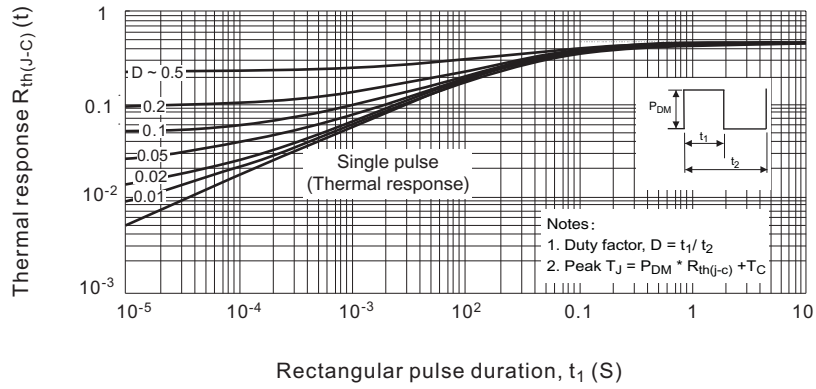

Fig.11a. Switching time test circuit

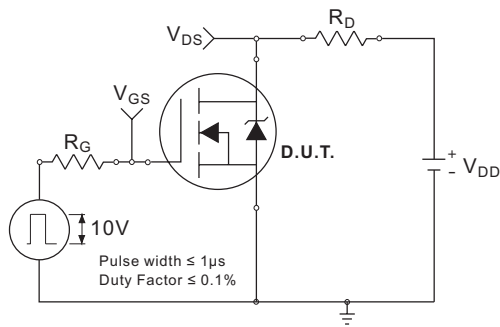

Fig.11b. Switching time waveforms

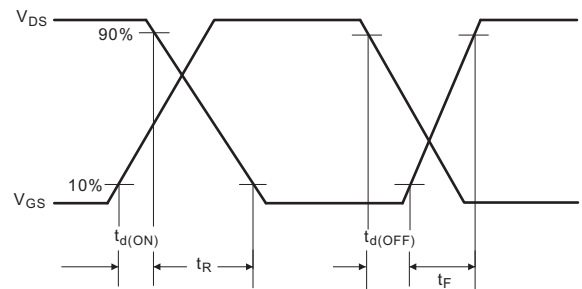

Fig.12a. Unclamped Inductive test circuit

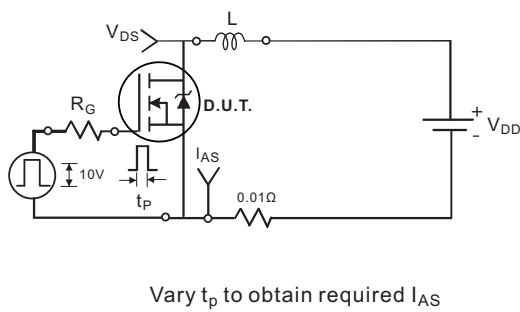

Fig.12b. Unclamped Inductive waveforms

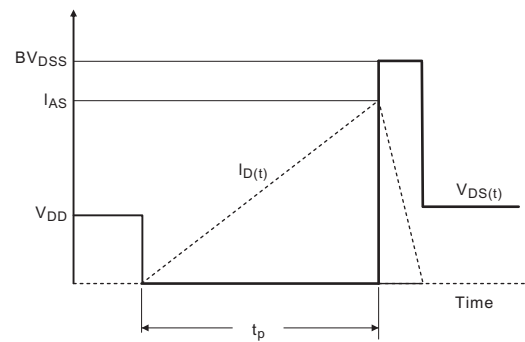

Fig.12c. Maximum avalanche energy vs. Drain current

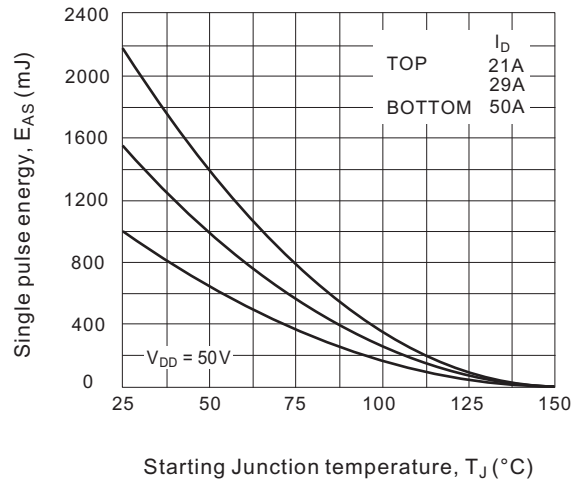

Fig.13a. Basic gate charge waveform

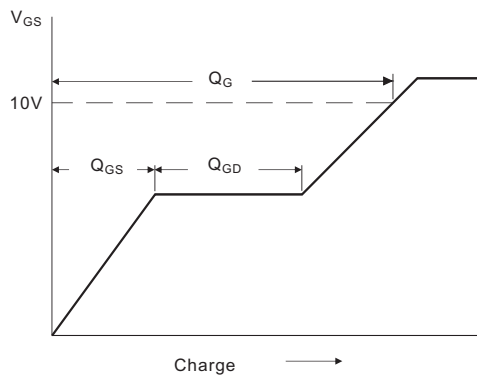

Fig.13b. Gate charge test circuit

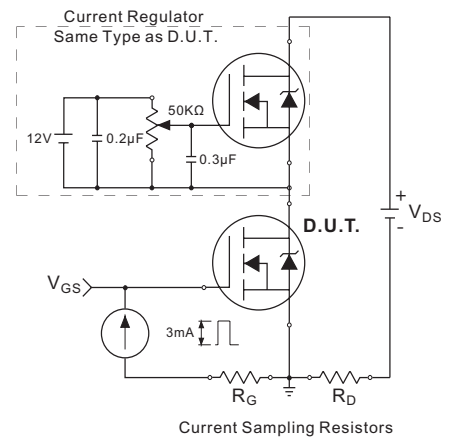
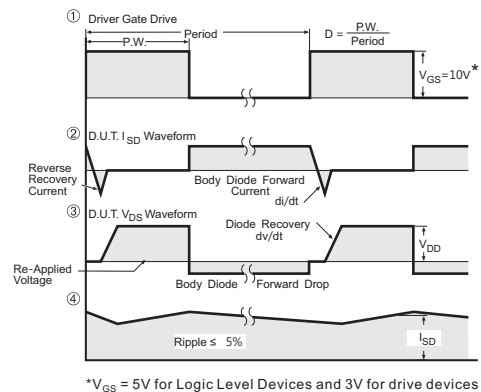
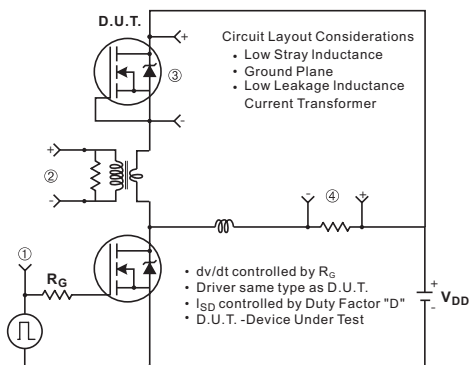
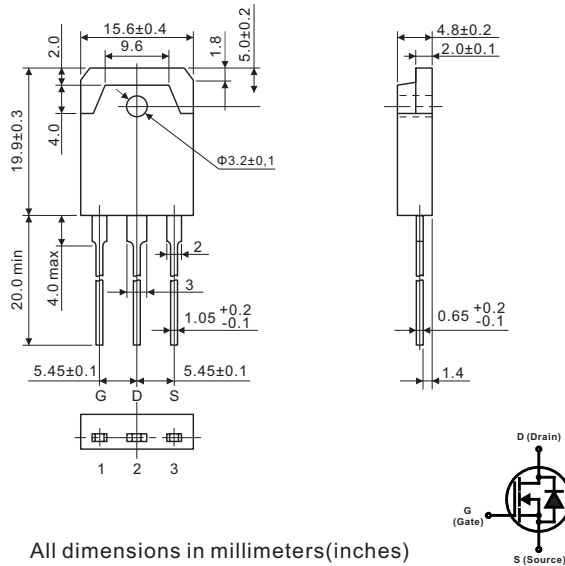

Fig.14 Peak diode recovery dv/dt test circuit for N-Channel MOSFET



TO-3PB



All dimensions in millimeters(inches)

TO-247AB

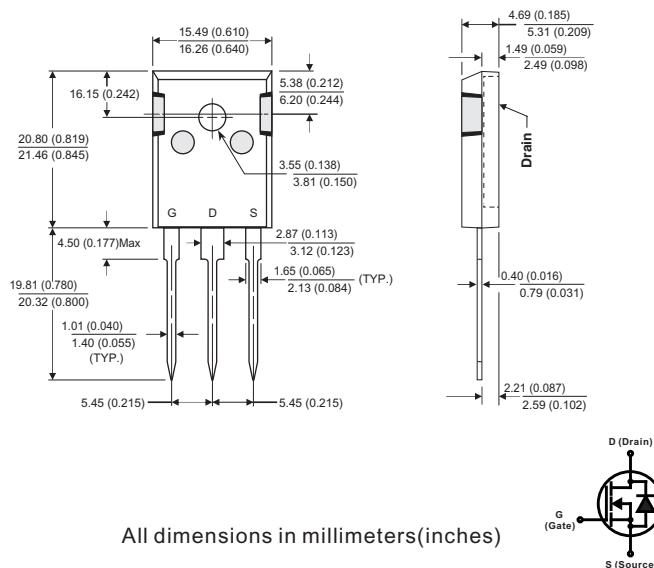

All dimensions in millimeters(inches)