

OV5653 5-megapixel product brief



available in
a lead-free
package

Industry-Leading Still Image Capture and 1080p Full HD Digital Video

The OV5653 is OmniVision's high-performance 5-megapixel imaging solution for digital still camera (DSC) and digital video (DV) applications, featuring 1.75 μm OmniBSI™ (backside illumination) technology. OmniBSI technology delivers a number of performance improvements over front-side illumination (FSI) technology, including increased sensitivity per unit area, improved quantum efficiency, reduced crosstalk and photo response non-uniformity, all of which lead to significant improvements in image quality.

The OV5653 delivers the industry's best low-light sensitivity at 1300 mV/lux-sec – a 40 percent improvement over previous FSI devices – and a 2x improvement in signal-to-noise ratio (<60 lux). Ideal for both 5-megapixel DSC and DV applications, the OV5653 delivers 720p video at 60 frames per second (fps) and full HD 1080p video at 30 fps, resulting in vivid still and video images, even in the most challenging lighting conditions.

Although the OV5653 is a RAW sensor, it includes a variety of automatic image control functions such as automatic exposure control, automatic 50/60 Hz luminance detection, and auto black level calibration.

The OV5653 also includes programmable user controls for image quality, formatting and output data transfer, mirror and flip, cropping, windowing and panning. The sensor's 256 bytes of embedded one-time programmable memory provide storage for custom information such as calibration parameters.

The OV5653 offers support for horizontal and vertical sub-sampling, and 2x2 binning. The embedded 1.5 volt regulator eliminates the need for additional power components.

The OV5653 – an ideal 5-megapixel solution for DSC and DV applications. Find out more at www.ovt.com.

Applications

- Digital Still and Video Cameras

Product Features

- 1.75 μm x 1.75 μm pixel with OmniBSI technology for high performance (high sensitivity, low crosstalk, low noise)
- support for horizontal and vertical sub-sampling and 2x2 binning
- automatic image control functions:
 - automatic exposure control (AEC)
 - automatic white balance (AWB)
 - automatic band filter (ABF)
 - automatic 50/60 Hz luminance detection
 - automatic black level calibration (ABLC)
- standard serial SCCB interface
- digital video port (DVP) parallel output interface
- MIPI interface (two lanes)
- programmable controls for frame rate, AEC/AGC 16-zone size/position/weight control, mirror and flip, cropping, windowing, and panning
- 256 bytes of embedded one-time programmable (OTP) memory
- on-chip phase lock loop (PLL)
- image quality controls: lens correction, 2-D defective pixel canceling
- embedded 1.5V regulator for core power
- support for output formats: 8/10-bit raw RGB data
- programmable I/O drive capability, I/O tri-state configurability
- support for video or snapshot operations
- support for black sun cancellation
- support for LED and flash strobe mode
- suitable for module size of 8.5 x 8.5 x 6 mm
- support for internal and external frame synchronization for frame exposure mode

OV5653

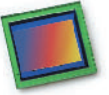

Ordering Information

- OV05653-A66A (color, lead-free, 66-pin CSP3)

Product Specifications

- active array size: 2592 x 1944
- max S/N ratio: 37 dB
- power supply:
 - core: 1.5V \pm 5% (with embedded 1.5V regulator)
 - analog: 2.6 - 3.0V (2.8V typical)
 - I/O: 1.8V/2.8V
- dynamic range: 69 dB @ 8x gain
- power requirements:
 - active: 150 mA
 - standby: 40 μA
- maximum image transfer rate:
 - QSXGA (2592x1944): 15 fps
 - 1080p: 30 fps
 - 720p: 60 fps
 - VGA (640x480): 90 fps
 - QVGA (320x240): 120 fps
- temperature range:
 - operating: -30°C to 85°C junction temperature
 - stable image: 0°C to 65°C junction temperature
- sensitivity: 1300 mV/lux-sec
- shutter: rolling shutter
- output formats: 8/10-bit RAW RGB output
- maximum exposure interval: 1968 x t_{row}
- lens size: 1/3.2"
- pixel size: 1.75 μm x 1.75 μm
- lens chief ray angle: 11.2° non-linear
- dark current: 8 mV/sec @ 50°C junction temperature
- input clock frequency: 6 - 27 MHz
- image area: 4592 μm x 3423 μm
- package dimensions: 6505 μm x 6005 μm

Functional Block Diagram

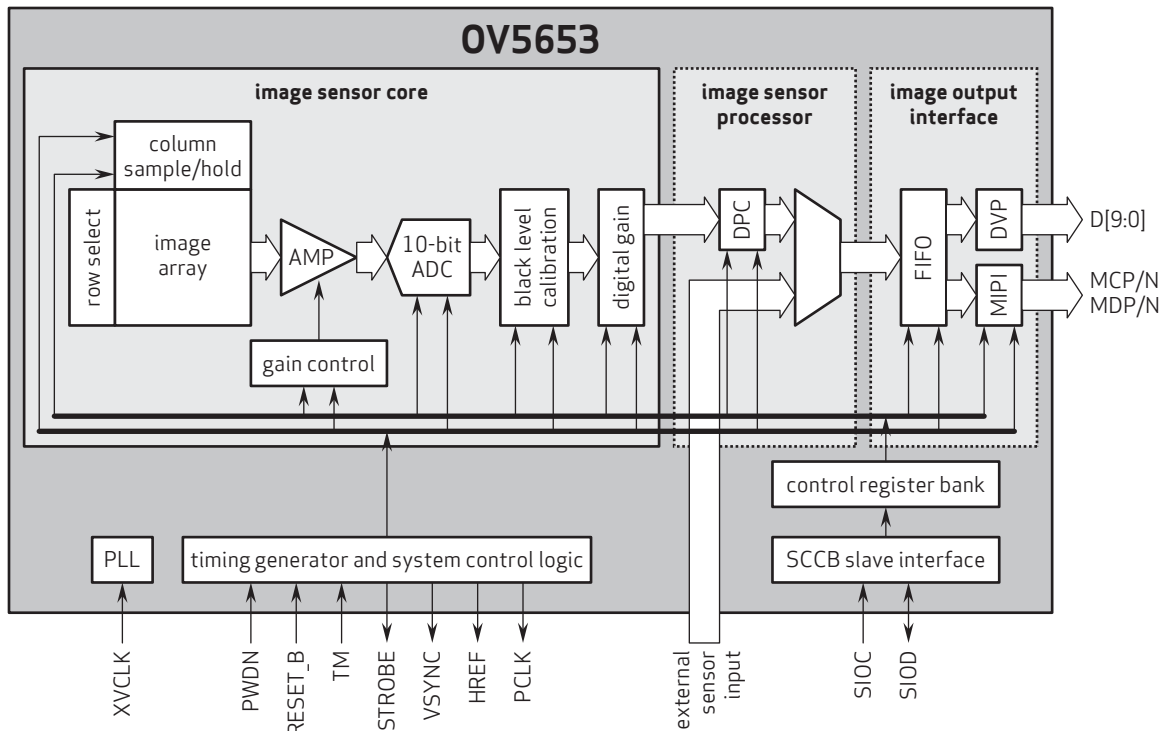

4275 Burton Drive
Santa Clara, CA 95054
USA

Tel: + 1 408 567 3000
Fax: + 1 408 567 3001
www.ovt.com

OmniVision reserves the right to make changes to their products or to discontinue any product or service without further notice. OmniVision and the OmniVision logo are registered trademarks of OmniVision Technologies, Inc. OmniBSI is a trademark of OmniVision Technologies, Inc. All other trademarks are the property of their respective owners.

OmniVision