

Silicon PNP triple diffusion planar transistor -15A/-230V/150W

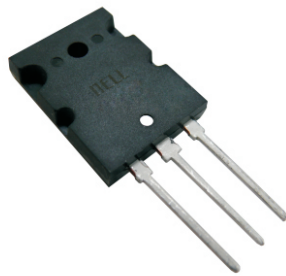

TO-3PL

FEATURES

- High breakdown voltage, $V_{CE0} = -230V$ (min)
- Complementary to 2SC5200BL
- TO-3PL package which can be installed to the heat sink with one screw

APPLICATIONS

- Suitable for use in 100W high fidelity audio amplifier's output stage

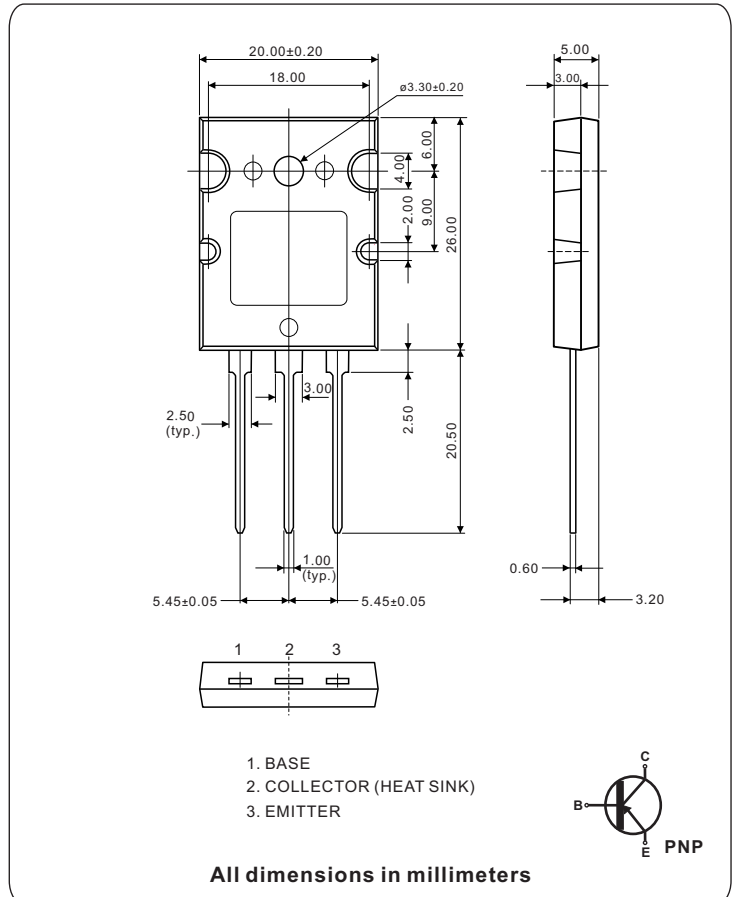

ABSOLUTE MAXIMUM RATINGS ($T_a = 25^\circ C$)

SYMBOL	PARAMETER	VALUE	UNIT
V_{CBO}	Collector to base voltage	-230	V
V_{CEO}	Collector to emitter voltage	-230	
V_{EBO}	Emitter to base voltage	-5	
I_{CP}	Peak collector current $t_p \leq 5$ ms	-30	A
I_C	Collector current	-15	
I_B	Base current	-1.5	
P_C	Collector power dissipation	$T_C = 25^\circ C$ 150	W
T_j	Junction temperature	150	$^\circ C$
T_{stg}	Storage temperature	-55 to 150	

THERMAL CHARACTERISTICS ($T_C = 25^\circ C$)

SYMBOL	PARAMETER	VALUE	UNIT
$R_{th(j-c)}$	Maximum thermal resistance, junction to case	1.10	$^\circ C/W$

ELECTRICAL CHARACTERISTICS (T _a = 25°C)						
SYMBOL	PARAMETER	CONDITIONS	VALUE			UNIT
			MIN.	TYP.	MAX.	
I _{CBO}	Collector cutoff current	V _{CB0} = -230V, I _E = 0			-5.0	μA
I _{EBO}	Emitter cutoff current	V _{EBO} = -5V, I _C = 0			-5.0	
V _{(BR)CEO}	Collector to emitter breakdown voltage	I _{CEO} = -50mA, I _B = 0	-230			V
V _{CB0}	Collector to base voltage	I _{CBO} = -100 μA	-230			
V _{EBO}	Emitter to base voltage	I _{EBO} = -100 μA	-5			
h _{FE1}	Forward current transfer ratio (DC current gain)	V _{CE} = -5V, I _C = -1A	Rank-R	55		110
			Rank-O	80		160
h _{FE2}		V _{CE} = -5V, I _C = -7A	35	60		
V _{CE(sat)}	Collector to emitter saturation voltage	I _C = -8A, I _B = -0.8A		-1.5	-3.0	V
V _{BE}	Base to emitter voltage	V _{CE} = -5V, I _C = -7A		-1.0	-1.5	
f _T	Transition frequency (Gain-Bandwidth product)	V _{CE} = -5V, I _C = -1A		30		MHz
C _{ob}	Collector output capacitance	V _{CB} = -10V, I _E = 0, f = 1MHz		360		pF

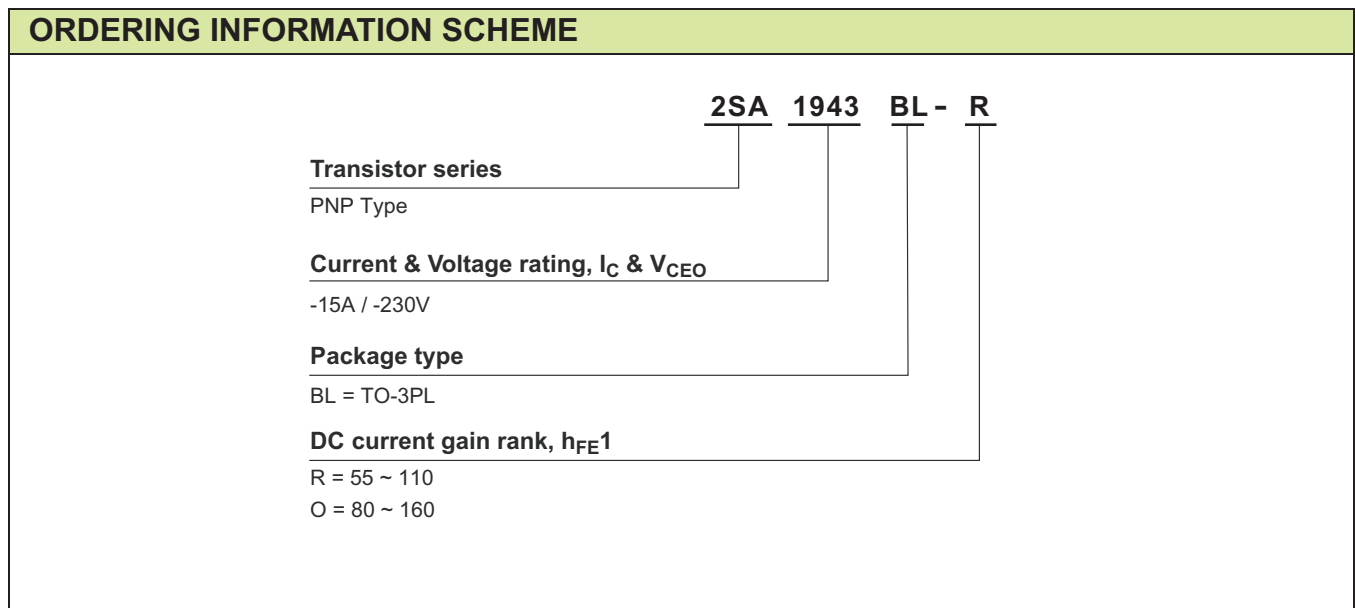

Fig.1 $I_C - V_{CE}$

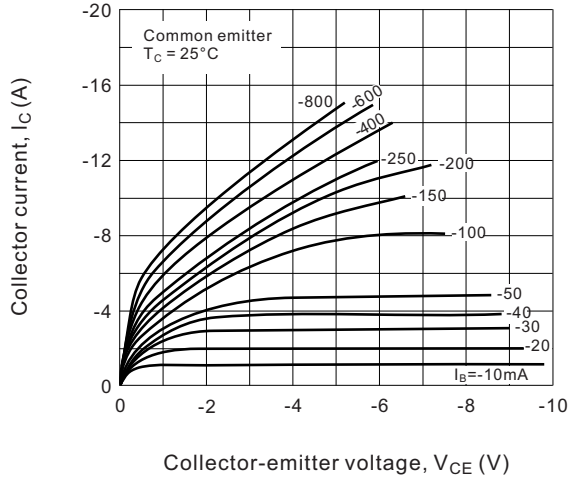

Fig.2 $V_{CE(sat)} - I_C$

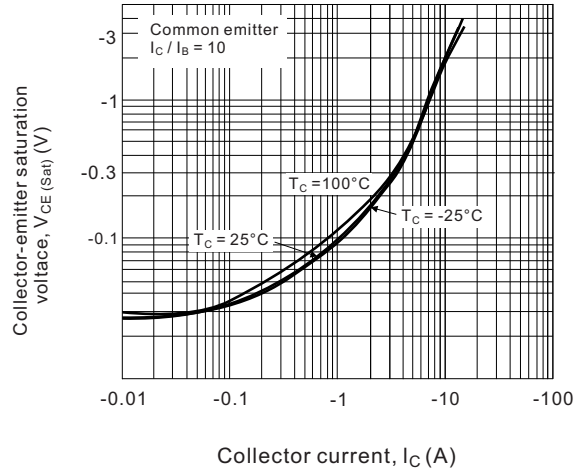

Fig.3 $I_C - V_{BE}$

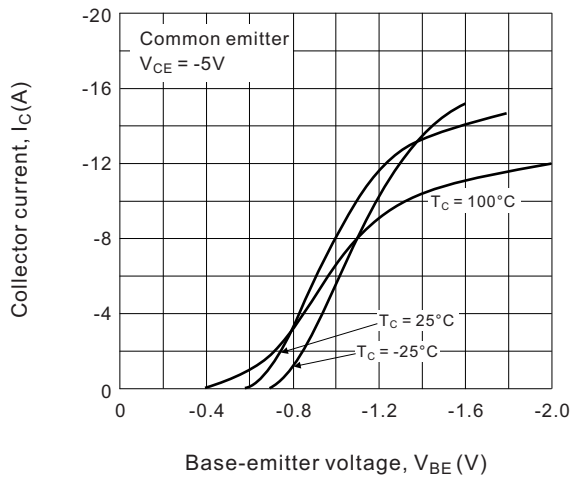

Fig.4 DC current gain

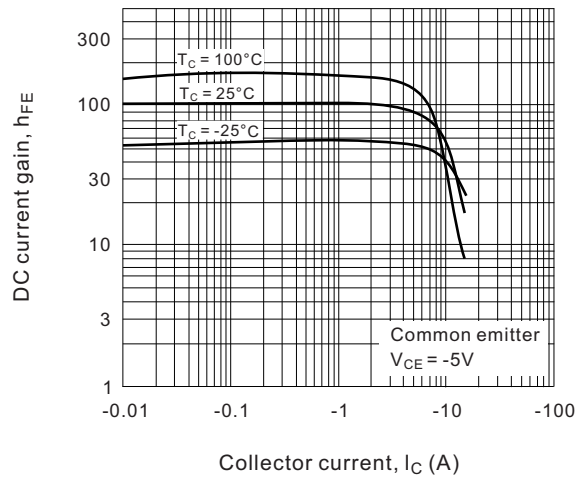

Fig.5 Safe operating area

