

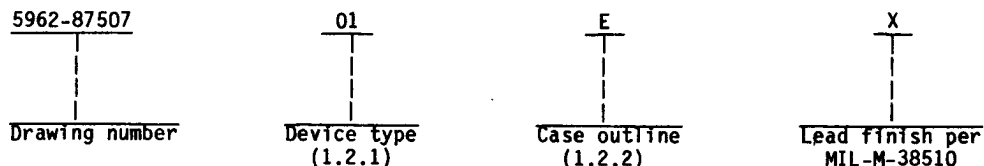

1. SCOPE

1.1 Scope. This drawing describes device requirements for class B microcircuits in accordance with 1.2.1 of MIL-STD-883, "Provisions for the use of MIL-STD-883 in conjunction with compliant non-JAN devices".

1.2 Part number. The complete part number shall be as shown in the following example:



1.2.1 Device type. The device type shall identify the circuit function as follows:

Device type	Generic number	Circuit function
01	10H505	Triple 2-3-2 input OR/NOR gate

1.2.2 Case outlines. The case outlines shall be as designated in appendix C of MIL-M-38510, and as follows:

Outline letter	Case outline
E	D-2 (16-lead, .840" x .310" x .200"), dual-in-line package
F	F-5 (16-lead, .440" x .285" x .085"), flat package
2	C-2 (20-terminal, .358" x .358" x .100"), square chip carrier package

1.3 Absolute maximum ratings.

Supply voltage range	-8.0 V to 0.0 V
Input voltage range	-5.2 V to 0.0 V
Storage temperature range	-65°C to +165°C
Lead temperature (soldering, 10 seconds)	+300°C
Junction temperature (T <sub>J</sub> )	+165°C
Maximum power dissipation (P <sub>D</sub> )	171 mW
Thermal resistance, junction-to-case (θ <sub>JC</sub> )	See MIL-M-38510, appendix C

1.4 Recommended operating conditions.

Supply voltage range (V <sub>EE</sub> )	-5.46 V minimum to -4.94 V maximum
Supply voltage range (V <sub>CC</sub> )	-0.02 V to +0.02 V or 1.98 V to 2.02 V
Ambient operating temperature range (T <sub>A</sub> )	-55°C to +125°C
Minimum high level input voltage (V <sub>IH</sub> ):	
T <sub>A</sub> = +25°C	-0.780 V
T <sub>A</sub> = +125°C	-0.650 V
T <sub>A</sub> = -55°C	-0.840 V
Maximum low level input voltage (V <sub>IL</sub> )	-1.950 V

<b>STANDARDIZED MILITARY DRAWING</b> DEFENSE ELECTRONICS SUPPLY CENTER DAYTON, OHIO 45444	SIZE <b>A</b>	5962-87507
	REVISION LEVEL A	SHEET 2

DESC FORM 193A  
SEP 87

\* U. S. GOVERNMENT PRINTING OFFICE: 1988-548-904

**2. APPLICABLE DOCUMENTS**

2.1 Government specification and standard. Unless otherwise specified, the following specification and standard, of the issue listed in that issue of the Department of Defense Index of Specifications and Standards specified in the solicitation, form a part of this drawing to the extent specified herein.

**SPECIFICATION**

**MILITARY**

MIL-M-38510 - Microcircuits, General Specification for.

**STANDARD**

**MILITARY**

MIL-STD-883 - Test Methods and Procedures for Microelectronics.

(Copies of the specification and standard required by manufacturers in connection with specific acquisition functions should be obtained from the contracting activity or as directed by the contracting activity.)

2.2 Order of precedence. In the event of a conflict between the text of this drawing and the references cited herein, the text of this drawing shall take precedence.

**3. REQUIREMENTS**

3.1 Item requirements. The individual item requirements shall be in accordance with 1.2.1 of MIL-STD-883, "Provisions for the use of MIL-STD-883 in conjunction with compliant non-JAN devices" and as specified herein.

3.2 Design, construction, and physical dimensions. The design, construction, and physical dimensions shall be as specified in MIL-M-38510 and herein.

3.2.1 Terminal connections. The terminal connections shall be as specified on figure 1.

3.2.2 Truth tables. The truth tables shall be as specified on figure 2.

3.2.3 Logic diagram. The logic diagram shall be as specified on figure 3.

3.2.4 Test circuit and switching waveforms. Test circuit and switching waveforms shall be as specified on figure 4.

3.2.5 Case outlines. The case outlines shall be in accordance with 1.2.2 herein.

3.3 Electrical performance characteristics. Unless otherwise specified, the electrical performance characteristics are as specified in table I and apply over the full ambient operating temperature range.

3.4 Marking. Marking shall be in accordance with MIL-STD-883 (see 3.1 herein). The part shall be marked with the part number listed in 1.2 herein. In addition, the manufacturer's part number may also be marked as listed in 6.4 herein.

<b>STANDARDIZED MILITARY DRAWING</b> DEFENSE ELECTRONICS SUPPLY CENTER DAYTON, OHIO 45444	SIZE <b>A</b>		5962-87507
		REVISION LEVEL A	SHEET 3

DESC FORM 193A  
SEP 87

U. S. GOVERNMENT PRINTING OFFICE: 1988-560-647

TABLE I. Electrical performance characteristics.

Test	Symbol	Conditions -55°C < T <sub>A</sub> < +125°C unless otherwise specified	Group A subgroups	Limits		Unit		
				Min	Max			
Cases E, F, and 2		Quiescent conditions <u>1/</u>						
High level output voltage	V <sub>OH</sub>	Outputs terminated through 100Ω to -2.0 V	V <sub>IH</sub>	V <sub>IL</sub>				
			-0.780	-1.950	1	-1.010	-0.780	V
			-0.650	-1.950	2	-0.860	-0.650	
Low level output voltage	V <sub>OL</sub>	V <sub>EE</sub> = -5.2 V V <sub>CC</sub> = 0.0 V <u>2/</u>	-0.780	-1.950	1	-1.950	-1.580	V
			-0.650	-1.950	2	-1.950	-1.565	
			-0.840	-1.950	3	-1.950	-1.610	
High level threshold output voltage	V <sub>OHA</sub>		-1.110	-1.480	1	-1.010	-0.780	V
			-0.960	-1.465	2	-0.860	-0.650	
			-1.160	-1.510	3	-1.060	-0.840	
Low level threshold output voltage	V <sub>OLA</sub>		-1.110	-1.480	1	-1.950	-1.580	V
			-0.960	-1.465	2	-1.950	-1.565	
			-1.160	-1.510	3	-1.950	-1.610	
Power supply drain current <u>3/</u>	I <sub>EE</sub>	V <sub>EE</sub> = -5.46 V V <sub>CC</sub> = 0.0 V			1 2, 3	-21 -23	mA	
High level input current	I <sub>IH</sub>	V <sub>IH</sub> = -0.780 V at +25°C = -0.650 V at +125°C = -0.840 V at -55°C			1, 2 3	265 425	μA	
Low level input current	I <sub>IL</sub>	V <sub>EE</sub> = -4.95 V <u>3/</u> V <sub>IL</sub> = -1.950 V V <sub>CC</sub> = 0.0 V			1, 3 2	0.5 0.3	μA	
Functional tests		See 4.3.1c			7, 8			

See footnotes at end of table.

<b>STANDARDIZED MILITARY DRAWING</b> DEFENSE ELECTRONICS SUPPLY CENTER DAYTON, OHIO 45444	SIZE <b>A</b>		5962-87507
		REVISION LEVEL <b>A</b>	SHEET <b>4</b>

DESC FORM 193A  
SEP 87

\* U. S. GOVERNMENT PRINTING OFFICE: 1986-549-904

TABLE I. Electrical performance characteristics - Continued

Test	Symbol	Conditions -55°C < T <sub>A</sub> < +125°C unless otherwise specified	Group A subgroups	Limits		Unit		
				Min	Max			
Cases E and F		DC rapid test conditions 4/						
High level output voltage	V <sub>OH</sub>	Outputs terminated through 100Ω to -2 V	V <sub>IH</sub>	V <sub>IL</sub>				
			-0.788	-1.950	1	-1.017   -0.788	V	
			-0.658	-1.950	2	-0.868   -0.658		
Low level output voltage	V <sub>OL</sub>	V <sub>CC</sub> = 0.0 V V <sub>EE</sub> = -5.2 V 2/	-0.788	-1.950	1	-1.950   -1.582	V	
			-0.658	-1.950	2	-1.950   -1.568		
			-0.848	-1.950	3	-1.950   -1.613		
High level threshold output voltage	V <sub>OHA</sub>		-1.117	-1.482	1	-1.017   -0.788	V	
			-0.968	-1.468	2	-0.868   -0.658		
			-1.168	-1.513	3	-1.068   -0.848		
Low level threshold output voltage	V <sub>OLA</sub>		-1.117	-1.482	1	-1.950   -1.582	V	
			-0.968	-1.468	2	-1.950   -1.568		
			-1.168	-1.513	3	-1.950   -1.613		
Power supply drain current 3/	I <sub>EE</sub>	V <sub>EE</sub> = -5.46 V V <sub>CC</sub> = 0.0 V			1 2, 3	-20 -22	mA	
High level input current	I <sub>IH</sub>	V <sub>IH</sub> = -0.788 V at +25°C = -0.658 V at +125°C = -0.848 V at -55°C			1, 2 3		250 410	μA
Low level input current	I <sub>IL</sub>	V <sub>EE</sub> = -4.94 V 3/ V <sub>IL</sub> = -1.950 V V <sub>CC</sub> = 0.0 V			1, 3 2	0.5 0.3		μA
Functional tests		See 4.3.1c			7, 8			

See footnotes at end of table.

<b>STANDARDIZED MILITARY DRAWING</b> DEFENSE ELECTRONICS SUPPLY CENTER DAYTON, OHIO 45444	SIZE <b>A</b>		5962-87507
		REVISION LEVEL A	SHEET 5

DESC FORM 193A  
SEP 87

\* U. S. GOVERNMENT PRINTING OFFICE: 1988-549-904

TABLE I. Electrical performance characteristics - Continued

Test	Symbol	Conditions -55°C < T <sub>A</sub> < +125°C unless otherwise specified	Group A subgroups	Limits		Unit		
				Min	Max			
Case 2		DC rapid test conditions 4/						
High level output voltage	V <sub>OH</sub>	Outputs terminated through 100Ω to -2 V	V <sub>IH</sub>	V <sub>IL</sub>				
			-0.793	-1.950	1	-1.022	-0.793	V
			-0.664	-1.950	2	-0.873	-0.664	
-0.854	-1.950	3	-1.073	-0.854				
Low level output voltage	V <sub>OL</sub>	V <sub>CC</sub> = 0.0 V V <sub>EE</sub> = -5.2 V 2/	-0.793	-1.950	1	-1.950	-1.584	V
			-0.664	-1.950	2	-1.950	-1.569	
			-0.854	-1.950	3	-1.950	-1.614	
High level threshold output voltage	V <sub>OHA</sub>		-1.122	-1.484	1	-1.022	-0.793	V
			-0.973	-1.469	2	-0.873	-0.664	
			-1.173	-1.514	3	-1.073	-0.854	
Low level threshold output voltage	V <sub>OLA</sub>		-1.122	-1.484	1	-1.950	-1.584	V
			-0.973	-1.469	2	-1.950	-1.569	
			-1.173	-1.514	3	-1.950	-1.614	
Power supply drain current 3/	I <sub>EE</sub>	V <sub>EE</sub> = -5.46 V V <sub>CC</sub> = 0.0 V V <sub>IH</sub> = -0.793 V at +25°C = -0.664 V at +125°C = -0.854 V at -55°C			1 2, 3	-20 -22		mA
High level input current	I <sub>IH</sub>				1, 2 3		250 410	μA
Low level input current	I <sub>IL</sub>	V <sub>EE</sub> = -4.94 V 3/ V <sub>IL</sub> = -1.950 V V <sub>CC</sub> = 0.0 V			1, 3 2	0.5 0.3		μA
Functional tests		See 4.3.1c			7, 8			

See footnotes on next page.

<b>STANDARDIZED MILITARY DRAWING</b> DEFENSE ELECTRONICS SUPPLY CENTER DAYTON, OHIO 45444	SIZE <b>A</b>		5962-87507
		REVISION LEVEL A	SHEET 6

DESC FORM 193A  
SEP 87

\* U. S. GOVERNMENT PRINTING OFFICE: 1988-549-904

TABLE I. Electrical performance characteristics - Continued.

Test	Symbol	Conditions -55°C < T <sub>A</sub> < +125°C unless otherwise specified	Group A subgroups	Limits		Unit
				Min	Max	
Cases E, F, and 2			AC test conditions			
Transition time	t <sub>TLH</sub> t <sub>THL</sub>	V <sub>EE</sub> = -2.94 V V <sub>CC</sub> = 2.0 V C <sub>L</sub> < 5 pF Load all outputs through 100Ω to ground See figure 4	9	0.50	1.40	ns
			10	0.65	1.50	
			11	0.40	1.30	
Propagation delay time A, B, C to Y	t <sub>PHH</sub>		9	0.45	1.40	ns
			10	0.45	1.60	
			11	0.45	1.50	
	t <sub>PLL</sub>		9	0.40	1.40	ns
			10	0.40	1.50	
			11	0.40	1.30	
	t <sub>PHL</sub>		9	0.45	1.60	ns
			10	0.45	1.60	
			11	0.45	1.50	
	t <sub>PLH</sub>		9	0.40	1.40	ns
			10	0.40	1.60	
			11	0.40	1.20	

1/ The quiescent limits are determined after a device has reached thermal equilibrium. This is defined as the reading taken with the device in a socket with > 500 LFPM of +25°C, +125°C or -55°C (as applicable) air blowing on the unit in a transverse direction with power applied for at least 4 minutes before the reading is taken. This method was used for theoretical limit establishment only. All devices shall be tested to the delta V (rapid test) conditions specified herein. The rapid test method is an equivalent method of testing quiescent conditions.

2/ The high and low level output current varies with temperature, and shall be calculated using the following formulas:  
 $I_{OH} = (V_{OH} - 2 V)/100\Omega$   
 $I_{OL} = (V_{OL} - 2 V)/100\Omega$

3/ The I<sub>EE</sub> and I<sub>IL</sub> limits, although specified in the minimum column, shall not be exceeded, in magnitude, as a maximum value.

4/ The dc rapid test forcing functions and limits are used for all dc testing. These limits are determined for each device type based on the power dissipation and package type. The rapid test (delta V) limits and forcing functions are skewed allowing rapid testing to be performed at standard temperatures without the addition of delta T's.

3.5 Certificate of compliance. A certificate of compliance shall be required from a manufacturer in order to be listed as an approved source of supply in 6.4. The certificate of compliance submitted to DESC-ECS prior to listing as an approved source of supply shall state that the manufacturer's product meets the requirements of MIL-STD-883 (see 3.1 herein) and the requirements herein.

<b>STANDARDIZED MILITARY DRAWING</b> DEFENSE ELECTRONICS SUPPLY CENTER DAYTON, OHIO 45444	SIZE <b>A</b>	5962-87507
	REVISION LEVEL A	SHEET 7

DESC FORM 193A  
SEP 87

\* U. S. GOVERNMENT PRINTING OFFICE: 1988-549-904

3.6 Certificate of conformance. A certificate of conformance as required in MIL-STD-883 (see 3.1 herein) shall be provided with each lot of microcircuits delivered to this drawing.

3.7 Notification of change. Notification of change to DESC-ECS shall be required in accordance with MIL-STD-883 (see 3.1 herein).

3.8 Verification and review. DESC, DESC's agent, and the acquiring activity retain the option to review the manufacturer's facility and applicable required documentation. Offshore documentation shall be made available onshore at the option of the reviewer.

4. QUALITY ASSURANCE PROVISIONS

4.1 Sampling and inspection. Sampling and inspection procedures shall be in accordance with section 4 of MIL-M-38510 to the extent specified in MIL-STD-883 (see 3.1 herein).

4.2 Screening. Screening shall be in accordance with method 5004 of MIL-STD-883, and shall be conducted on all devices prior to quality conformance inspection. The following additional criteria shall apply:

- a. Burn-in test, method 1015 of MIL-STD-883.
  - (1) Test condition A, B, C, or D using the circuit submitted with the certificate of compliance (see 3.5 herein).
  - (2)  $T_A = +125^\circ\text{C}$ , minimum.
- b. Interim and final electrical test parameters shall be as specified in table II herein, except interim electrical parameter tests prior to burn-in are optional at the discretion of the manufacturer.

4.3 Quality conformance inspection. Quality conformance inspection shall be in accordance with method 5005 of MIL-STD-883 including groups A, B, C, and D inspections. The following additional criteria shall apply.

4.3.1 Group A inspection.

- a. Tests shall be as specified in table II herein.
- b. Subgroups 4, 5, and 6 in table I, method 5005 of MIL-STD-883 shall be omitted.
- c. Subgroups 7 and 8 tests shall verify the truth table as specified on figure 2.

4.3.2 Groups C and D inspections.

- a. End-point electrical parameters shall be as specified in table II herein.
- b. Steady-state life test conditions, method 1005 of MIL-STD-883.
  - (1) Test condition A, B, C, or D using the circuit submitted with the certificate of compliance (see 3.5 herein).
  - (2)  $T_A = +125^\circ\text{C}$ , minimum.
  - (3) Test duration: 1,000 hours, except as permitted by method 1005 of MIL-STD-883.

<b>STANDARDIZED MILITARY DRAWING</b> DEFENSE ELECTRONICS SUPPLY CENTER DAYTON, OHIO 45444	SIZE <b>A</b>	5962-87507
		REVISION LEVEL <b>A</b>

DESC FORM 193A  
SEP 87

\* U. S. GOVERNMENT PRINTING OFFICE: 1988-550-547



Case outlines	E	F	2
Terminal number	Terminal symbol		
1	VCC1	A3	NC
2	Y1	Y3	VCC1
3	Y1	Y3	Y1
4	A1	VCC2	Y1
5	B1	VCC1	A1
6	Y2	Y1	NC
7	Y2	Y1	B1
8	VEE	A1	Y2
9	A2	B1	Y2
10	B2	Y2	VEE
11	C2	Y2	NC
12	B3	VEE	A2
13	A3	A2	B2
14	Y3	B2	C2
15	Y3	C2	B3
16	VCC2	B3	NC
17	---	---	A3
18	---	---	Y3
19	---	---	Y3
20	---	---	VCC2

NC = No connection

FIGURE 1. Terminal connections.

<b>STANDARDIZED MILITARY DRAWING</b> DEFENSE ELECTRONICS SUPPLY CENTER DAYTON, OHIO 45444	SIZE <b>A</b>	5962-87507
	REVISION LEVEL A	SHEET 9

DESC FORM 193A  
SEP 87

\* U. S. GOVERNMENT PRINTING OFFICE: 1988-550-547

Inputs		Outputs	
A	B	Y	$\bar{Y}$
L	L	L	H
L	H	H	L
H	L	H	L
H	H	H	L

L = Low level  
H = High level

Inputs			Outputs	
A	B	C	Y	$\bar{Y}$
L	L	L	L	H
L	L	H	H	L
L	H	L	H	L
L	H	H	H	L
H	L	L	H	L
H	L	H	H	L
H	H	L	H	L
H	H	H	H	L

FIGURE 2. Truth tables.

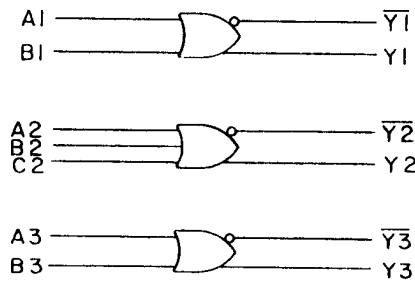
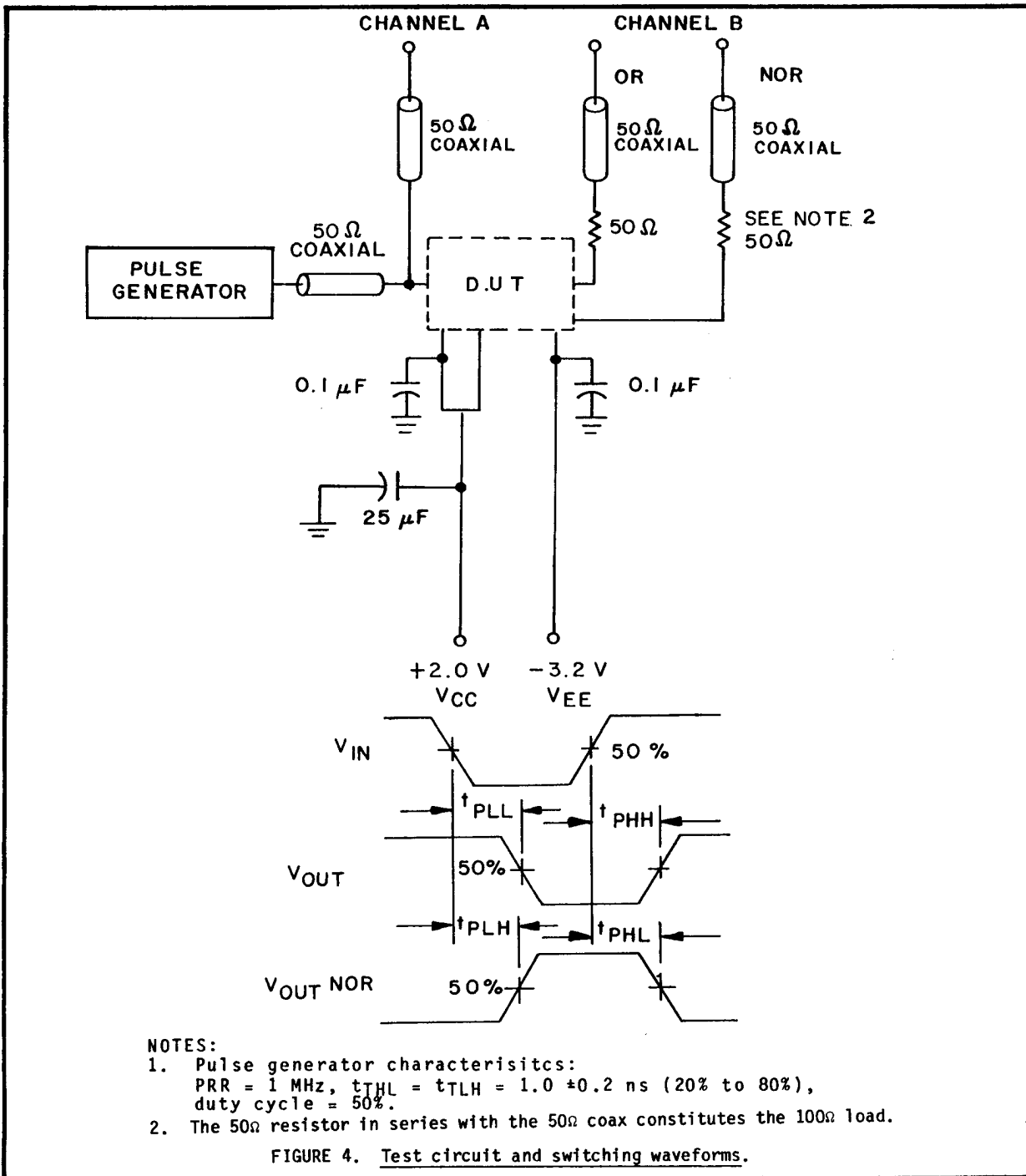

FIGURE 3. Logic diagram.

<b>STANDARDIZED MILITARY DRAWING</b> DEFENSE ELECTRONICS SUPPLY CENTER DAYTON, OHIO 45444	SIZE <b>A</b>	5962-87507
	REVISION LEVEL A	SHEET 10

DESC FORM 193A  
SEP 87

U. S. GOVERNMENT PRINTING OFFICE: 1988-550-547



<b>STANDARDIZED MILITARY DRAWING</b> DEFENSE ELECTRONICS SUPPLY CENTER DAYTON, OHIO 45444	<b>SIZE</b> <b>A</b>	5962-87507
	<b>REVISION LEVEL</b> A	<b>SHEET</b> 11

DESC FORM 193A  
SEP 87

U. S. GOVERNMENT PRINTING OFFICE: 1968-550-547

TABLE II. Electrical test requirements.

MIL-STD-883 test requirements	Subgroups (per method 5005, table I)
Interim electrical parameters (method 5004)	1
Final electrical test parameters (method 5004)	1*,2,3,7,8,9
Group A test requirements (method 5005)	1,2,3,7,8,9 10,11
Groups C and D end-point electrical parameters (method 5005)	1,2,3

\* PDA applies to subgroups 1.

5. PACKAGING

5.1 Packaging requirements. The requirements for packaging shall be in accordance with MIL-M-38510.

6. NOTES

6.1 Intended use. Microcircuits conforming to this drawing are intended for use when military specifications do not exist and qualified military devices that will perform the required function are not available for OEM application. When a military specification exists and the product covered by this drawing has been qualified for listing on QPL-38510, the device specified herein will be inactivated and will not be used for new design. The QPL-38510 product shall be the preferred item for all applications.

6.2 Replaceability. Microcircuits covered by this drawing will replace the same generic device covered by a contractor-prepared specification or drawing.

6.3 Comments. Comments on this drawing should be directed to DESC-ECS, Dayton, Ohio 45444, or telephone 513-296-5375.

<b>STANDARDIZED MILITARY DRAWING</b> DEFENSE ELECTRONICS SUPPLY CENTER DAYTON, OHIO 45444	SIZE <b>A</b>		5962-87507
		REVISION LEVEL A	SHEET 12

DESC FORM 193A  
SEP 87

\* U. S. GOVERNMENT PRINTING OFFICE: 1988-580-547

6.4 Approved source of supply. An approved source of supply is listed herein. Additional sources will be added as they become available. The vendor listed herein has agreed to this drawing and a certificate of compliance (see 3.5 herein) has been submitted to DESC-ECS.

Military drawing part number	Vendor CAGE number	Vendor similar part number <sup>1/</sup>
5962-8750701EX	04713	10H505/BEAJC
5962-8750701FX	04713	10H505/BFAJC
5962-87507012X	04713	10H505M/B2AJC

<sup>1/</sup> Caution. Do not use this number for item acquisition. Items acquired to this number may not satisfy the performance requirements of this drawing.

Vendor CAGE number

04713

Vendor name and address

Motorola, Incorporated  
7402 South Price Road  
Tempe, AZ 85283

<b>STANDARDIZED MILITARY DRAWING</b> DEFENSE ELECTRONICS SUPPLY CENTER DAYTON, OHIO 45444	SIZE <b>A</b>	5962-87507
	REVISION LEVEL A	SHEET 13

DESC FORM 193A  
SEP 87

U. S. GOVERNMENT PRINTING OFFICE: 1968-550-547