

Protection in Portable Electronics Applications.

FEATURES

- Transient protection for data lines to IEC 61000-4-2(ESD) 15kV(Air), 8kV(Contact)
- Small package for use in portable electronics.
- Suitable replacement for Multi-Layer Varistors in ESD protection applications.
- Protects one I/O or power line.
- Low clamping voltage.
- Low leakage current.

APPLICATIONS

- Cell phone handsets and accessories.
- Microprocessor based equipment.
- Personal digital assistants (PDA's)
- Notebooks, desktops, & servers.
- Portable instrumentation.
- Pagers peripherals.

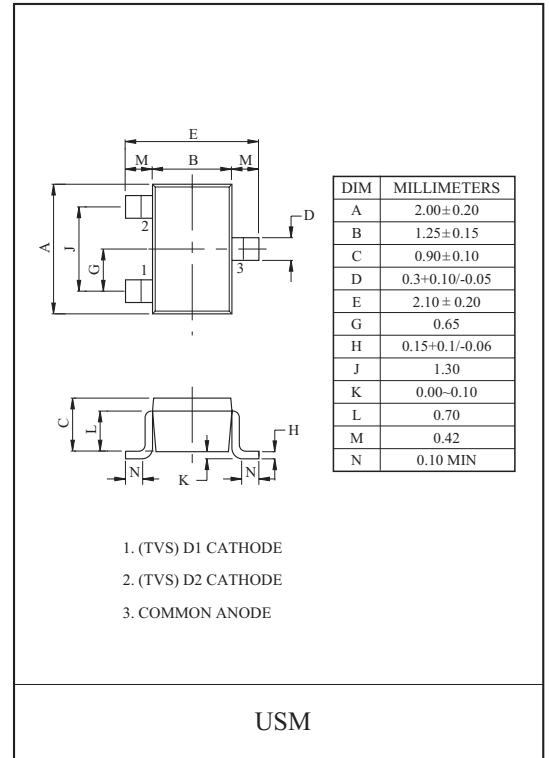

MAXIMUM RATING (Ta=25 °C)

CHARACTERISTIC	SYMBOL	RATING	UNIT
Total Power Dissipation	P _{PK}	200	mW
Junction Temperature	T _j	150	°C
Storage Temperature	T _{stg}	-55 ~ 150	°C

Marking

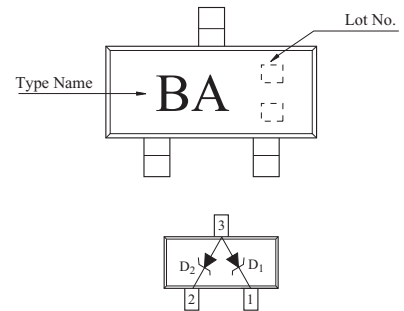

ELECTRICAL CHARACTERISTICS (Ta=25 °C)

CHARACTERISTIC	SYMBOL	TEST CONDITION	MIN.	TYP.	MAX.	UNIT
Reverse Stand-Off Voltage	V _{RWM}	-	-	-	5	V
Reverse Breakdown Voltage	V _{BR}	I _r =5mA	6.46	-	7.14	V
Reverse Leakage Current	I _R	V _{RWM} =5V	-	-	0.5	μA
Junction Capacitance	C _J	V _R =0V, f=1MHz	-	3	-	pF

PG05BAUSM

NON-REPETITIVE PEAK PULSE
POWER VS. PULSE TIME

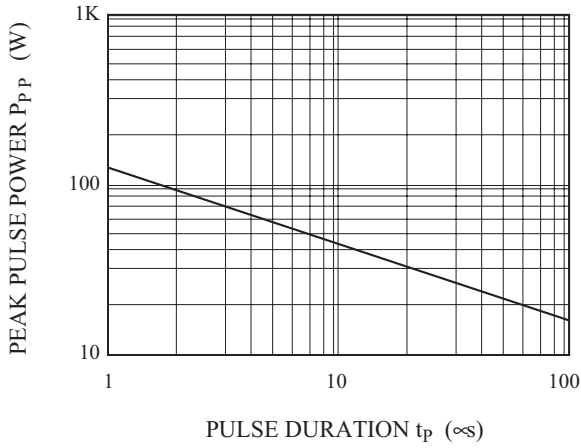

POWER DERATION CURVE

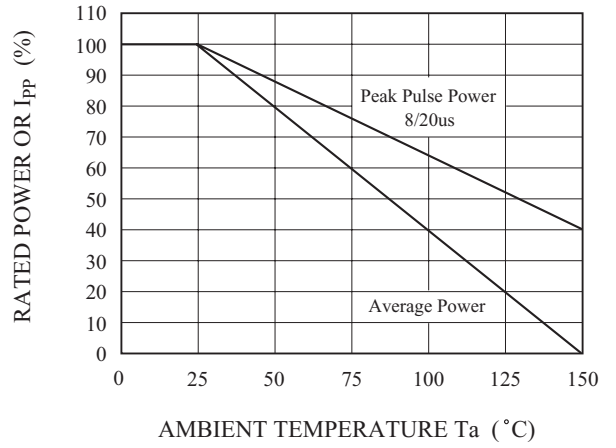

PULSE WAVEFORM

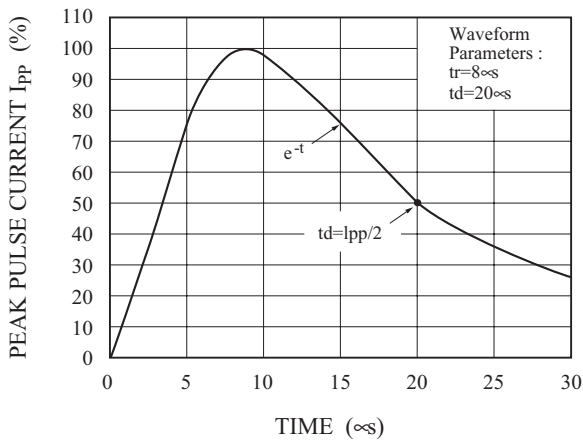

$C_J - V_R$

