

GSD

1964-1-5

REVISIONS

ISSUE	CHANGES
0	ER 33592 JCA 01/21/92
1	CN 36666 C KH 11/14/95

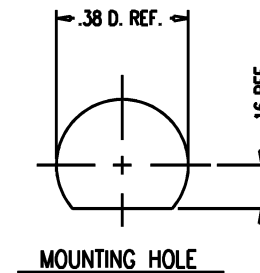
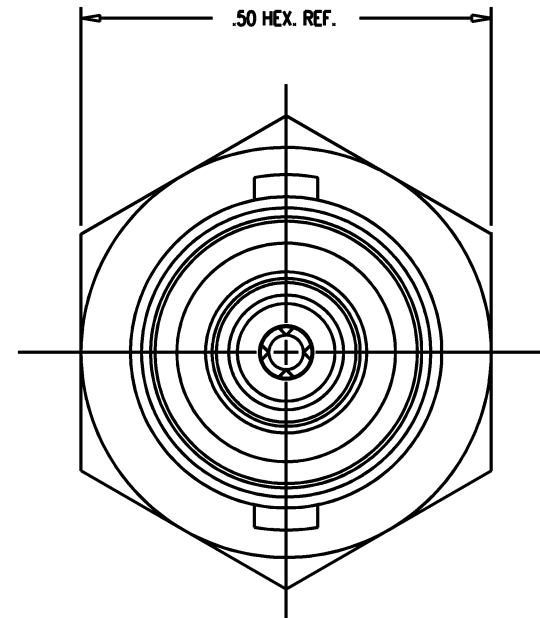
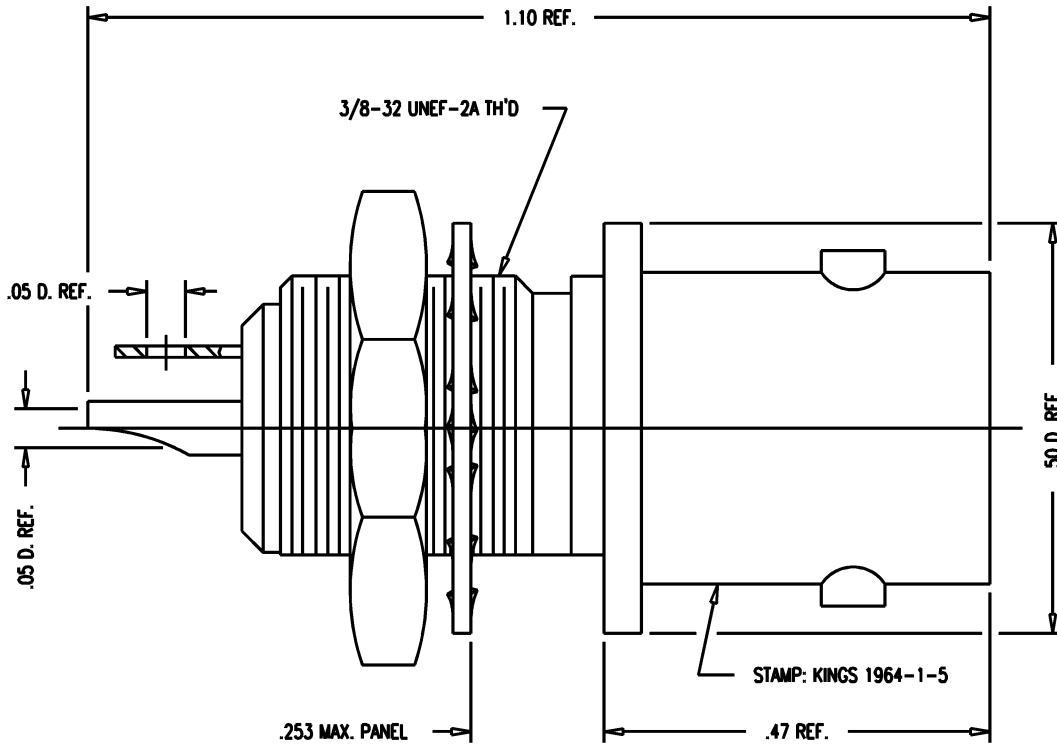

MOUNTING HOLE

NOTES:

1. INTERFACE PER MIL-STD-348, FIG. 201-2 (AS APPLICABLE).
2. MATERIALS:
INSULATORS: TEFLON, ASTM-D-4894
CENTER CONTACT: BER. COPPER, ASTM-B-196
LOCKWASHER: PHOSPHOR BRONZE, ASTM-B-103
ALL OTHER METAL PARTS: BRASS, ASTM-B16
3. FINISHES:
CENTER CONTACT } HARD GOLD PLATE, PER MIL-G-45204
INTER. CONTACT }
ALL OTHER METAL PARTS: SILVER PLATE PER QQ-S-365
4. ELECTRICAL CHARACTERISTICS:
WORKING VOLTAGE: 400 VRMS
FREQUENCY RANGE: DC TO 500 MHz

JCA2415

SCALE 6:1

APPROX SURFACE AREA

USED ON

REF: ROCKWELL 13499 357-0543-010 REV. E

RECEPTACLE, BULKHEAD, TRB

DRAWN JCA 01/21/92

DESIGN LJ 01/21/92

APPR. DATE

KINGS
ELECTRONICS CO., INC.
TUCKAHOE, NEW YORK 10707

1964-1-5

GSD