

CABLE ASSEMBLIES

USB 2.0 MOULDED LEADS

- PC and Mac compatible
- Fully compatible with USB 2.0 specification
- Transfer rates 40 times faster 480mbps than USB 1.1
- Various cable lengths available



SPECIFICATION

Conductor Material:	Tinned Copper
Wire Gauge:	Varies depending on cable length
Shield Material:	Tinned Copper, coverage 65% minimum
Jacket Material:	PVC
Jacket Thickness:	0.23mm min average
Jacket Outer Dimension:	5.20 ±0.15mm

OUTLINE DRAWING

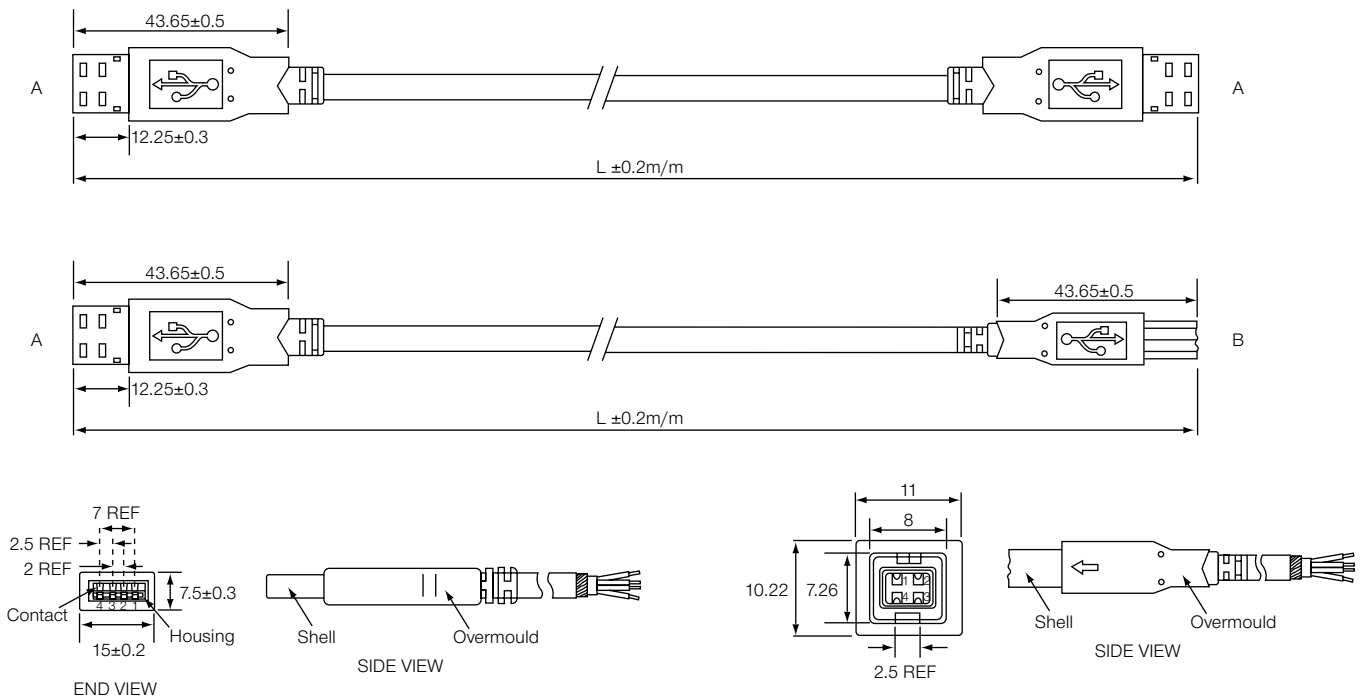

ORDERING INFORMATION

DBC	USB2	AA	3M
Dubilier Connectors	USB	Style AA = A-A Style AB = A-B Style	Cable Length 0.5M = 0.5 metres 1M = 1 metre 1.5M = 1.5 metres 2M = 2 metres 2.5M = 2.5 metres 3M = 3 metres 4M = 4 metres 5M = 5metres

SECTION 9