

NEW

0.3 mm Pitch, 0.65 mm above the board, Top Contact, Back-Flip actuator Flexible Printed Circuit ZIF Connectors

FH42 Series

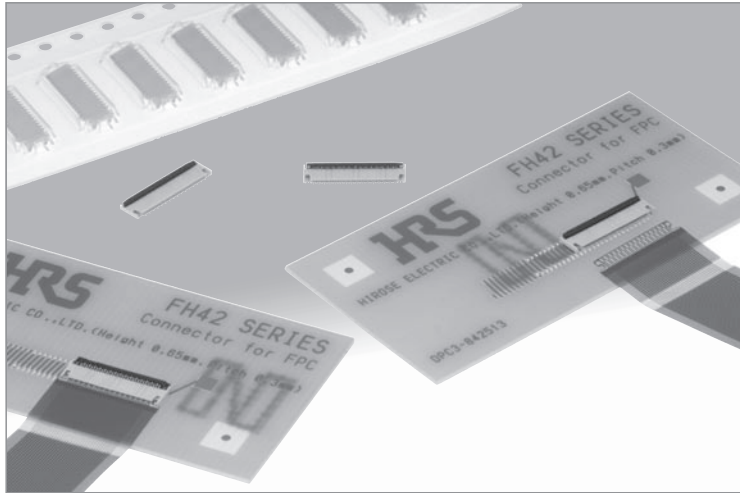

Height 0.65mm

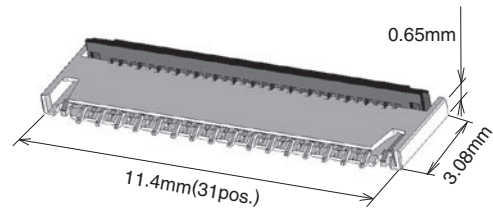

Figure. 1

■Features

1. Low-profile and space-saving 0.3mm pitch, top contact point, connector

A top contact point type connector, low-profile and space-saving design, with 0.65mm height and 3.55mm depth (implementation depth: 3.08mm).

2. FPC retention secured, despite the low profile

Improved FPC horizontal retention by reinforcing the clasp temporary retention mechanism.

3. Delivered with the actuator open

FPC can be immediately inserted without the need for the opening of the actuator.

4. Favorable FPC insertion, despite the low profile

- The unique clasp form means an audible click when the FPC goes over the clasp, while also preventing incorrect (diagonal) insertion of FPC.
- Despite the temporary retention mechanism of the reinforcing clasp, horizontal insertion of FPC is possible.

5. Accepts standard FPC thickness

0.12mm thick standard Flexible Printed Circuit (FPC) can be used. This is the only ultra-low profile ZIF connector using standard FPC.

6. Conductive traces on the PCB can run under the connector

No exposed contacts on the bottom of the connector.

7. Board placement with automatic equipment

Flat upper surface and tape and reel packaging facilitate vacuum pick-up and placement. Standard reel packaging contains 5,000 connectors.

8. Halogen-free *

*As defined by IEC61249-2-21
 Br-900ppm maximum, Cl-900ppm maximum,
 Cl + Br combined-1,500ppm maximum

Simple FPC insertion

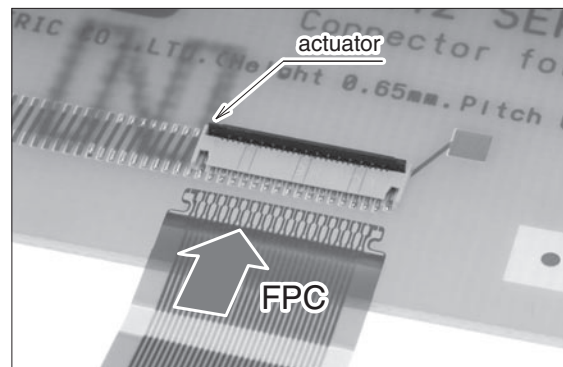

Figure. 2

Lock

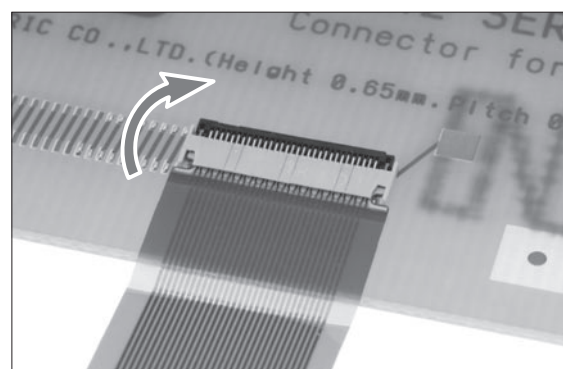

Figure. 3

FH42 Series 0.3 mm Pitch, 0.65 mm above the board, Top Contact, Back-Flip actuator Flexible Printed Circuit ZIF Connectors

■ Specifications

Ratings	Current rating 0.2 A(Note1)	Operating temperature range:-55 to +85°C (Note 2)	Storage temperature range:-10 to +50°C (Note 3)
	Voltage rating 30 Vrms AC	Operating humidity range:Relative humidity 90% max. (No condensation)	Storage humidity range:Relative humidity 90% max. (No condensation)

Recommended FPC Thickness	0.12 +/- 0.02 mm, Gold plated contact pads
---------------------------	--

Item	Specification	Conditions
1.Insulation resistance	50 MΩ min.	100 V DC
2.Withstanding voltage	No flashover or insulation breakdown	90 Vrms AC / one minute
3.Contact resistance	200 mΩ max. * Including FPC and FFC conductor resistance	1 mA, AC max (AC: 1kHz)
4.Durability	Contact resistance: 200 mΩ max. No damage, cracks, or parts dislocation	10 cycles
5.Vibration	No electrical discontinuity of 1μs or longer Contact resistance: 200 mΩ max. No damage, cracks, or parts dislocation	Frequency: 10 to 55 Hz, single amplitude of 0.75mm, 10 cycles in each of the 3 axis
6.Shock	No electrical discontinuity of 1μs or longer Contact resistance: 200 mΩ max. No damage, cracks, or parts dislocation	Acceleration of 981m/s ² , 6 ms duration, sine halfwave, 3 cycles in each of the 3 axis
7.Humidity (Steady state)	Contact resistance: 200 mΩ max. Insulation resistance: 50 MΩ min. No damage, cracks, or parts dislocation	96 hours at 40°C and humidity of 90 to 95%
8.Temperature cycle	Contact resistance: 200 mΩ max. Insulation resistance: 50 MΩ min. No damage, cracks, or parts dislocation	Temperature : -55°C → +15°C to +35°C → +85°C → +15°C to +35°C Time: 30 → 2 to 3 → 30 → 2 to 3 minutes 5 cycles
9.Resistance to soldering heat	No deformation of components affecting performance	Reflow: At the recommended temperature profile Manual soldering: 350°C ±10°C for 5 seconds

Note 1: When passing the current through all of the contacts, use 70% of the rated current.

Note 2: Includes temperature rise caused by current flow.

Note 3: The term "storage" refers to products stored for a long period prior to mounting and use.

The operating temperature and humidity range covers the non-conducting condition of installed connectors in storage, shipment or during transportation after board mounting.

Note 4: Information contained in this catalog represents general requirements for this Series.

Contact us for the drawings and specifications for a specific part number shown.

■ Materials

Part	Material	Finish	Remarks
Insulator	LCP	Color:Beige	UL94V-0
	PA	Color:Black	UL94HB
Contacts	Phosphor bronze	Gold plated	—
Metalfittings		Pure tin reflow plated	—

■ Ordering information

FH 42 - 31S - 0.3 SHW (10)

① ② ③ ④ ⑤ ⑥

① Series name : FH	⑤ Contact type SHW : SMT horizontal staggered mounting
② Series No. : 41	
③ Number of positions : 19,31,41	⑥ Plating specifications (10)...Gold plating with nickel barrier
④ Contact pitch : 0.3mm	

■ Connector Dimensions

[FH42 Series]

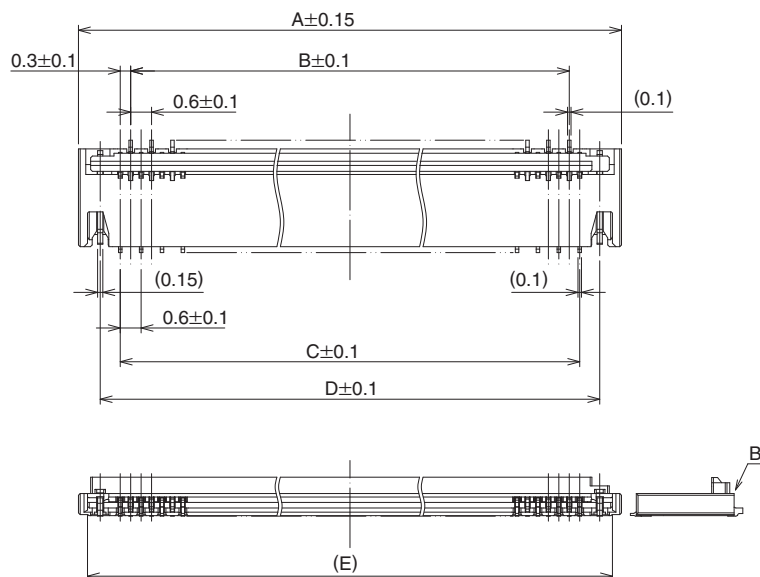

Detail drawing

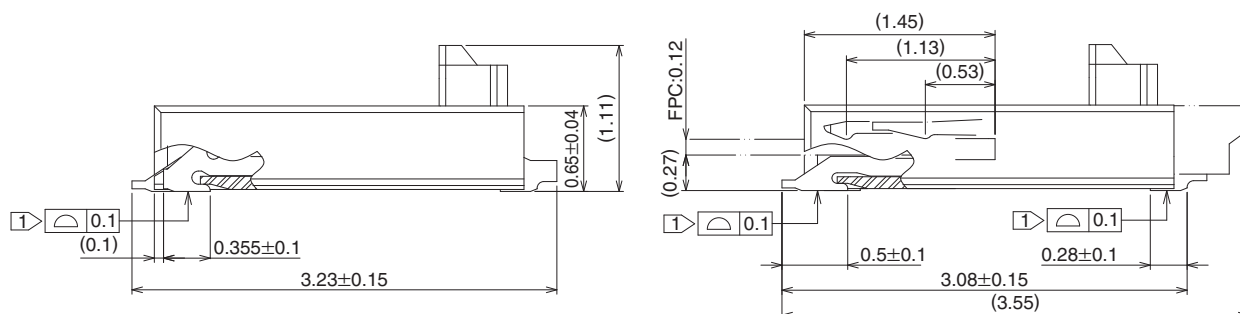

- Note 1. The coplanarity of each terminal lead within specified dimension is 0.1 mm Max.
 2. Packaged on tape and reel only. Check packaging specification.
 3. Slight variations in color of the plastic compounds do not affect form, fit or function of the connector.
 4. After reflow, the terminal plating may change color, however this does not represent a quality issue.

Unit : mm

Part Number	CL No.	Number of contacts	A	B	C	D	E
FH42-19S-0.3SHW(10)	0580-2305-8-10	19	7.8	4.8	5.4	6.55	7.28
FH42-31S-0.3SHW(10)	0580-2301-7-10	31	11.4	8.4	9	10.15	10.88
FH42-41S-0.3SHW(10)	0580-2304-5-10	41	14.4	11.4	12	13.15	13.88

Note1. Tape and reel packaging (5,000 pieces/reel). Order by number of reels.

■ Recommended FPC construction

1. Using Single-sided FPC

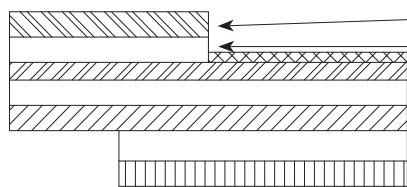

FPC : Flexible Printed Circuit

Material Name	Material	Material Thickness (μm)
Covering film layer	Polyimide 1 mil thick.	(25)
Cover adhesive		(25)
Surface treatment	0.2μm thick gold plated over 1 to 5μm nickel underplating	3.2
Copper foil	Cu 1/2 oz	18
Base adhesive	Thermosetting adhesive	Non-adhesive type
Base film	Polyimide 1 mil thick	25
Reinforcement material adhesive	Thermosetting adhesive	35
Stiffener	Polyimide 2 mil thick	40
Total		131.2

2. Precautions

1. This specification is a recommendation for the construction of the FH42 Series FPC and FFC ($t=0.12 \pm 0.02$).
2. For details about the construction, please contact the FPC/FFC manufacturers.

■ Packaging Specification

● Embossed Carrier Tape Dimensions (Tape width to 24mm max.)

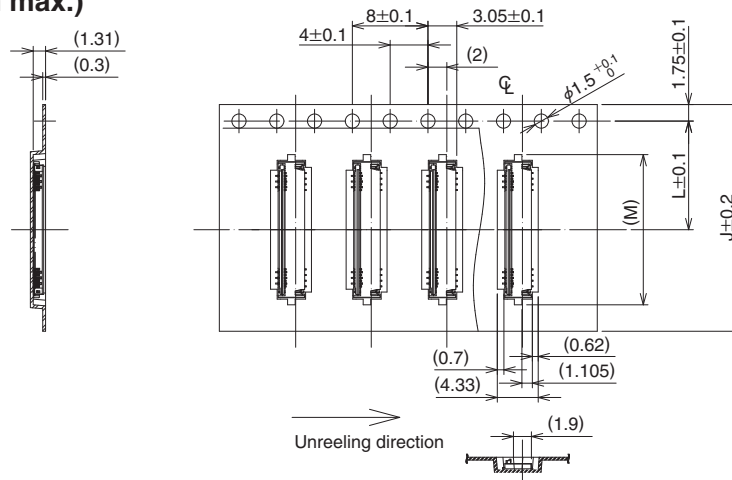

● Embossed Carrier Tape Dimensions (Tape width 32mm min.)

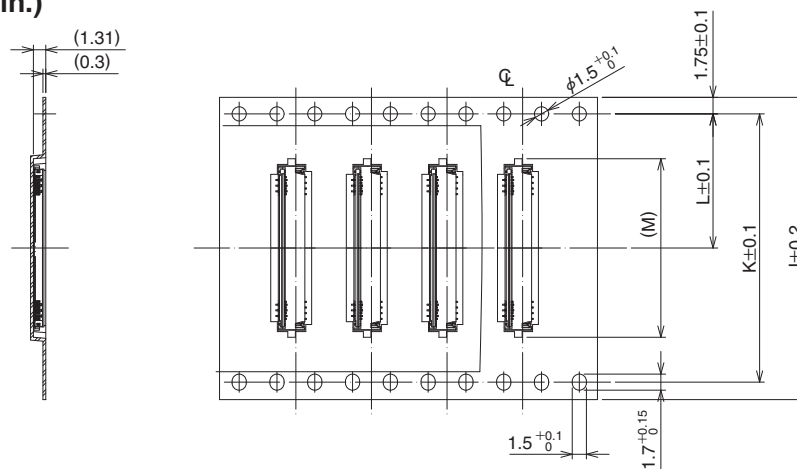

● Reel Dimensions

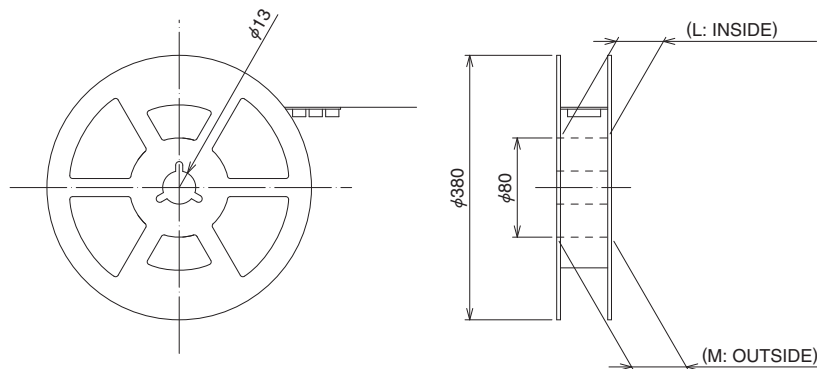

Unit : mm

Part Number	CL No.	Number of contacts	J	K	L	M	N	P
FH42-19S-0.3SHW(10)	0580-2305-8-10	19	24	—	11.5	9.3	25.4	29.4
FH42-31S-0.3SHW(10)	0580-2301-7-10	31	24	—	11.5	12.9	25.4	29.4
FH42-41S-0.3SHW(10)	0580-2304-5-10	41	24	—	11.5	15.9	25.4	29.4

Tape and reel packaging (5,000 pieces/reel).

■ Temperature Profile

● Using Lead-free Solder Paste

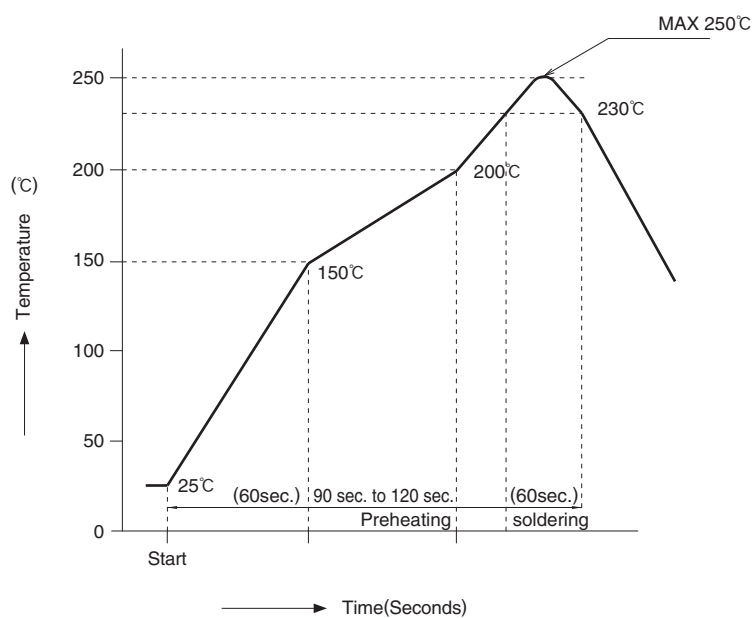

HRS test condition

Solder method	:Reflow, IR/hot air
Environment	:Room air
Solder composition	:Paste, 96.5%Sn/3.0%Ag/0.5%Cu (Senju Metal Industry, Co., Ltd.'s Part Number:M705-GRN360-K2-V)
Test board	:Glass epoxy 25mm×50mm×0.8mm thick
Land dimensions	:0.28mm×0.6mm,0.28mm×0.9mm
Metal mask	:0.26×0.48,0.26×0.73×0.1mm thick

The temperature profiles shown are based on the above conditions.

In individual applications the actual temperature may vary, depending on solder paste type, volume / thickness and board size / thickness. Consult your solder paste and equipment manufacturer for specific recommendations.

■ Connector Operation and Precautions

Operation

Exercise care when handling connectors. Follow recommendations given below.

1. As delivered

- 1 Delivered with the actuator open. There is no need to operate the actuator prior to the insertion of the FPC.

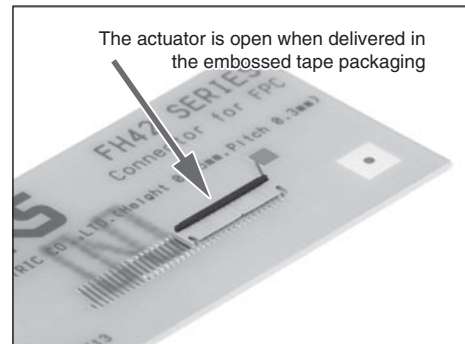

2. FPC insertion (Top contact)

- 1 Make sure that the conductive pads are facing up.
- 2 Align the FPC perpendicular with the connector and insert it firmly all the way.

*For the bottom contact, reverse.

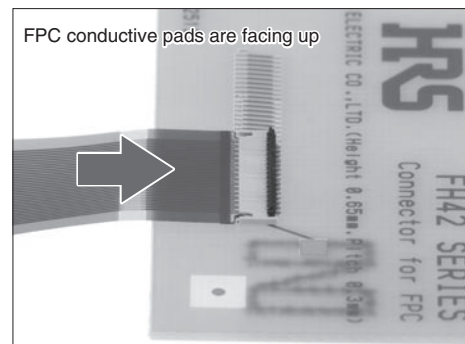

3. FPC correct insertion verification (Top contact)

A visual comparison of the edge of the housing opening and the FPC pattern boundary will prevent diagonal insertion and partial insertion errors.

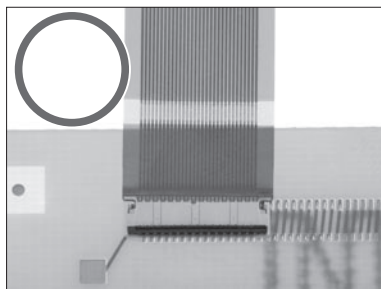
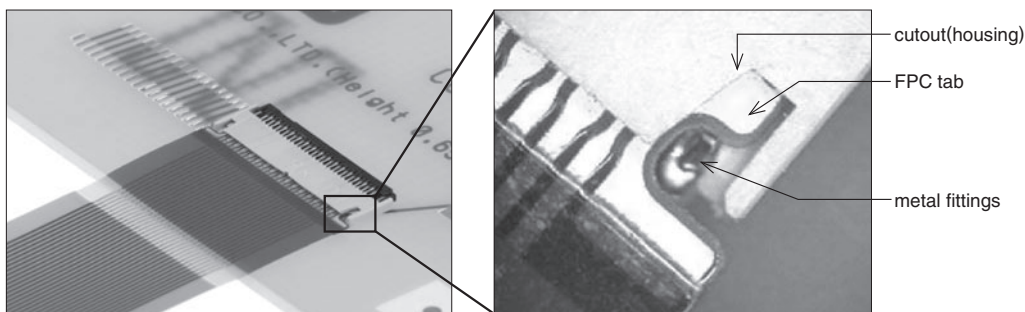

Correct insertion

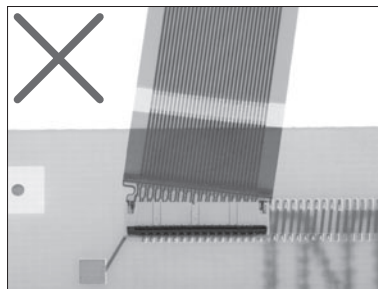

Diagonal insertion

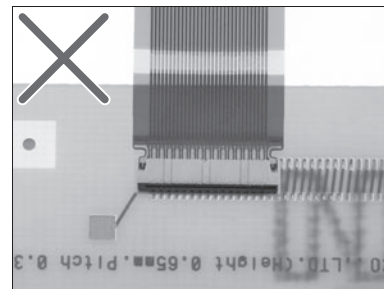

Partial insertion

Operation

4. Locking

① After FPC/FFC insertion, rotate the actuator down to a full stop, pushing it at the center.

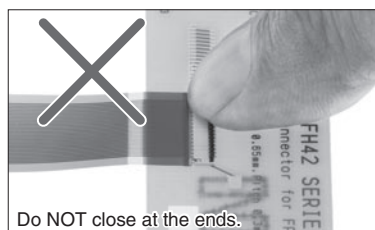
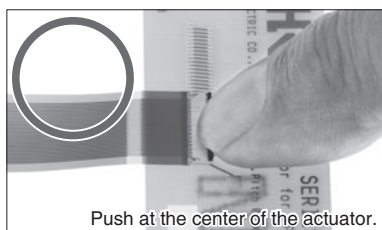
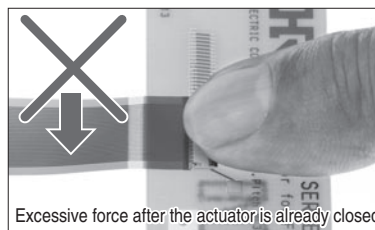
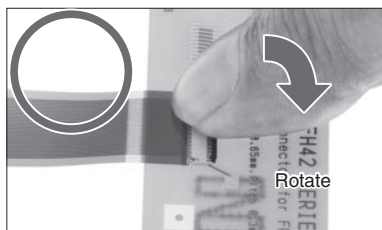

5. FPC removal (Lock release)

Carefully rotate the actuator up to 90°, lifting it at the center.

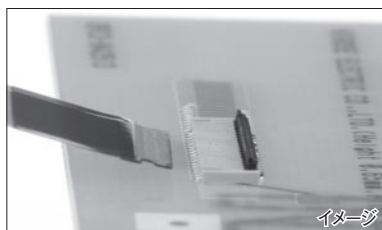
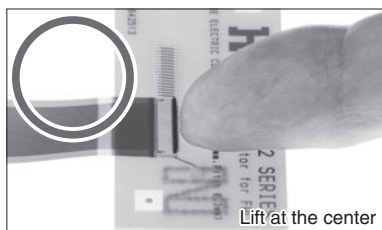
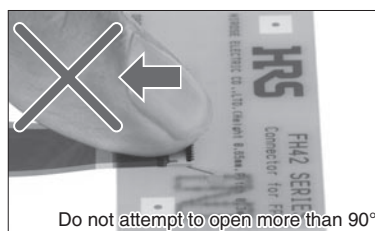
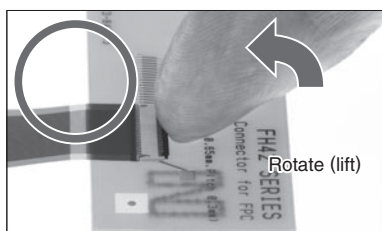

* The actuator opens by rotating it in the direction OPPOSITE to the direction of the insertion of the FPC.
 DO NOT attempt to open it from the same side as the insertion of the FPC.

Precautions when mounting connectors on the PCB

◆ Handling before mounting on PCB

Insertion of the FPC or operation of the actuator prior to mounting on the PCB is NOT RECOMMENDED.

◆ PC board warpage

Minimize the warpage as much as possible. The connector is straight within 0.1 mm max. Make sure that the mounting area flatness can accept the connector terminals without causing any failure of the solder joints.

◆ Forces on the board

◆ When braking the large PC board into individual boards exercise care NOT to damage the installed connectors.

◆ When attaching the boards or other components with the screws make sure that any stresses will NOT cause board deflections affecting the mounting areas of the connector

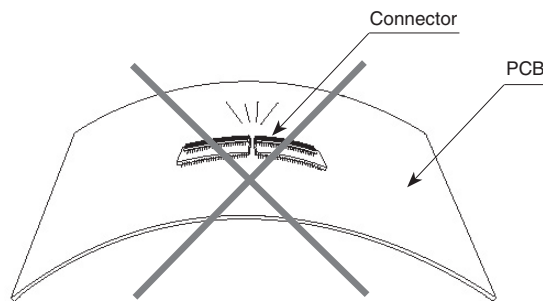

Other precautions

◆ When hand soldering:

Do not perform hand soldering with the FPC inserted in the connector.

- Do not apply excessive heat or touch the soldering iron anywhere other than the connector leads.
- Do not use excessive amount of solder or flux compounds.

Operation of the actuator or contacts may be affected by excessive amounts of solder or flux compounds.