

VF75

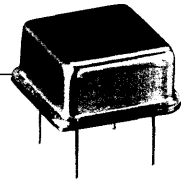

TTL Compatible Half Size DIP Clock Oscillators

FEATURES

- Wide Frequency Range
- Extended Temperature Ranges
- Tight Symmetry Available
- Common Footprint
- Tristate Available

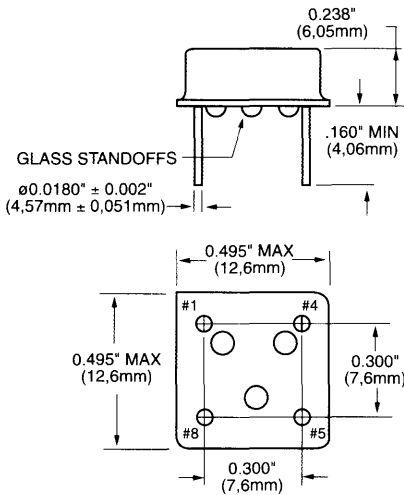

All dimensions are typical unless otherwise specified.

Creating a Part Number

VF75 [] - [] - **FREQ.**

FREQUENCY STABILITY	
Code	Specification
S	±20 ppm
A	±25 ppm
B	±50 ppm
	±100 ppm (std.)
C	±500 ppm

LEAD CONFIGURATION	
Code	Specification
GR	Gull Wing
G	Gull Wing
	Through Hole (std.)

DUTY CYCLE	
Code	Specification
H	±5%
	±10% (std.)

OUTPUT	
Code	Specification
T	Tristate
	Non-tristate (std.)

INPUT VOLTAGE	
Code	Specification
L	3.3 Volt ±5%
	5.0 Volt ±5% (std.)

OPERATIONAL TEMP. RANGE	
Code	Specification
	0°C to +70°C (std.)
1	-40°C to +85°C
2	-55°C to +125°C*

*Not always available

Example: VF75A-2G-25MHz: Frequency Stability ±25ppm, Duty Cycle ±10%, Input Voltage 5.0 Volt ±5%, Operating Temperature -55°C to +125°C, Output Non-Tristate, Lead Configuration Gull Wing, Frequency 25MHz.

	Parameter	Symb	Condition	Min	Typ	Max	Unit	Note
Absolute Max. Ratings	Input Break Down Voltage	V _{cc}		-0.5		7.0	V	
	Storage Temp.	T _s		-55		+125	°C	
Electrical	Frequency	F		0.25		100	MHz	
	Frequency Stability	ΔF/F	Overall conditions including: calibration, temp., aging 10 yrs, shock, vibration			±100	ppm	1
	Input Voltage	V _{cc}		4.75 3.15	5.00 3.30	5.25 3.45	V	Std. LV Opt.
	Input Current	I _{cc}	No load			60	mA	2
	Load			10 TTL gates				
	Duty Cycle		@1.4V	40	50	60	%	3
	Rise/Fall Time	T _r /T _f				6	ns	f>60MHz
	Logic "1" Level	V _{oh}	MAX Load	2.4			V	
	Logic "0" Level	V _{ol}	MAX Load			0.4	V	
	Start-up Time	T _s			2	10	ms	
Phase Jitter		1σ			1	ps	f>1KHz	
Tristate Function			Input HIGH (>2.5V) or floating: ACTIVE Input LOW (<0.5V): INFINITE IMPEDANCE					
Enable/Disable Time	T _e /T _d				100	ns	4	
Environmental and Mechanical	Operating Temperature Range	0°C to +70°C (-40°C to +85°C, and -55°C to +125°C available)						
	Mechanical Shock	Per MIL-STD-202, Method 213, Cond. E						
	Thermal Shock	Per MIL-STD-883, Method 1011, Cond. A						
	Vibration	Per MIL-STD-883, Method 2007, Cond. A						
	Soldering Conditions	260°C, for 10s, Max.						
Hermetic Seal	Leak rate less than 5 x 10 ⁻⁸ atm.cc/s of helium							
Electrical Connections	Pin Out	Pin #1-NC or Tristate Control Pin #5-Output		Pin #4-Ground, Case Pin #8-V _{cc}				

Notes:

1. Standard frequency stability (±20, ±25, ±50, others available).
2. Current is load and frequency dependent.
3. ±5%, duty cycle available.
4. Tristate available.

All specifications are subject to change without notice.