

QUAD D-TYPE FLIP-FLOP; POSITIVE-EDGE TRIGGER; 3-STATE

FEATURES

- Gated input enable for hold (do nothing) mode
- Gated output enable control
- Edge-triggered D-type register
- Asynchronous master reset
- Output capability: bus driver
- I^{CC} category: MSI

GENERAL DESCRIPTION

The 74HC/HCT173 are high-speed Si-gate CMOS devices and are pin compatible with low power Schottky TTL (LSTTL). They are specified in compliance with JEDEC standard no. 7A.

The 74HC/HCT173 are 4-bit parallel load registers with clock enable control, 3-state buffered outputs (Q₀ to Q₃) and master reset (MR).

When the two data enable inputs (\bar{E}_1 and \bar{E}_2) are LOW, the data on the D_n inputs is loaded into the register synchronously with the LOW-to-HIGH clock (CP) transition. When one or both \bar{E}_n inputs are HIGH one set-up time prior to the LOW-to-HIGH clock transition, the register will retain the previous data. Data inputs and clock enable inputs are fully edge-triggered and must be stable only one set-up time prior to the LOW-to-HIGH clock transition.

The master reset input (MR) is an active HIGH asynchronous input. When MR is HIGH, all four flip-flops are reset (cleared) independently of any other input condition.

The 3-state output buffers are controlled by a 2-input NOR gate. When both output enable inputs (\bar{OE}_1 and \bar{OE}_2) are LOW, the data in the register is presented to the Q_n outputs. When one or both \bar{OE}_n inputs are HIGH, the outputs are forced to a high impedance OFF-state. The 3-state output buffers are completely independent of the register operation; the \bar{OE}_n transition does not affect the clock and reset operations.

SYMBOL	PARAMETER	CONDITIONS	TYPICAL		UNIT
			HC	HCT	
t _{PHL} / t _{PLH}	propagation delay CP to Q _n MR to Q _n	C _L = 15 pF V _{CC} = 5 V	17	17	ns
			13	17	ns
f _{max}	maximum clock frequency		88	88	MHz
C _I	input capacitance		3.5	3.5	pF
C _{PD}	power dissipation capacitance per flip-flop	notes 1 and 2	20	20	pF

GND = 0 V; T_{amb} = 25 °C; t_r = t_f = 6 ns

Notes

1. C_{PD} is used to determine the dynamic power dissipation (P_D in μW):

$$P_D = C_{PD} \times V_{CC}^2 \times f_i + \sum (C_L \times V_{CC}^2 \times f_o) \text{ where:}$$

f_i = input frequency in MHz C_L = output load capacitance in pF

f_o = output frequency in MHz

V_{CC} = supply voltage in V

∑ (C_L × V_{CC}² × f_o) = sum of outputs

2. For HC the condition is V_I = GND to V_{CC}
For HCT the condition is V_I = GND to V_{CC} - 1.5 V

PACKAGE OUTLINES

SEE PACKAGE INFORMATION SECTION

PIN DESCRIPTION

PIN NO.	SYMBOL	NAME AND FUNCTION
1, 2	\bar{OE}_1, \bar{OE}_2	output enable input (active LOW)
3, 4, 5, 6	Q ₀ to Q ₃	3-state flip-flop outputs
7	CP	clock input (LOW-to-HIGH, edge-triggered)
8	GND	ground (0 V)
9, 10	\bar{E}_1, \bar{E}_2	data enable inputs (active LOW)
14, 13, 12, 11	D ₀ to D ₃	data inputs
15	MR	asynchronous master reset (active HIGH)
16	V _{CC}	positive supply voltage

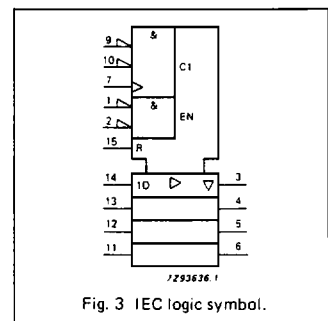
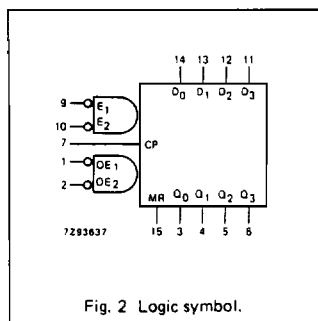
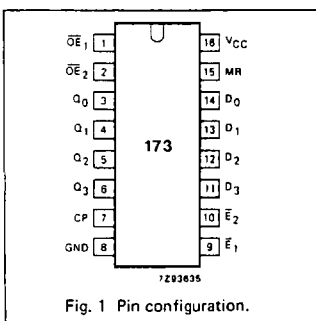

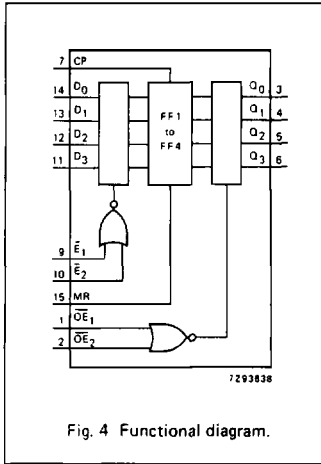

Fig. 4 Functional diagram.

FUNCTION TABLE

REGISTER OPERATING MODES	INPUTS					OUTPUTS
	MR	CP	E ₁	E ₂	D _n	Q _n (register)
reset (clear)	H	X	X	X	X	L
parallel load	L	↑	l	l	l	L
	L	↑	l	l	h	H
hold (no change)	L	X	h	X	X	q _n
	L	X	X	h	X	q _n

3-STATE BUFFER OPERATING MODES	INPUTS			OUTPUTS			
	Q _n (register)	OE ₁	OE ₂	Q ₀	Q ₁	Q ₂	Q ₃
read	L	L	L	L	L	L	L
	H	L	L	H	H	H	H
disabled	X	H	X	Z	Z	Z	Z
	X	X	H	Z	Z	Z	Z

H = HIGH voltage level
h = HIGH voltage level one set-up time prior to the LOW-to-HIGH CP transition
L = LOW voltage level
l = LOW voltage level one set-up time prior to the LOW-to-HIGH CP transition
q = lower case letters indicate the state of the referenced input (or output) one set-up time prior to the LOW-to-HIGH CP transition
X = don't care
Z = high impedance OFF-state
↑ = LOW-to-HIGH CP transition

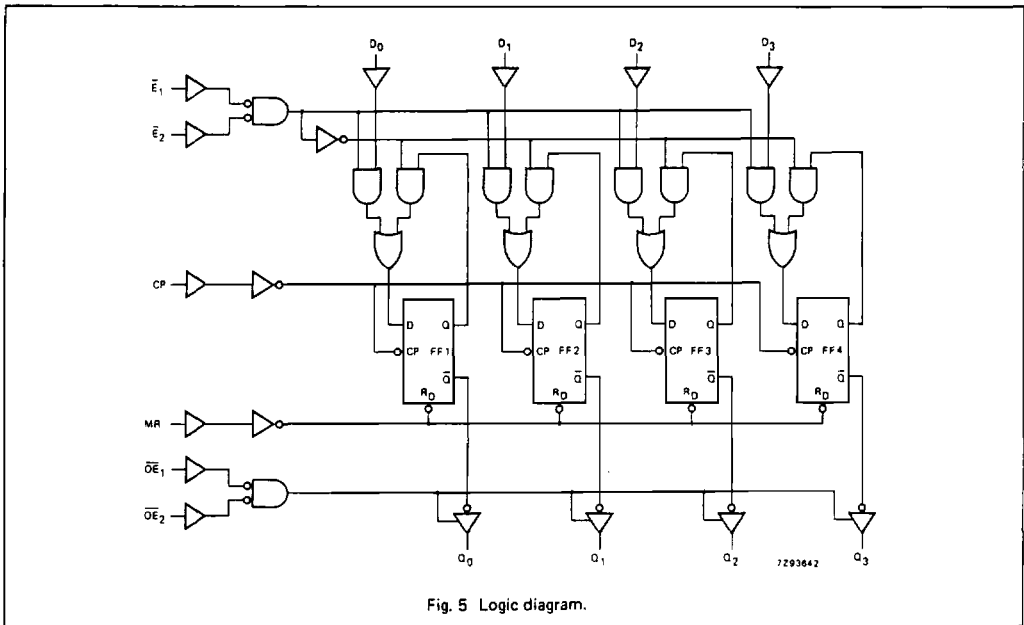

Fig. 5 Logic diagram.

DC CHARACTERISTICS FOR 74HC

For the DC characteristics see chapter "HCMOS family characteristics", section "Family specifications".

Output capability: bus driver

I_{CC} category: MSI

AC CHARACTERISTICS FOR 74HC

GND = 0 V; t_r = t_f = 6 ns; C_L = 50 pF

SYMBOL	PARAMETER	T _{amb} (°C)						UNIT	TEST CONDITIONS		
		74HC							V _{CC} V	WAVEFORMS	
		+25		-40 to +85		-40 to +125					
		min.	typ.	max.	min.	max.	min.				max.
t _{PHL} / t _{PLH}	propagation delay CP to Q _n		55 20 16	175 35 30		220 44 37		265 53 45	ns	2.0 4.5 6.0	Fig. 6
t _{PHL}	propagation delay MR to Q _n		44 16 13	150 30 26		190 38 33		225 45 38	ns	2.0 4.5 6.0	Fig. 7
t _{PZH} / t _{PZL}	3-state output enable time OE _n to Q _n		52 19 15	150 30 26		190 38 33		225 45 38	ns	2.0 4.5 6.0	Fig. 8
t _{PHZ} / t _{PLZ}	3-state output disable time OE _n to Q _n		52 19 15	150 30 26		190 38 33		225 45 38	ns	2.0 4.5 6.0	Fig. 8
t _{THL} / t _{TLH}	output transition time		14 5 4	60 12 10		75 15 13		90 18 15	ns	2.0 4.5 6.0	Fig. 6
t _w	clock pulse width HIGH or LOW	80 16 14	14 5 4		100 20 17		120 24 20		ns	2.0 4.5 6.0	Fig. 6
t _w	master reset pulse width: HIGH	80 16 14	14 5 4		100 20 17		120 24 20		ns	2.0 4.5 6.0	Fig. 7
t _{rem}	removal time MR to CP	60 12 10	-8 -3 -2		75 15 13		90 18 15		ns	2.0 4.5 6.0	Fig. 7
t _{su}	set-up time E _n to CP	100 20 17	33 12 10		125 25 21		150 30 26		ns	2.0 4.5 6.0	Fig. 9
t _{su}	set-up time D _n to CP	60 12 10	17 6 5		75 15 13		90 18 15		ns	2.0 4.5 6.0	Fig. 9
t _h	hold time E _n to CP	0 0 0	-17 -6 -5		0 0 0		0 0 0		ns	2.0 4.5 6.0	Fig. 9
t _h	hold time D _n to CP	1 1 1	-11 -4 -3		1 1 1		1 1 1		ns	2.0 4.5 6.0	Fig. 9
f _{max}	maximum clock pulse frequency	6.0 30 35	26 80 95		4.8 24 28		4.0 20 24		MHz	2.0 4.5 6.0	Fig. 6

DC CHARACTERISTICS FOR 74HCT

For the DC characteristics see chapter "HCMOS family characteristics", section "Family specifications".

Output capability: bus driver

I_{CC} category: MSI

Note to HCT types

The value of additional quiescent supply current (ΔI_{CC}) for a unit load of 1 is given in the family specifications. To determine ΔI_{CC} per input, multiply this value by the unit load coefficient shown in the table below.

INPUT	UNIT LOAD COEFFICIENT
$\overline{OE}_1, \overline{OE}_2$	0.50
MR	0.60
$\overline{E}_1, \overline{E}_2$	0.40
D _n	0.25
CP	1.00

AC CHARACTERISTICS FOR 74HCT

GND = 0 V; t_r = t_f = 6 ns; C_L = 50 pF

SYMBOL	PARAMETER	T _{amb} (°C)						UNIT	TEST CONDITIONS		
		74HCT							V _{CC} V	WAVEFORMS	
		+25			-40 to +85		-40 to +125				
		min.	typ.	max.	min.	max.	min.				max.
t _{PHL} / t _{PLH}	propagation delay CP to Q _n		20	40		50		60	ns	4.5	Fig. 6
t _{PHL}	propagation delay MR to Q _n		20	37		46		56	ns	4.5	Fig. 7
t _{PZH} / t _{PZL}	3-state output enable time \overline{OE}_n to Q _n		20	35		44		53	ns	4.5	Fig. 8
t _{PHZ} / t _{PLZ}	3-state output disable time \overline{OE}_n to Q _n		19	30		38		45	ns	4.5	Fig. 8
t _{THL} / t _{TLH}	output transition time		5	12		15		19	ns	4.5	Fig. 6
t _w	clock pulse width HIGH or LOW	16	7		20		24		ns	4.5	Fig. 6
t _w	master reset pulse width; HIGH	15	6		19		22		ns	4.5	Fig. 7
t _{rem}	removal time MR to CP	12	-2		15		18		ns	4.5	Fig. 7
t _{su}	set-up time \overline{E}_n to CP	22	13		28		33		ns	4.5	Fig. 9
t _{su}	set-up time D _n to CP	12	7		15		18		ns	4.5	Fig. 9
t _h	hold time \overline{E}_n to CP	0	-6		0		0		ns	4.5	Fig. 9
t _h	hold time D _n to CP	0	-3		0		0		ns	4.5	Fig. 9
f _{max}	maximum clock pulse frequency	30	80		24		20		MHz	4.5	Fig. 6

AC WAVEFORMS

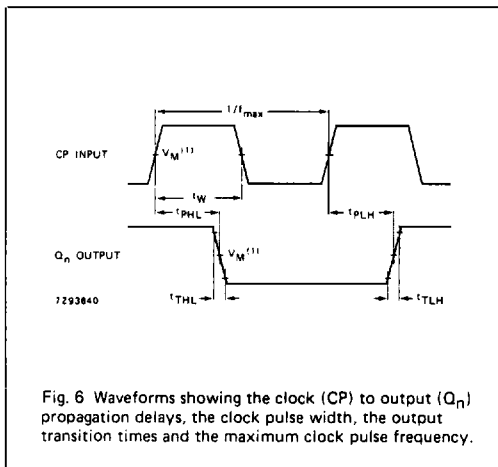

Fig. 6 Waveforms showing the clock (CP) to output (Q_n) propagation delays, the clock pulse width, the output transition times and the maximum clock pulse frequency.

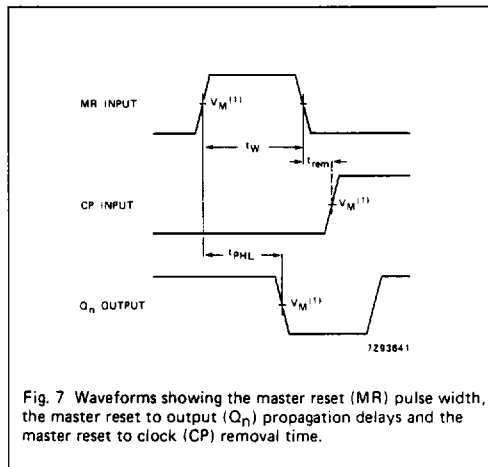

Fig. 7 Waveforms showing the master reset (MR) pulse width, the master reset to output (Q_n) propagation delays and the master reset to clock (CP) removal time.

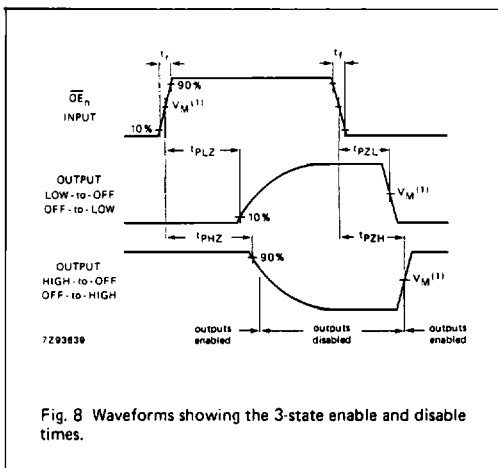

Fig. 8 Waveforms showing the 3-state enable and disable times.

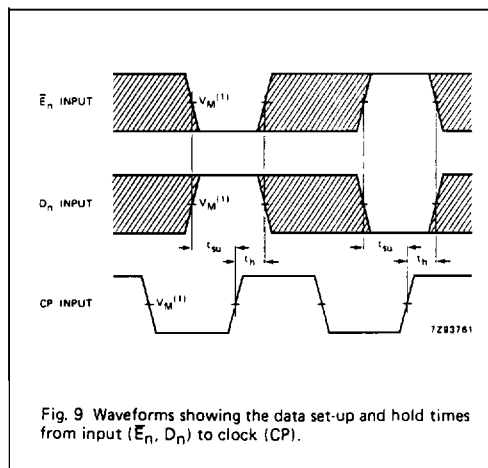

Fig. 9 Waveforms showing the data set-up and hold times from input (\overline{E}_n , D_n) to clock (CP).

Note to AC waveforms

(1) HC : $V_M = 50\%$; $V_I = \text{GND to } V_{CC}$.
HCT: $V_M = 1.3 \text{ V}$; $V_I = \text{GND to } 3 \text{ V}$.

Note to Fig. 9

The shaded areas indicate when the input is permitted to change for predictable output performance.