

## Description

- 125°C maximum total temperature operation
- Low profile surface mount inductor
- 8.3mm x 9.5mm x 4.5mm shielded drum core
- Ferrite core material
- Inductance range from 1.5µH to 100µH
- Current range from 9.1 Amps to 0.8 Amps
- Frequency range up to 1MHz

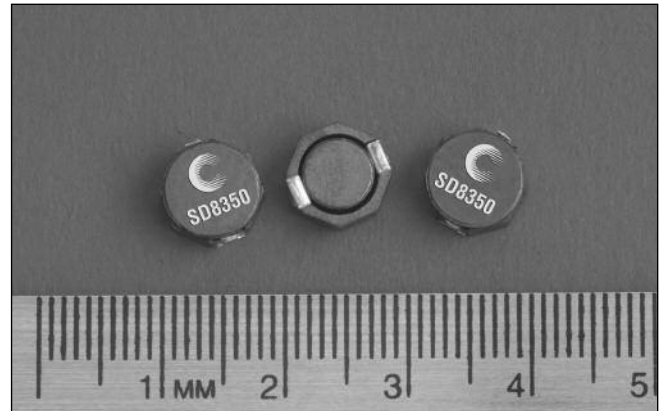

## Applications

- Server/Notebook power
- High Power LED driver, Portable devices
- Base Station, Telecom, and Networking
- Battery Chargers, RAM power supply
- Industrial and Automotive power systems
- Noise filtering output filter chokes
- Buck/Boost converters, Output converters

## Environmental Data

- Storage temperature range: -40°C to +125°C
- Operating temperature range: -40°C to +125°C (range is application specific)
- Solder reflow temperature: +260°C max. for 10 seconds maximum

## Packaging

- Supplied in tape and reel packaging, 750 per reel

Part Number	Rated Inductance (µH)	OCL (1) µH±30%	Irms(2) Amperes	Isat (3) Amperes	DCR (Ω) mΩ @20°C (Typical)	DCR (Ω) mΩ @20°C (Maximum)	K-factor (4)
SD8350-1R8-R	1.8	1.5	5.50	9.1	11.8	14.0	16.0
SD8350-3R9-R	3.9	3.2	4.50	6.3	16.2	19.0	9.6
SD8350-4R7-R	4.7	4.2	4.10	5.5	18.5	22.0	8.5
SD8350-6R8-R	6.8	6.8	3.90	4.4	20.8	25.0	7.6
SD8350-100-R	10	9.9	3.20	4.0	31.4	36.0	6.3
SD8350-150-R	15	13.6	2.30	2.9	45.0	53.0	5.3
SD8350-220-R	22	20.4	1.80	2.6	63.5	75.0	4.4
SD8350-330-R	33	31.4	1.40	2.2	111.4	125.0	3.5
SD8350-470-R	47	44.9	1.30	1.8	130.0	150.0	2.9
SD8350-680-R	68	65.1	1.00	1.5	200.8	240.0	2.4
SD8350-101-R	100	99.7	0.80	1.3	308.0	360.0	2.0

(1) Open Circuit Inductance Test Parameters: 100kHz, 0.1V, 0.0Adc.

(2) Irms: DC current for an approximate ΔT of 40°C without core loss. Derating is necessary for AC currents. PCB layout, trace thickness and width, air-flow, and proximity of other heat generating components will affect the temperature rise. It is recommended that the temperature of the part not exceed 125°C under worst case operating conditions verified in the end application.

(3) Isat Amperes peak for approximately 35% rolloff (@25°C)

(4) K-factor: Used to determine B p-p for core loss (see graph).

B p-p = K\*L\*ΔI, B p-p(mT), K: (K factor from table), L: (Inductance in µH), ΔI (Peak to peak ripple current in Amps).

(5) Part Number Definition: SD8350-xxx-R

SD8350 = Product code and size; -xxx = Inductance value in µH;

R = decimal point; If no R is present, third character = # of zeros.

-R suffix = RoHS compliant

## Mechanical Diagrams

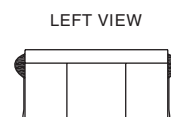
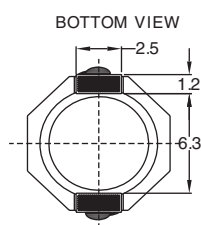
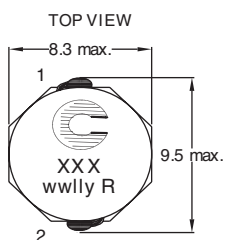

### RECOMMENDED PCB LAYOUT

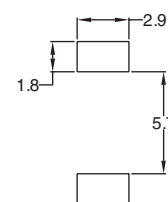

### SCHEMATIC

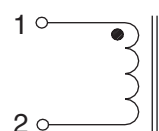

Dimensions are in millimeters.

xxx = Inductance value in µH. R = decimal point. If no R is present third character = # of zeros. wwlly = Date code, R = Revision level.

## Packaging Information

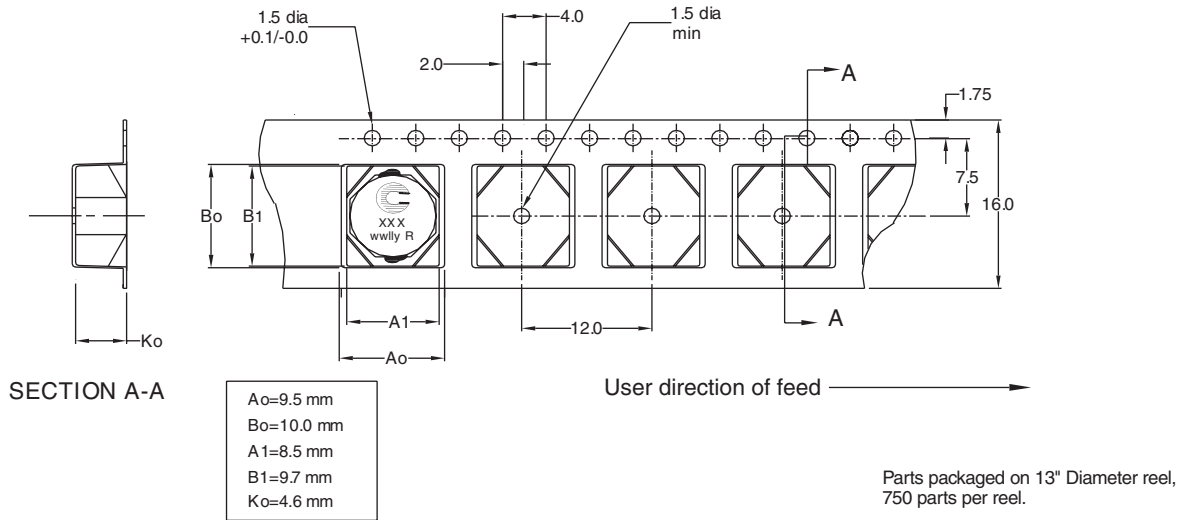

## Core Loss

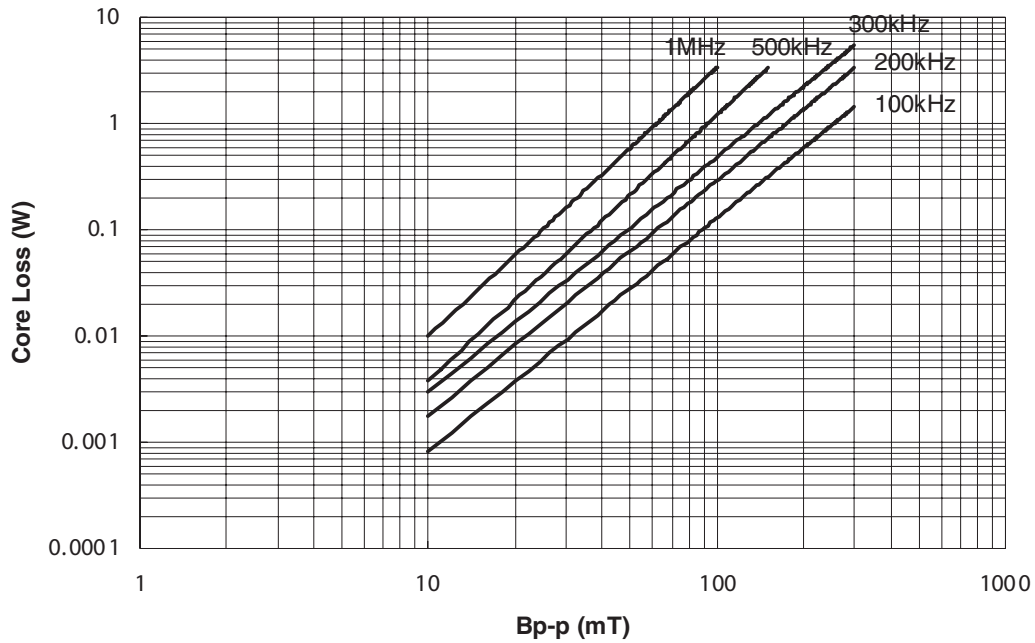

Temperature Rise vs. Loss

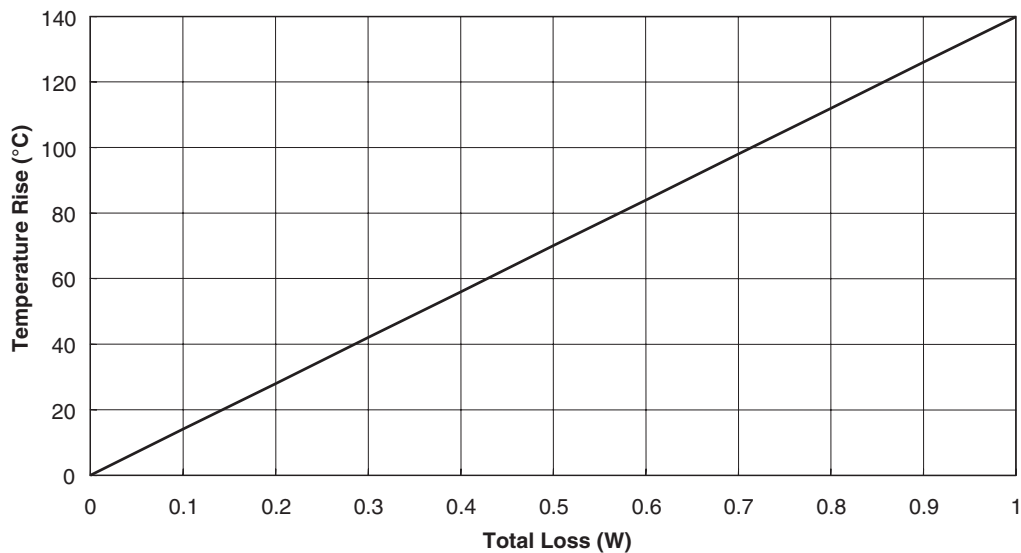

Inductance Characteristics

OCL Vs. Isat

