

**SOT-26**

## ORDERING INFORMATION

Product	Marking	Package
SN71052	702	SOT-26

### ▲ Marking Detail Information

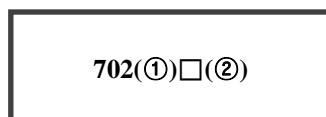

- ① Device Code
- ② Week Code

## Description

The SN71052 is a highly integrated solution for SMPS applications requiring a dual control loop to perform CV (constant voltage) and CC (constant current) regulation. The SN71052 integrates a voltage reference, Two Op-Amps (with OR-ed open-drain outputs), and a low-side current sensing circuit. The voltage reference, along with one Op-Amp, is the core of the voltage control loop; the current sensing circuit and the other Op-Amp make up the current control loop.

The external components needed to complete the two control loops are:

- A resistor divider that senses the output of the power supply (adapter, battery charger) and fixes the voltage regulation set point at the specified value;
- A sense resistor that feeds the current sensing circuit with a voltage proportional to the dc output current; this resistor determines the current regulation set point and must be adequately rated in terms of power dissipation;
- Frequency compensation components (R-C networks) for both loops.

## Application

- ◆ Battery chargers
- ◆ AC to DC adapters

## Block Diagram

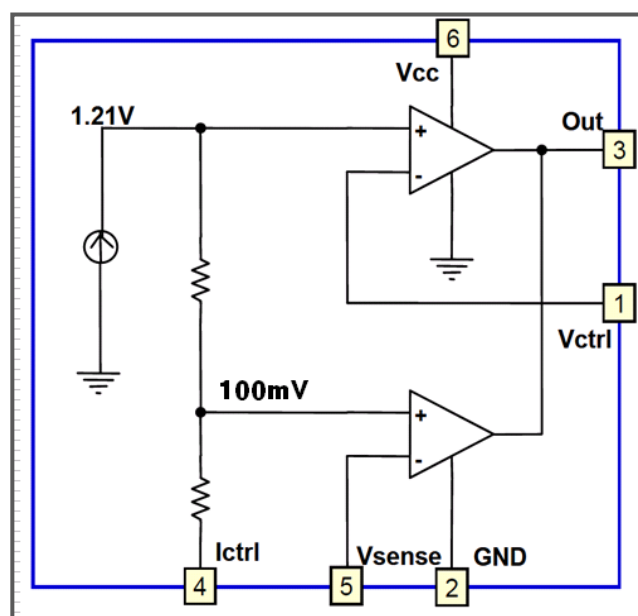

### ◆ Pin connection

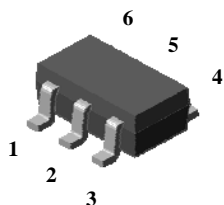

- 1 : Vctrl**
- 2 : GND**
- 3 : OUT**
- 4 : Ictrl**
- 5 : Vsense**
- 6: Vcc**

### ◆ Product Line-up

No.	Name	Function
1	Vctrl	Inverting input of the voltage loop Op-Amp. The pin will be tied to the mid-point of a resistor divider that senses the output voltage.
2	GND	Ground. Return of the bias current of the device. 0 V reference for all voltages. The pin should be tied as close to the ground output terminal of the converter as possible to minimize load current effect on the voltage regulation set point.
3	OUT	Common open-drain output of the two internal Op-Amps. The pin, able to sink current only, will be connected to the branch of the optocoupler's photodiode to transmit the error signal to the primary side.
4	Ictrl	Non-inverting input of the current loop Op-Amp. It will be tied directly to the hot (negative) end of the current sense resistor
5	Vsense	Inverting input of the current loop Op-Amp. The pin will be tied to the cold end of the current sense resistor through a decoupling resistor.
6	Vcc	Supply Voltage of the device. A small bypass capacitor (0.1 $\mu$ F typ.) to GND, located as close to IC's pins as possible, might be useful to get a clean supply voltage.

**◆ Absolute Maximum Ratings ( Ta = 25°C )**

Parameter	Symbol	Limits	Unit
DC Supply Voltage	V <sub>CC</sub>	-0.3 to 23	V
Power Dissipation	P <sub>d</sub>	500	mW
Maximum Junction Temperature	T <sub>Jmax</sub>	150	°C
Operating Junction Temperature Range	T <sub>opr</sub>	-10 ~ +85	°C
Thermal Resistance	R <sub>thja</sub>	250	°C/W
Storage Temperature Range	T <sub>stg</sub>	-55 ~ +150	°C

**◆ Operating Condition ( Ta = 25°C )**

Parameter	Symbol	Limits	Unit
DC Supply Voltage	V <sub>CC</sub>	2.5 to 20	V

### ◆ Electrical characteristics

(  $V_{CC}=+5V$ ,  $T_A=25^\circ C$  ; unless otherwise specified )

Characteristic	Symbol	Test Condition	Min.	Typ.	Max.	Unit
<b>[Total Current Consumption]</b>						
Quiescent Current	$I_{CC}$	$T_a = 25^\circ C$	-	0.8	2	mA
		$0 < T_a < 85^\circ C$	-	1.5	-	
<b>[ Voltage Control Loop OP-AMP ]</b>						
Transconductance Gain Sink Current Only (1)	$G_{mv}$	$T_a = 25^\circ C$	1	3.0	-	mA/mV
		$0 < T_a < 85^\circ C$	-	2.5	-	
Voltage Control Loop Reference (2)	$V_{ref}$	$T_a = 25^\circ C$	1.198	1.210	1.222	V
		$0 < T_a < 85^\circ C$	1.186	1.210	1.234	
Inverting Input Bias Current	$I_{ibv}$	$T_a = 25^\circ C$	-	40	-	nA
		$0 < T_a < 85^\circ C$	-	100	-	
<b>[Current Control Loop]</b>						
Transconductance Gain sink Current Only (3)	$G_{mi}$	$T_a = 25^\circ C$	1.5	7.0	-	mA/mV
		$0 < T_a < 85^\circ C$	-	-	-	
Current Loop Reference (4)	$V_{sense}$	$I_{out} = 2.5 \text{ mA}, T_a = 25^\circ C$	97	100	103	mV
		$0 < T_a < 85^\circ C$	96	-	104	
Current out of pin ICTRL at -100mV	$I_{ibi}$	$T_a = 25^\circ C$	-	25	-	$\mu A$
		$0 < T_a < 85^\circ C$	-	30	-	
<b>[Output Stage]</b>						
Low output Voltage at 10mA Sink current	$V_{ol}$	-	-	200	-	mV
Output Short Circuit Current. Output to $V_{CC}$ . Sink Current Only	$I_{os}$	-	-	35	70	mA

- 1) If the voltage on VCTRL (the negative input of the amplifier) is higher than the positive amplifier input ( $V_{ref} = 1.210V$ ), and it is increased by 1mV, the sinking current at the output OUT will be increased by 3.5mA.
- 2) The internal voltage reference is set at 1.210V (band-gap reference). The voltage control loop precision takes into account the cumulative effects of the internal voltage reference deviation as well as the input offset voltage of the trans-conductance operational amplifier. The internal voltage reference is fixed by band-gap, and trimmed to 0.5% accuracy at room temperature.
- 3) When the positive input at ICTRL is lower than -100mV, and the voltage is decreased by 1mV, the sinking Current at the output OUT will be increased by 7mA.
- 4) The internal current sense threshold is set to -100mV. The current control loop precision takes into account the cumulative effects of the internal voltage reference deviation as well as the input offset voltage of the trans-conduction operational amplifier.

◆ SOT-26 Outline Dimension (Unit : mm)

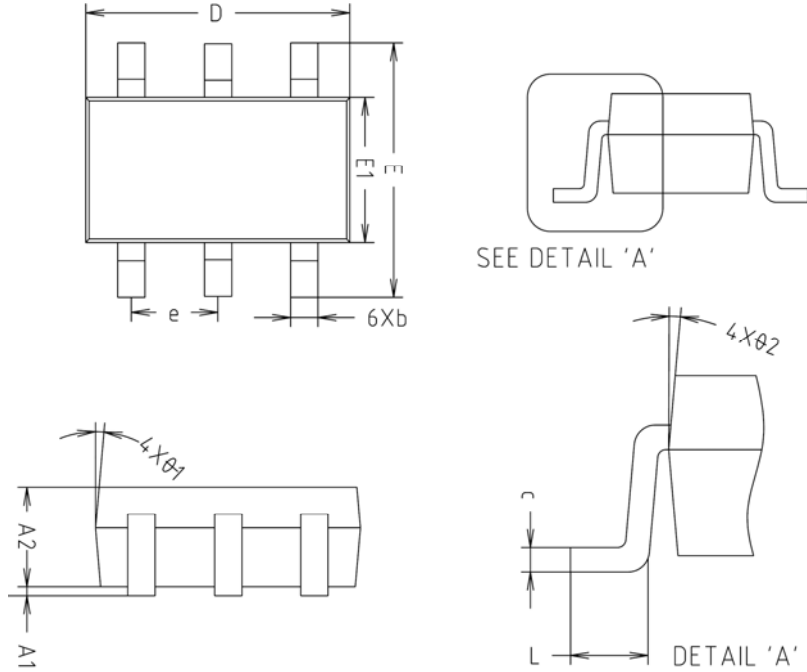

SYMBOL	MILLIMETERS(mm)			NOTE
	MINIMUM	NOMINAL	MAXIMUM	
A1	0.000	0.050	0.100	
A2	1.000	1.100	1.200	
b	-	0.400	0.450	
c	0.110	0.150	0.190	
D	2.800	2.900	3.000	
E	2.600	2.800	3.000	
E1	1.500	1.600	1.700	
e	0.930	0.950	0.970	
L	0.400	-	-	
$\theta1$	5° REF			
$\theta2$	5° REF			

※ Recommend PCB solder land [Unit: mm]

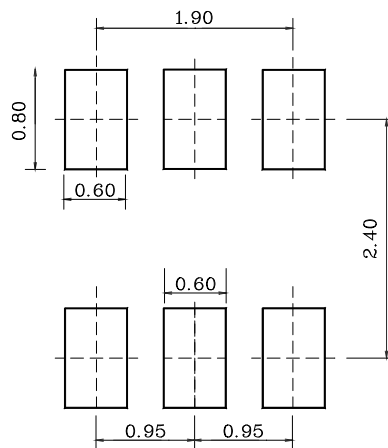

**The AUK Corp. products are intended for the use as components in general electronic equipment (Office and communication equipment, measuring equipment, home appliance, etc.).**

**Please make sure that you consult with us before you use these AUK Corp. products in equipments which require high quality and / or reliability, and in equipments which could have major impact to the welfare of human life(atomic energy control, airplane, spaceship, transportation, combustion control, all types of safety device, etc.). AUK Corp. cannot accept liability to any damage which may occur in case these AUK Corp. products were used in the mentioned equipments without prior consultation with AUK Corp..**

**Specifications mentioned in this publication are subject to change without notice.**