

■ Features

- 3.5V to 20V DC operation voltage
- Temperature compensation
- Wide operating voltage range
- Open-Collector pre-driver
- 25mA maximum sinking output current.
- Reverse Polarity Protection

■ Applications

- VCD/DVD loader, CD/DVD ROM
- Cover detector
- Speed measurement
- Home appliances
- Home safety

■ General Description

ATS137 is an switched Hall-Effect IC which is for contactless switching applications. The device includes an on-chip Hall voltage generator for magnetic sensing, an amplifier that amplifies the Hall voltage, a schmitt trigger to provide switching hysteresis for noise rejection, and an open-collector output. The bandgap regulator allows a wide operating voltage range.

ATS137 is rated for operating temperature range from -20°C to 85°C and voltage range from 3.5V to 20V.

■ Ordering Information

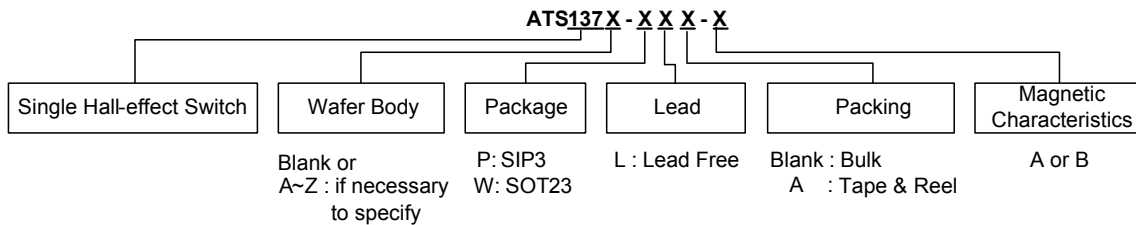

■ Typical Circuit

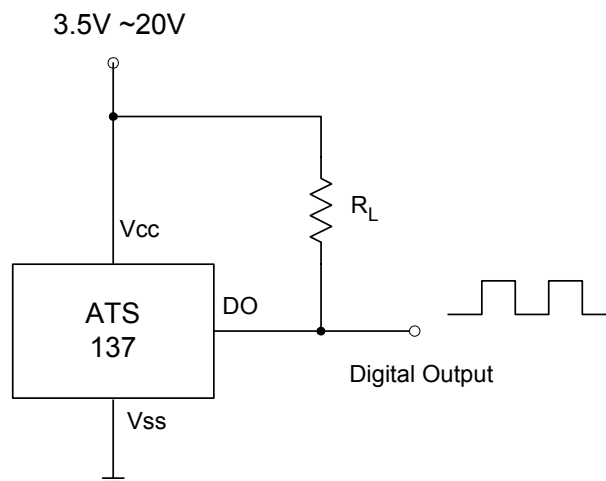

■ Functional Block Diagrams

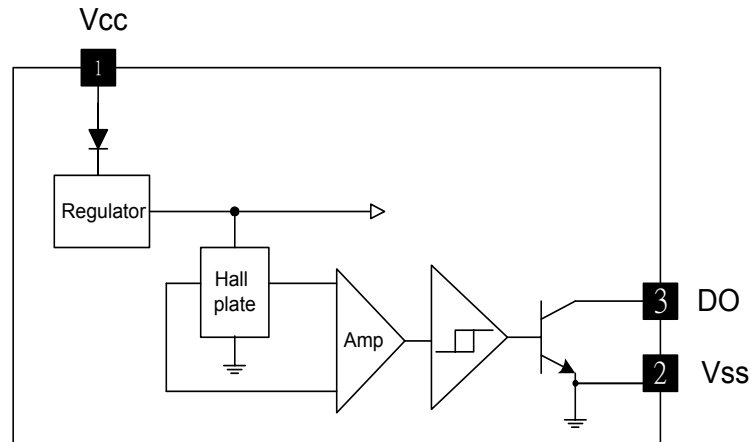

■ Pin Descriptions

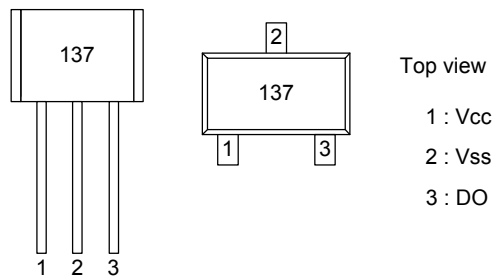

Name	P/I/O	Pin #	Description
Vcc	P	1	Positive Power Supply
Vss	P	2	Ground
DO	O	3	Digital Output

■ Absolute Maximum Ratings (at Ta=25°C)

Characteristics		Symbol	Values	Unit
Supply Voltage		V _{CC}	20	V
Reverse Vcc Polarity Voltage		V _{RCC}	-20	V
Magnetic Flux Density		B	Unlimited	
Output OFF Voltage		V _{ce}	30	V
Output "ON" Current	Continuous	I _c	25	mA
Operating Temperature		T _a	-20~+85	°C
Storage Temperature		T _s	-65~+150	°C
Maximum Junction Temp.		T _j	150	°C
Package Power Dissipation	SIP-3L	P _d	550	mW
	SOT23-3L		230	mW

■ Electrical Characteristics (Ta=+ 25°C)

Characteristic	Symbol	Test Conditions	Min	Typ	Max	Units
Supply Voltage	V _{cc}	—	3.5	-	20	V
Output Saturation Voltage	V _{ce(sat)}	V _{cc} =14V, I _c =20mA	-	300	700	mV
Output Leakage Current	I _{cex}	V _{ce} =14V, V _{cc} =14V	-	<0.1	10	uA
Supply Current	I _{cc}	V _{cc} =20V, Output Open	-	5	10	mA
Output Rise Time	t _r	V _{cc} =14V, R _L =820Ω, C _L =20pF	-	0.3	1.5	us
Output Falling Time	t _f	V _{cc} =14V, R _L =820Ω, C _L =20pF	-	0.3	1.5	us

■ Test Circuit

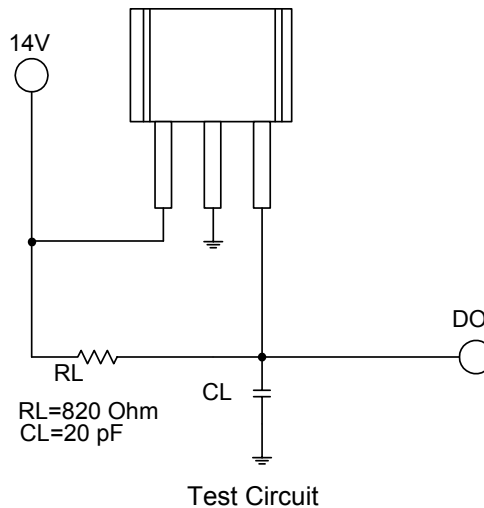

■ Magnetic Characteristics (Ta=25°C)

(1mT=10Gauss)

A grade

Parameter	Symbol	Min.	Typ.	Max.	Unit
Operate Point	B _{op}	-	-	100	Gauss
Release point	B _{rp}	10	-	-	Gauss
Hysteresis	B _{hys}	-	80	-	Gauss

B grade (for SIP3 only)

Parameter	Symbol	Min.	Typ.	Max.	Unit
Operate Point	B _{op}	-	-	130	Gauss
Release point	B _{rp}	10	-	-	Gauss
Hysteresis	B _{hys}	-	80	-	Gauss

■ Application Information

-Operating principle

ATS137 is a three pins Hall Effect switch IC which can turn magnetic flux variety to digital output signal. In other words, it is an interface from magnetic system to electrical one by Hall effect. The illustrations are shown in Fig.1.

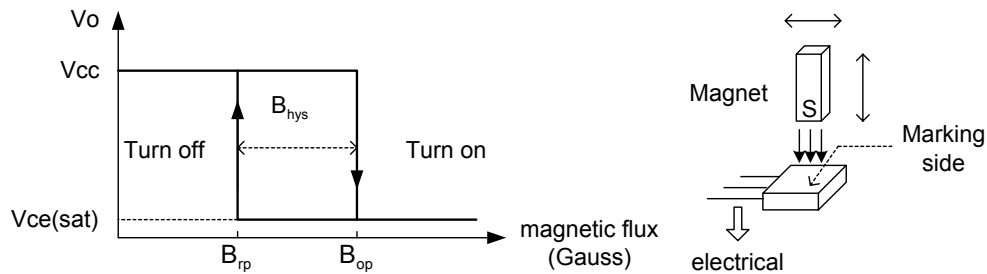

Fig.1 Hall-effect switch

Output driver is open-collector topology and maximum sink current (I_{sink}) is 25mA. The illustrated circuit is shown as Fig.2.

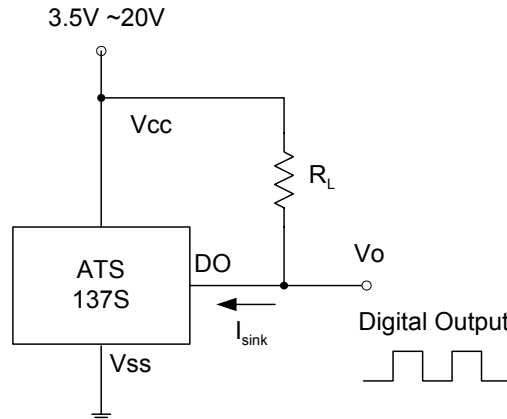

Fig.2 Application circuit

■ Application Information (Continued)

V_o will turn on (low) if the S magnetic flux larger than operation point (B_{op}), and turns off whenever the magnetic flux is removed and lower than release point (B_{rp}). The related waveforms are shown in Fig.3.

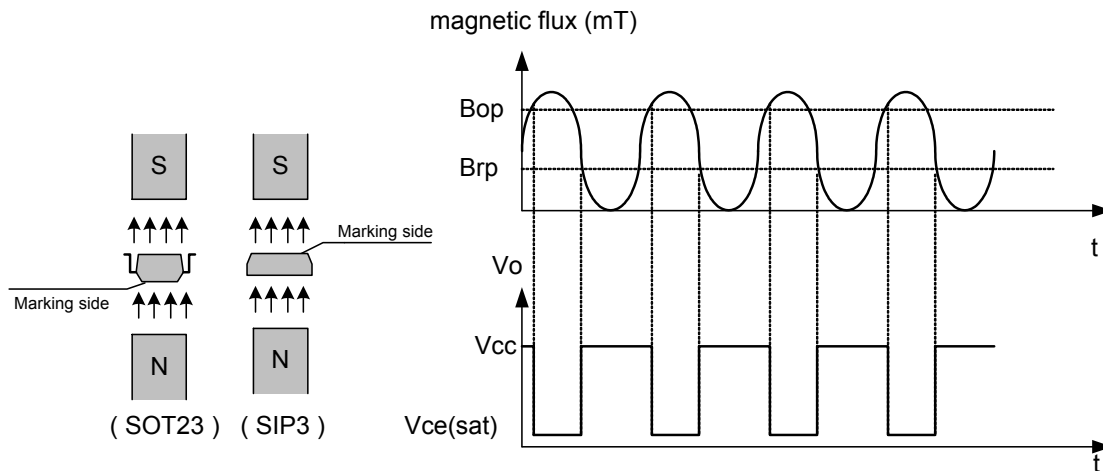

Fig.3 V_o and magnetic flux variety

The major applications are for contactless switching and shown as follows:

- VCD/DVD loader, CD/DVD ROM: Detect if the tray is opened or closed
- Cover detector (open/close): Cellular phone cover detector, Refrigerator door detector, Microwave oven door sensor... etc
- Home safety: instead of reed relay to detect the situation of door/window.
- Due to contactless and without mechanical contact point, its reliability and life cycle are much longer than reed relay. In addition, its switching speed is much faster than mechanical devices.

■ Performance Characteristics (SIP3)

Ta (°C)	25	50	60	70	80	85	90	95	100
Pd (mW)	550	440	396	352	308	286	264	242	220
Ta (°C)	105	110	115	120	125	130	135	140	150
Pd (mW)	198	176	154	132	110	88	66	44	0

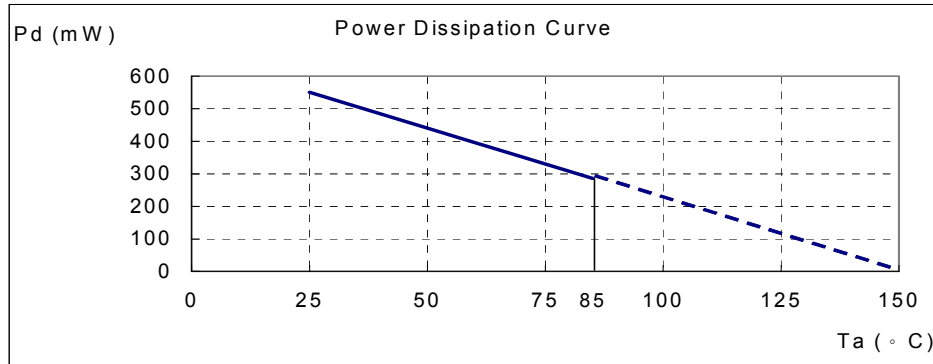

■ Performance Characteristics (SOT23-3)

Ta (°C)	25	50	60	70	80	85	90	100	110	120	125	130	140	150
Pd (mW)	230	184	166	147	129	120	110	92	74	55	46	37	18	0

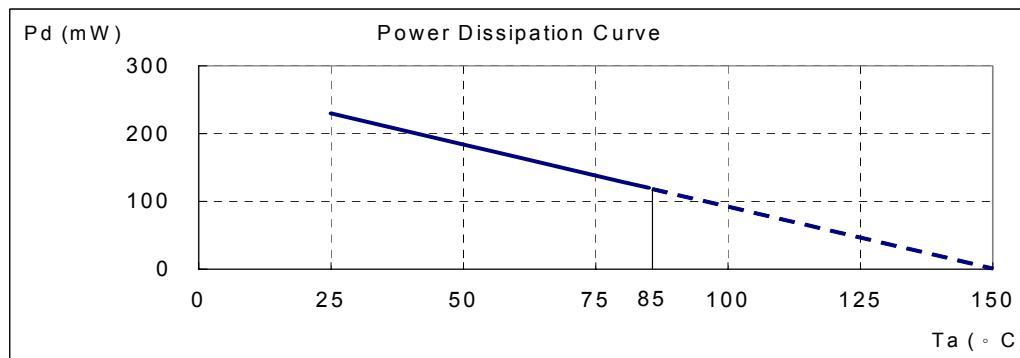

■ Marking Information

(1) SOT23

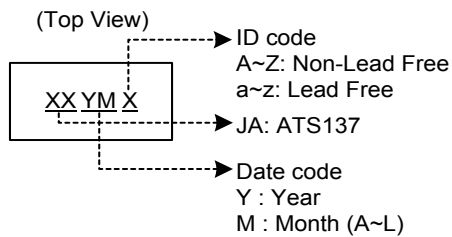

(2) SIP3

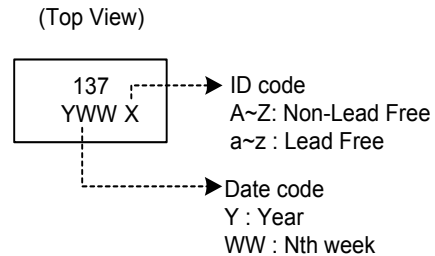

■ Package Information

(1) Package Type: SIP-3L

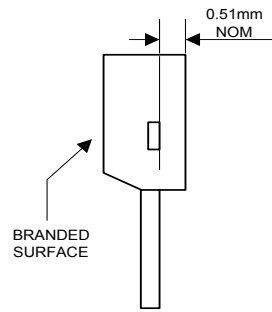

Active Area Depth

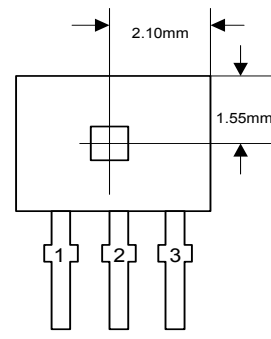

Sensor Location

Package Dimension

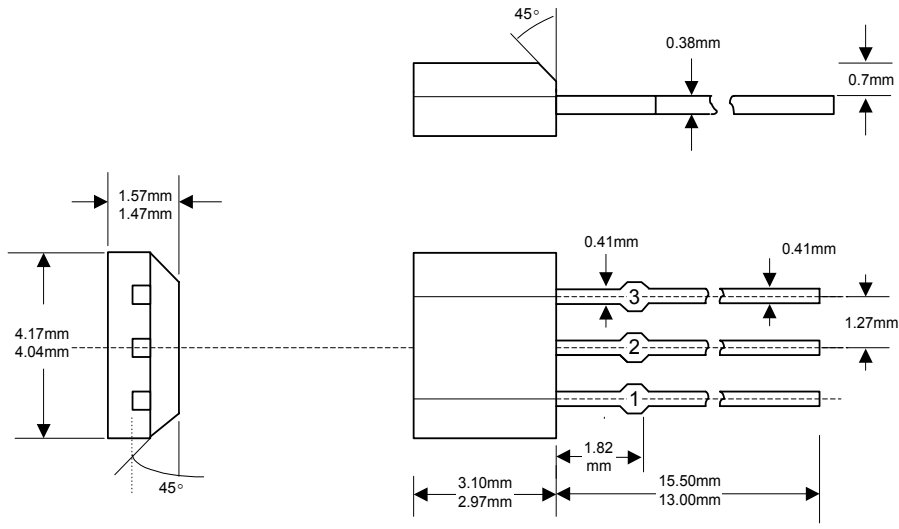

Single Hall Effect Switch

ATS137

■ Package Information (Continued)

(2) Package Type: SOT23-3L

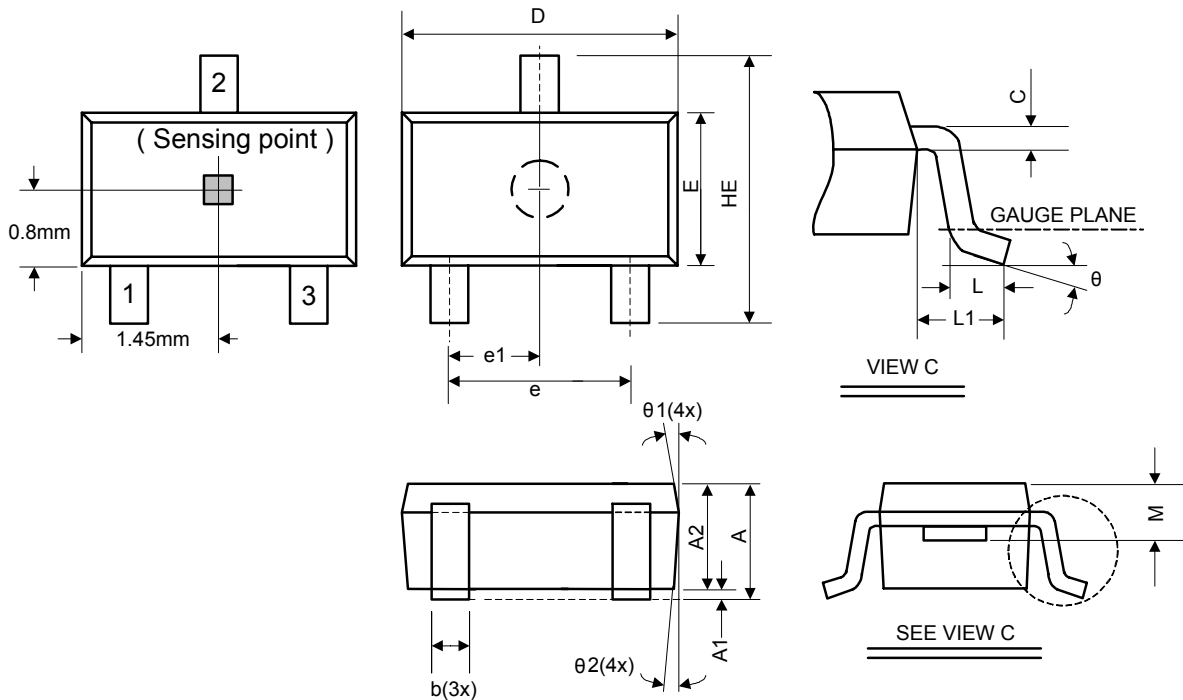

Symbol	Dimensions In Millimeters			Dimensions In Inches		
	Min.	Nom.	Max.	Min.	Nom.	Max.
A	1.05	-	1.35	0.041	-	0.053
A1	0.05	-	0.15	0.002	-	0.006
A2	1.00	1.10	1.20	0.039	0.043	0.047
b	0.25	-	0.50	0.010	-	0.020
C	0.08	-	0.20	0.003	-	0.008
D	2.70	2.90	3.00	0.106	0.114	0.118
E	1.50	1.60	1.70	0.059	0.063	0.067
HE	2.60	2.80	3.00	0.102	0.110	0.118
L	0.30	-	0.60	0.012	-	0.024
L1	0.50	0.60	0.70	0.020	0.024	0.028
M	0.73	0.78	0.83	0.029	0.031	0.033
e	1.80	1.90	2.00	0.071	0.075	0.079
e1	0.85	0.95	1.05	0.033	0.037	0.041
theta	0°	5°	10°	0°	5°	10°
theta1	3°	5°	7°	3°	5°	7°
theta2	6°	8°	10°	6°	8°	10°