

April 1995

8A, 700V - 1000V Ultrafast Diodes

Features

- Ultrafast with Soft Recovery Characteristic ($t_{RR} < 75\text{ns}$)
- +175°C Rated Junction Temperature
- Reverse Voltage Up to 1000V
- Avalanche Energy Rated

Applications

- Switching Power Supply
- Power Switching Circuits
- General Purpose

Description

MUR870E, MUR880E, MUR890E, MUR8100E and RURP870, RURP880, RURP890, RURP8100 are ultrafast dual diodes ($t_{RR} < 75\text{ns}$) with soft recovery characteristics. They have a low forward voltage drop and are of planar, silicon nitride passivated, ion-implanted, epitaxial construction.

These devices are intended for use as energy steering/clamping diodes and rectifiers in a variety of switching power supplies and other power switching applications. Their low stored charge and ultrafast recovery with soft recovery characteristics minimizes ringing and electrical noise in many power switching circuits thus reducing power loss in the switching transistor.

Package

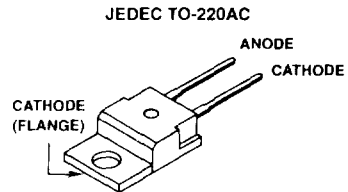

Symbol



PACKAGING AVAILABILITY

PART NUMBER	PACKAGE	BRAND
MUR870E	TO-220AC	MUR870
MUR880E	TO-220AC	MUR880
MUR890E	TO-220AC	MUR890
MUR8100E	TO-220AC	MUR8100
RURP870	TO-220AC	RURP870
RURP880	TO-220AC	RURP880
RURP890	TO-220AC	RURP890
RURP8100	TO-220AC	RURP8100

NOTE: When ordering, use entire part number.

Absolute Maximum Ratings $T_C = +25^\circ\text{C}$, Unless Otherwise Specified

	MUR870E RURP870	MUR880E RURP880	MUR890E RURP890	MUR8100E RURP8100
Peak Repetitive Reverse Voltage V_{RRM}	700V	800V	900V	1000V
Working Peak Reverse Voltage V_{RWM}	700V	800V	900V	1000V
DC Blocking Voltage V_R	700V	800V	900V	1000V
Average Rectified Forward Current $I_{F(AV)}$	8A	8A	8A	8A
Total device forward current at rated V_R and $T_C = +150^\circ\text{C}$				
Peak Forward Repetitive Current I_{FRM}	16A	16A	16A	16A
(Rated V_R , square wave 20kHz)				
Nonrepetitive Peak Surge Current I_{FSM}	100A	100A	100A	100A
(Surge applied at rated load condition halfwave 1 phase 60Hz)				
Operating and Storage Temperature T_{STG}, T_J	-55°C to +175°C	-55°C to +175°C	-55°C to +175°C	-55°C to +175°C

Electrical Specifications $T_C = +25^\circ\text{C}$, Unless Otherwise Specified.

SYMBOL	TEST CONDITION	LIMITS											UNITS	
		MUR870E, RURP870			MUR880E, RURP880			MUR890E, RURP890			MUR8100E, RURP8100			
		MIN	TYP	MAX	MIN	TYP	MAX	MIN	TYP	MAX	MIN	TYP		MAX
V_F	$I_F = 8\text{A}$ $T_C = +150^\circ\text{C}$	-	-	1.50	-	-	1.50	-	-	1.50	-	-	1.50	V
	$I_F = 8\text{A}$ $T_C = +25^\circ\text{C}$	-	-	1.80	-	-	1.80	-	-	1.80	-	-	1.80	V
I_R at $T_C = +150^\circ\text{C}$	$V_R = 700\text{V}$	-	-	500	-	-	-	-	-	-	-	-	-	μA
	$V_R = 800\text{V}$	-	-	-	-	-	500	-	-	-	-	-	-	μA
	$V_R = 900\text{V}$	-	-	-	-	-	-	-	-	500	-	-	-	μA
	$V_R = 1000\text{V}$	-	-	-	-	-	-	-	-	-	-	-	500	μA
I_R at $T_C = +25^\circ\text{C}$	$V_R = 700\text{V}$	-	-	100	-	-	-	-	-	-	-	-	-	μA
	$V_R = 800\text{V}$	-	-	-	-	-	100	-	-	-	-	-	-	μA
	$V_R = 900\text{V}$	-	-	-	-	-	-	-	-	100	-	-	-	μA
	$V_R = 1000\text{V}$	-	-	-	-	-	-	-	-	-	-	-	100	μA
t_{RR}	$I_F = 1\text{A}$	-	-	100	-	-	100	-	-	100	-	-	100	ns
	$I_F = 8\text{A}$	-	-	110	-	-	110	-	-	110	-	-	110	ns
t_A	$I_F = 1\text{A}$	-	40	-	-	40	-	-	40	-	-	40	-	ns
	$I_F = 8\text{A}$	-	45	-	-	45	-	-	45	-	-	45	-	ns
t_B	$I_F = 1\text{A}$	-	20	-	-	20	-	-	20	-	-	20	-	ns
	$I_F = 8\text{A}$	-	20	-	-	20	-	-	20	-	-	20	-	ns
$R_{\theta JC}$		-	-	2.0	-	-	2.0	-	-	2.0	-	-	2.0	$^\circ\text{C/W}$
E_{AVL}	See Fig. 7 & 8	-	-	20	-	-	20	-	-	20	-	-	20	mj

DEFINITIONS

V_F = Instantaneous forward voltage (pw = 300 μs , D = 2%).

I_R = Instantaneous reverse current.

t_{RR} = Reverse recovery time at $dI_F/dt = 100\text{A}/\mu\text{s}$ (See Figure 2), summation of $t_A + t_B$.

t_A = Time to reach peak reverse current at $dI_F/dt = 100\text{A}/\mu\text{s}$ (See Figure 2).

t_B = Time from peak I_{RM} to projected zero crossing of I_{RM} based on a straight line from peak I_{RM} through 25% of I_{RM} (See Figure 2).

$R_{\theta JC}$ = Thermal resistance junction to case.

E_{AVL} = Controlled avalanche energy (See Figures 7 and 8).

pw = pulse width.

D = duty cycle.

5
ULTRAFAST
SINGLE DIODES

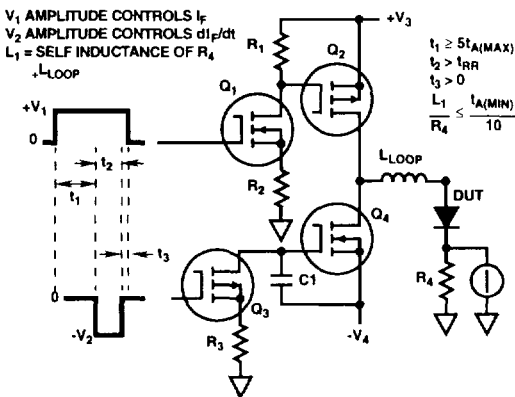

FIGURE 1. t_{RR} TEST CIRCUIT

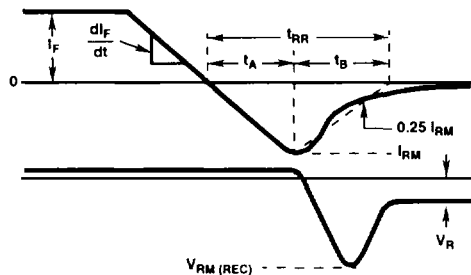

FIGURE 2. DEFINITIONS OF t_{RR} , t_A AND t_B

Typical Performance Curves

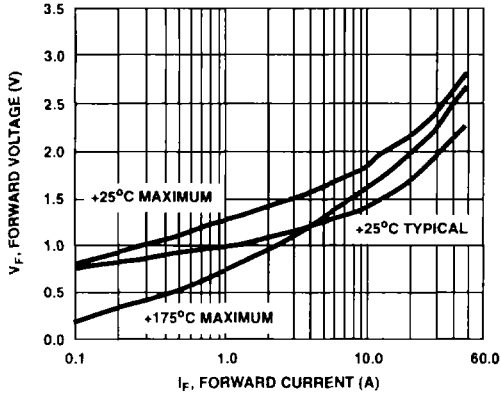

FIGURE 3. FORWARD VOLTAGE vs FORWARD CURRENT CHARACTERISTIC

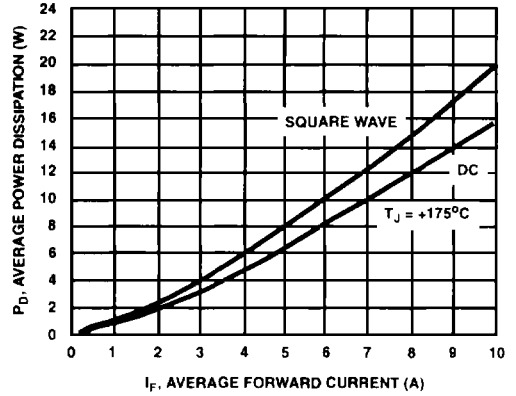

FIGURE 4. AVERAGE FORWARD CURRENT vs AVERAGE POWER DISSIPATION

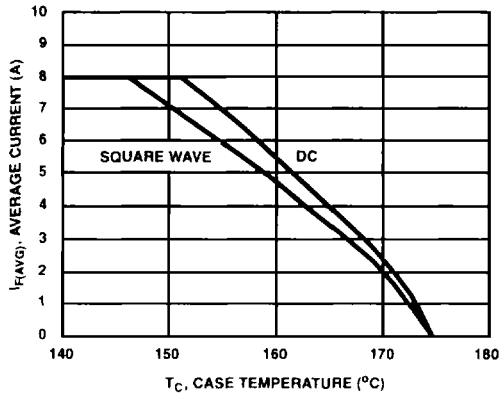

FIGURE 5. AVERAGE FORWARD CURRENT vs CASE TEMPERATURE

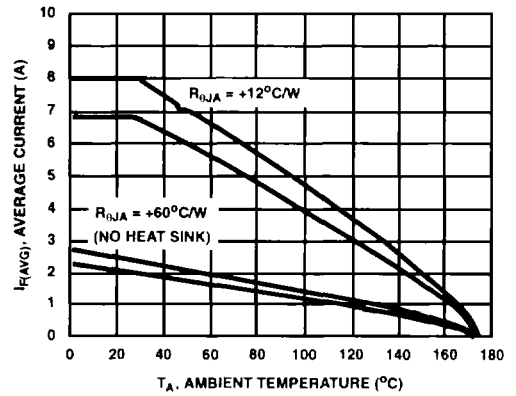

FIGURE 6. AVERAGE FORWARD CURRENT vs AMBIENT TEMPERATURE

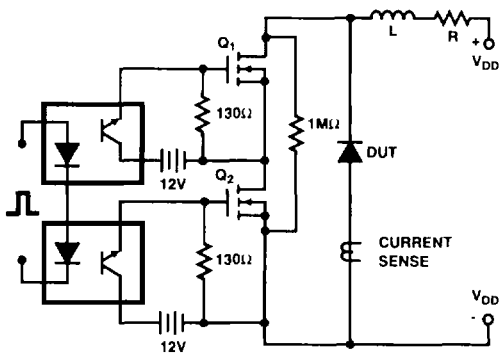

FIGURE 7. AVALANCHE ENERGY TEST CIRCUIT

$$I_{L,peak} = 1A, L = 40mH, R < 0.1\Omega, E_{AVL} = (1/2) L I^2 [V_{AVL}/(V_{AVL} - V_{DD})]$$

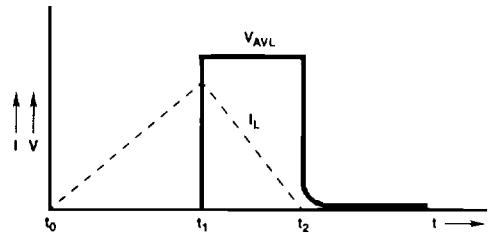

FIGURE 8. CURRENT VOLTAGE WAVEFORM