

Bi-Directional DC Motor Driver

The KIA7291P/S/F are bridge driver with output voltage control.

FEATURES

- 4 Modes Available (CW/CCW/STOP/BRAKE)
- Output Current : P type 1.0A(AVE.) 2.0A(PEAK)
S/F type 0.4A(AVE.) 1.2A(PEAK)
- Wide Range of Operating Voltage : $V_{CC(opr)}=4.5\sim 20V$
: $V_{S(opr)}=0\sim 20V$
: $V_{ref(opr)}=0\sim 20V$
: $V_{ref}\leq V_S$
- Build in Thermal Shutdown, Over Current Protector and Punch-Through Current Restriction Circuit.
- Stand-by mode available (STOP MODE)
- Hysteresis for All Inputs.

MAXIMUM RATINGS (Ta=25°C)

CHARACTERISTIC		SYMBOL	RATING	UNIT
Supply Voltage		V_{CC}	25	V
Motor Drive Voltage		V_S	25	V
Reference Voltage		V_{ref}	25	V
Output Current	PEAK	P TYPE	2.0	A
		S/F TYPE	1.2	
	AVE.	P TYPE	2.0	
		S/F TYPE	0.4	
Power Dissipation	P TYPE	P_D	(*1) 12.5	W
	S TYPE		(*2) 0.95	
	F TYPE		(*3) 1.40	
Operating Temperature		T_{opr}	-30~75	°C
Storage Temperature		T_{stg}	-55~150	°C

(*1) $T_C=25^\circ C$ (KIA7291P)

(*2) No heat sink

(*3) PCB (60×30×1.6mm, occupied copper area in excess of 50%)Mounting Condition

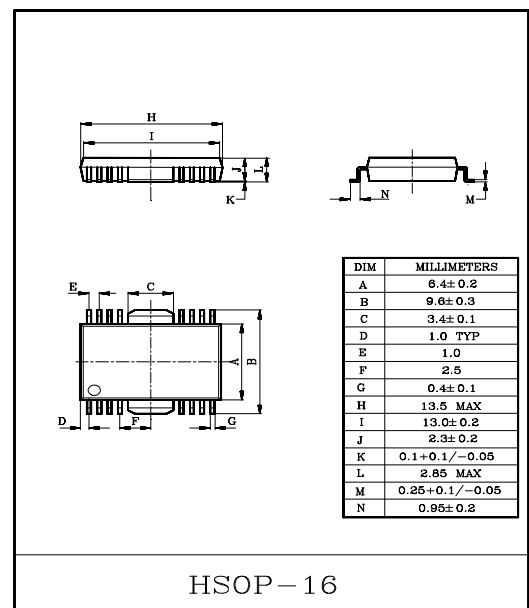
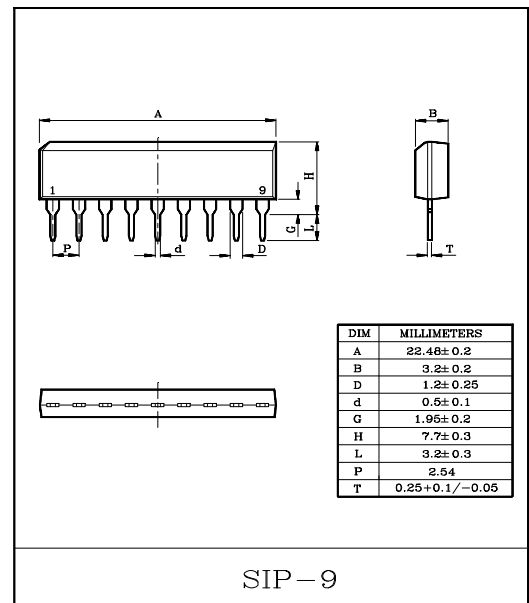
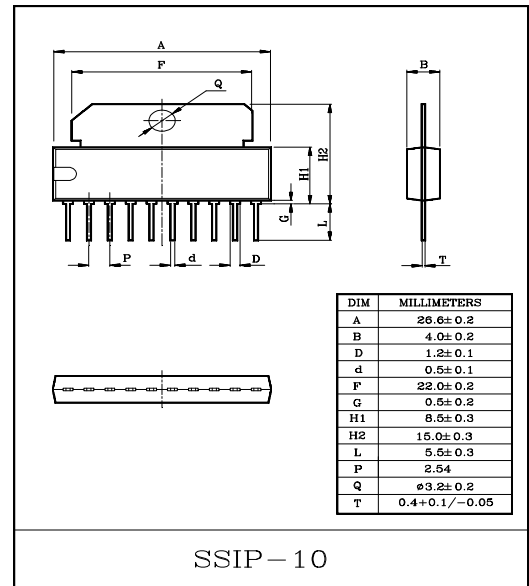

KIA7291P/S/F

BLOCK DIAGRAM

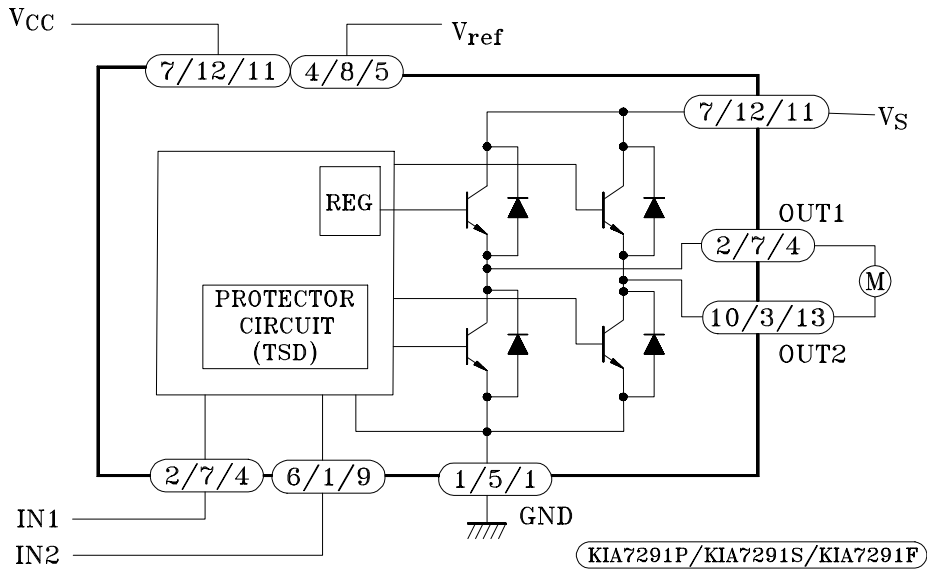

PIN FUNCTION

PIN No.			SYMBOL	FUNCTIONAL DESCRIPTION
P	S	F		
7	2	11	V_{cc}	Supply voltage terminal for logic
8	6	15	V_s	Supply voltage terminal for Motor driver
4	8	5	V_{ref}	Supply voltage terminal for control
1	5	1	GND	GND terminal
5	9	7	IN1	Input terminal
6	1	9	IN2	Input terminal
2	7	4	OUT1	Output terminal
10	3	13	OUT2	Output terminal

P Type : PIN ③, ⑨ : NC

S Type : PIN ④ : NC

F Type : PIN ②, ③, ⑥, ⑧, ⑩, ⑫, ⑭, and ⑯ : NC

For F Type, We recommend FIN to be connected to GND.

FUNCTION

INPUT		OUTPUT		MODE
IN1	IN2	OUT1	OUT2	
0	0	∞	∞	STOP
1	0	H	L	CW/CCW
0	1	L	H	CCW/CW
1	1	L	L	BRAKE

∞ : High Impedance

(Note) Inputs are all high active type.

KIA7291P/S/F

ELECTRICAL CHARACTERISTICS

(Unless otherwise specified, $V_{CC}=12V$, $V_S=18V$, $T_a=25^\circ C$)

CHARACTERISTIC			SYMBOL	TEST CIRCUIT	TEST CONDITION	MIN.	TYP.	MAX.	UNIT	
Supply Current			I_{CC1}	1	Output OFF, CW/CCW mode	-	8.0	13.0	mA	
			I_{CC2}		Output OFF, CW/CCW mode	-	0	50	μA	
			I_{CC3}		Output OFF, Brake mode	-	6.5	10.0	mA	
Input Operating Voltage	1 (High)	V_{IN1}	2	$T_j=25^\circ C$	-	3.5	-	5.5	V	
	2 (Low)	V_{IN2}				GND	-	0.8		
Input Current					I_{IN}	$V_{IN}=3.5V$, Sink mode	-	3	10	μA
Input Hysteresis Voltage					ΔV_T	-	-	0.7	-	V
Saturation Voltage	P/S/F Type	Upper Side	3	$V_{ref}=V_S$, $V_{out}-V_S$ measure $I_O=0.2A$, CW/CCW mode	-	0.9	1.2	V		
		Lower Side				$V_{SAT L-1}$	-		0.8	1.2
	S/F Type	Upper Side			$V_{SAT U-2}$	-	1.0		1.35	
		Lower Side			$V_{SAT L-2}$	-	0.9		1.35	
	P Type	Upper Side			$V_{SAT U-2}$	-	1.3		1.8	
		Lower Side			$V_{SAT L-2}$	-	1.2		1.85	
Output Voltage	S/F Type		3	$V_{ref}=10V$, $V_{out}-GND$ measure $I_O=0.2A$, CW/CCW mode	-	11.2	-	V		
						$V_{SAT U-2'}$	10.4		10.9	12.2
	P Type				$V_{SAT U-3'}$	-	11.0		-	
					$V_{SAT U-4'}$	10.2	10.7		12.0	
Leakage Current	Upper Side		4	$V_L=25V$	-	-	-	50	μA	
	Lower Side					I_{LL}	-	-		50
Diode Forward Voltage	S/F Type	Upper Side	5	$I_F=0.4A$	-	-	1.5	-	V	
	P Type	Lower Side				V_{FU-2}	-	2.5		-
		S/F Type				Upper Side	V_{FU-1}	-		0.9
	P Type	Lower Side				V_{FU-2}	-	1.2		-
Reference Current			I_{ref}	2	$V_{ref}=10V$, Source mode	-	20	40	μA	

KIA7291P/S/F

TEST CIRCUIT 1
 I_{CC1} , I_{CC2} , I_{CC3}

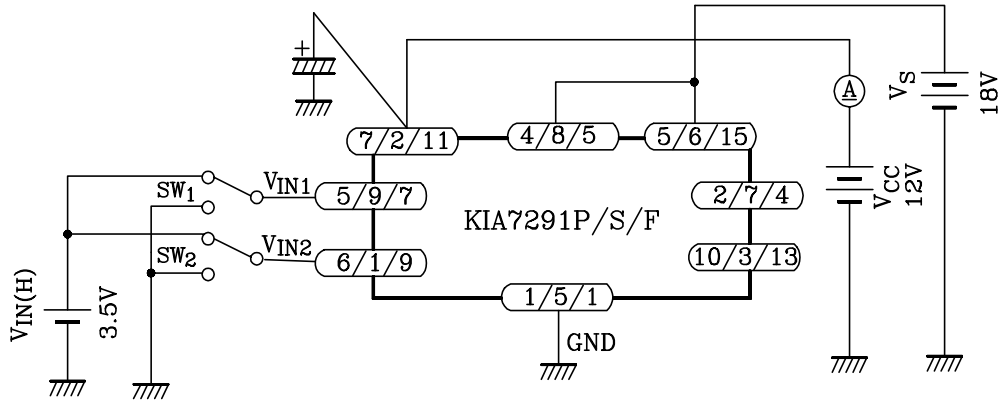

(Note) HEAT FIN of KIA7291F is connected to GND.

TEST CIRCUIT 2
 V_{IN1} , V_{IN2} , I_{IN} , ΔV_T , I_{ref}

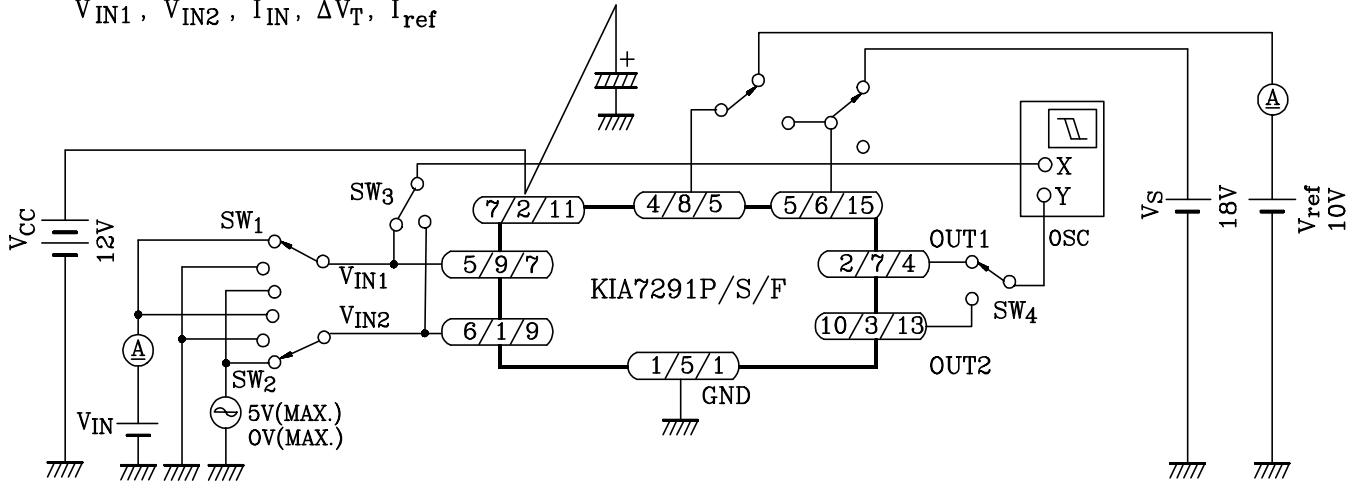

KIA7291P/KIA7291S/KIA7291F

(Note) HEAT FIN of KIA7291F is connected to GND.

KIA7291P/S/F

TEST CIRCUIT 3

V_{SAT} U-1, 2, 3 V_{SAT} L-1, 2, 3 V_{SAT} U-1', 2', 3', 4'

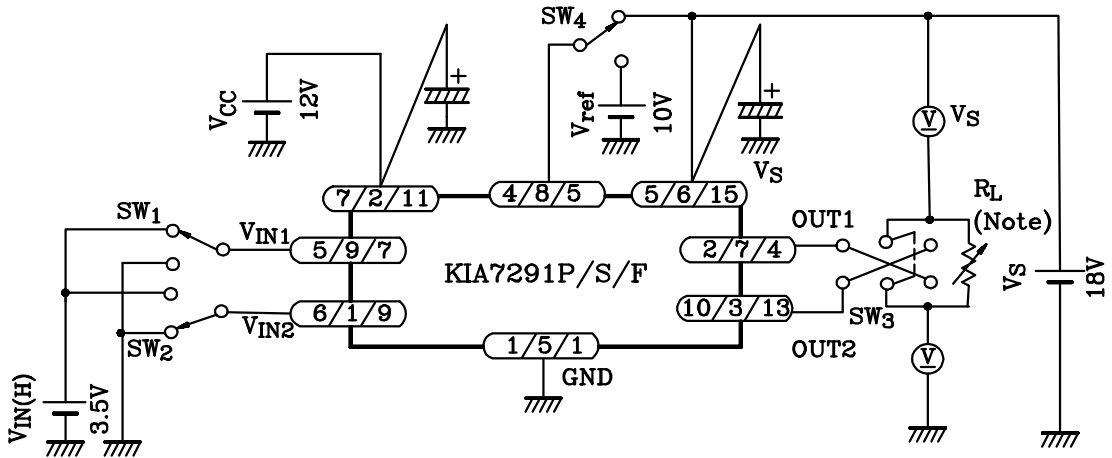

(Note) I_{OUT} calibration is required to adjust specified values of test conditions by R_L ($I_{OUT}=0.2A/0.4A/0.5A/1.0A$)

(Note) HEAT FIN of KIA7291F of connected to GND.

TEST CIRCUIT 4

I_L U, L

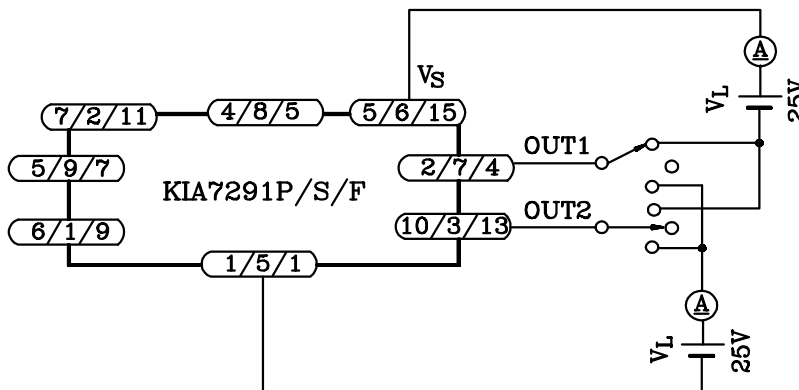

KIA7291P/KIA7291S/KIA7291F

(Note) HEAT FIN of KIA7291F of connected to GND.

TEST CIRCUIT 5

V_F U-1, 2, V_F L-1, 2,

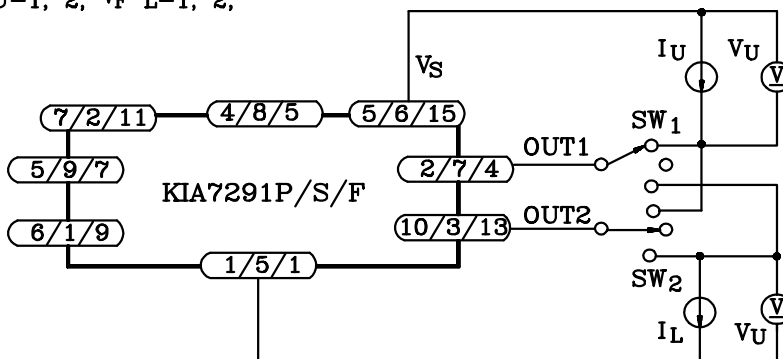

KIA7291P/S/F

NOTES

Input circuit

Input Terminals of pin ⑤ and ⑥ (KIA7291P) are all high active type and have a hysteresis of 0.7V (typ.), 3μA (typ.) of source mode input current is required.

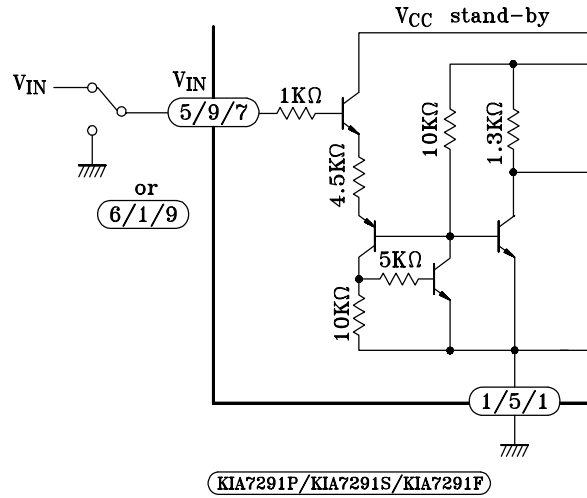

Output circuit

Output voltage is controlled by V_{ref} voltage.
Relationship between V_{OUT} and V_{ref} is

$$V_{OUT} = V_{BE} (\approx 0.7) + V_{ref}$$

V_{ref} terminal required to connect to V_S terminal for stable operation in case of no requirement of $V_{ref} \leq V_S$

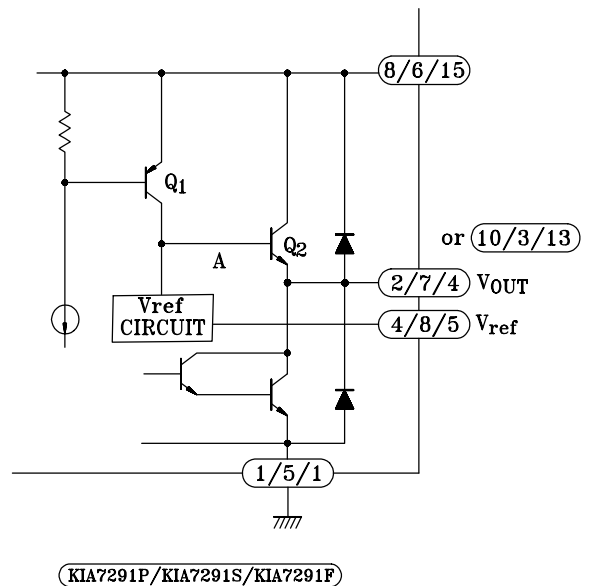

KIA7291P/S/F

APPLICATION CIRCUIT

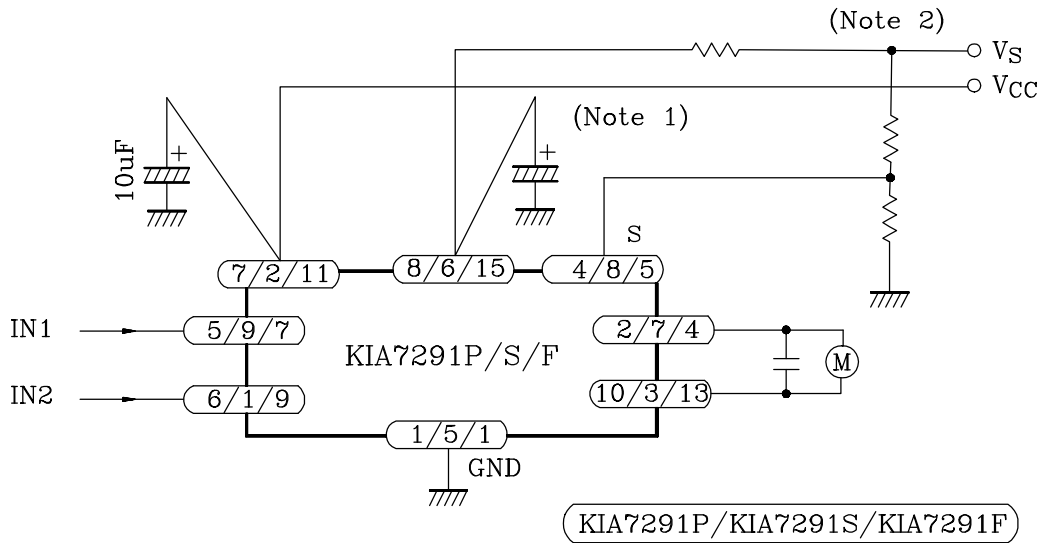

(Note1) Experiment to find the optimum capacitor value.

(Note2) To protect against excess current, current limitation resistor R should be inserted where necessary.

NOTES

- Be careful when switching the input because rush current may occur. When switching, stop mode should be entered or current limitation resistor R should be inserted.
- The IC functions cannot be guaranteed when turning power on or off. Before using the IC for application, check that there are no problems.
- Utmost care is necessary in the design of the output line, V_S, V_{CC} and GND line since IC may be destroyed due to short-circuit between outputs, air contamination fault, or fault by improper grounding.

KIA7291P/S/F

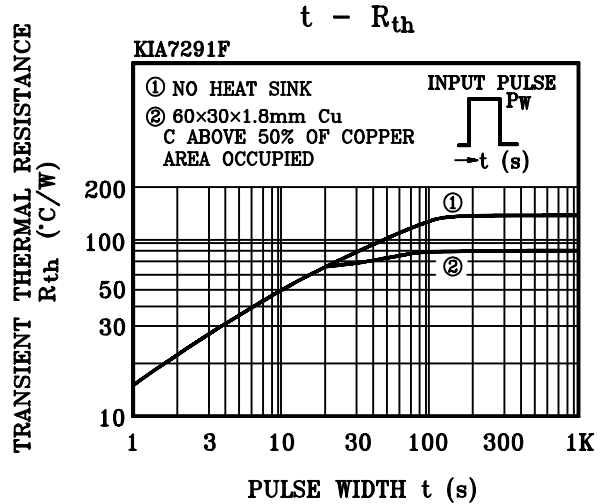
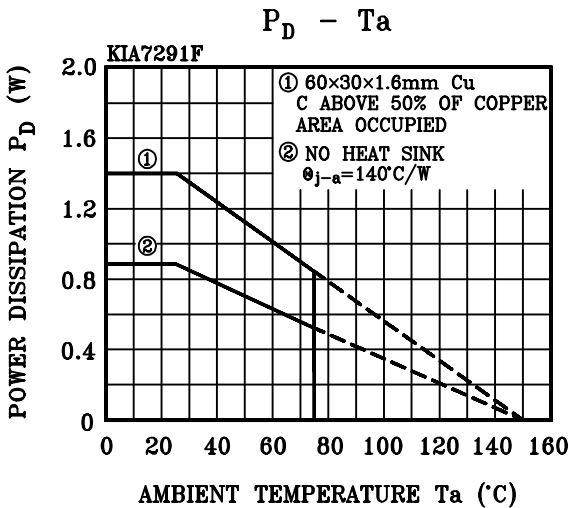
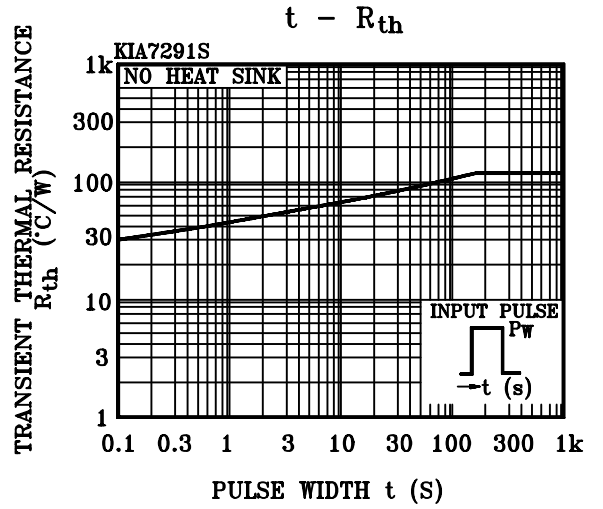
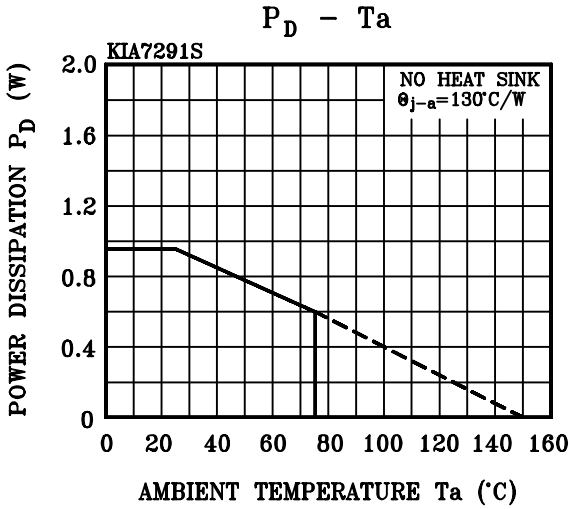
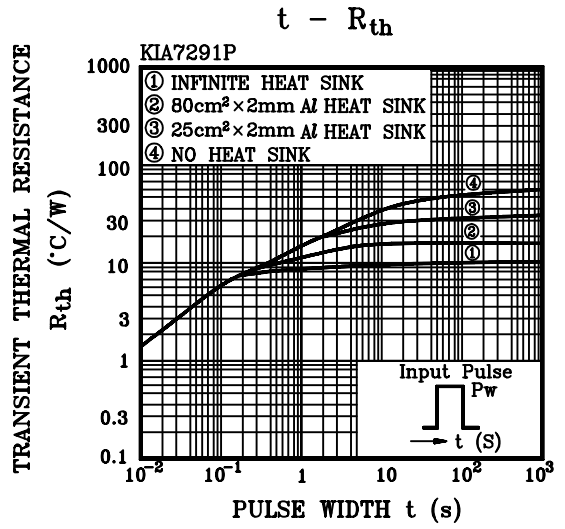
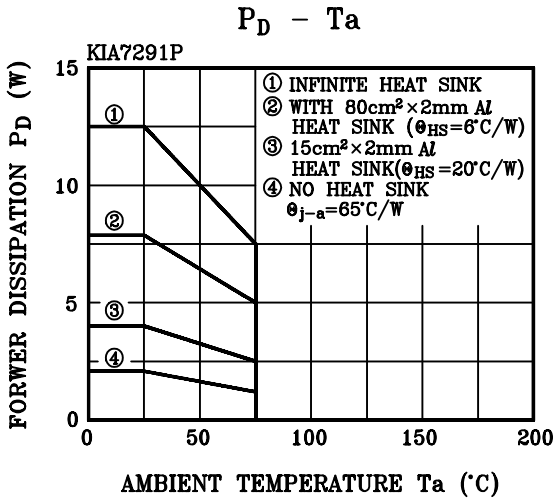

KIA7291P/S/F

