



- 3.2.2 GROUP B TESTING (7 SAMPLES APPROVED FROM GROUP A).
  - 3.2.2.1 SUB-GROUP 1 (3 SAMPLES)
    - 3.2.2.1.1 LOW TEMPERATURE OPERATION
      - 3.2.2.1.1.1 USE FINAL ELECTRICAL MEASUREMENTS FROM GROUP A
      - 3.2.2.1.1.2 DISSIPATE LOW POWER FOR A DURATION OF 45 +5/-0 MINUTES. ALLOW TO STABILIZE AT 25°C FOR 24 HOURS.
    - 3.2.2.1.2 AFTER LOW TEMPERATURE ELECTRICAL MEASUREMENTS - MEASURE AND RECORD VSWR @ 1 GHZ AND ATTENUATION AT DC (0 GHZ) AND 1.0 GHZ.
    - 3.2.2.1.3 HIGH TEMPERATURE BAKE – +125°C +/- 5°C FOR 100 HRS THEN STABILIZE AT 25°C FOR 4 HRS.
      - 3.2.2.1.3.1 VISUAL EXAMINATION - INSPECT FOR EVIDENCE OF MECHANICAL DAMAGE.
    - 3.2.2.1.4 AFTER HIGH TEMPERATURE BAKE ELECTRICAL TEST - MEASURE AND RECORD VSWR @ 1 GHZ AND ATTENUATION AT DC (0 GHZ) AND 1.0 GHZ.
    - 3.2.2.1.5 TERMINATION ADHESION - SOLDER A WIRE AND PULL WITH 15 GRAMS PERPENDICULAR TO AND AWAY FROM THE SURFACE AREA.
      - 3.2.2.1.5.1 VISUAL INSPECTION – THERE SHALL BE NO SEPARATION OF MATERIAL.
    - 3.2.2.1.6 TERMINATION SOLDERABILITY IMMERSE EACH SAMPLE 5 SECONDS IN A SOLDER POT HELD AT 220°C +/- 5°C USING 60/40 OR 63/37 TIN-LEAD COMPOSITION.
  - 3.2.2.2 SUB-GROUP 2 (4 SAMPLES)
    - 3.2.2.2.1 INITIAL RF MEASUREMENTS - USE FINAL ELECTRICAL MEASUREMENTS FROM GROUP A.
    - 3.2.2.2.2 LIFE TEST – OPERATE SAMPLES UNITS FOR 1000 HRS AT 70°C AT INPUT POWER PER 1.1.6. ELECTRICAL MEASUREMENTS SHALL BE MADE AT 250 +48/-0 HRS, 500 +48/-0 HRS, AND 1000 +48/-0 HRS.
    - 3.2.2.2.3 FINAL RF MEASUREMENTS - MEASURE AND RECORD VSWR @ 1 GHZ AND ATTENUATION AT DC (0 GHZ) AND 1.0 GHZ.
- 3.2.3 GROUP C (QCI TESTING 4 SAMPLES APPROVED FROM GROUP A).
  - 3.2.3.1 LOAD LIFE TEST – BURN-IN UNITS AT 70°C WITH INPUT POWER PER 1.1.6 FOR A DURATION OF 1000 HOURS (1½ HOURS ON, ½ HOUR OFF). MEASURE AND RECORD ELECTRICALS AT 0, 250, 500, AND 1000 HOURS.
  - 3.2.3.2 AFTER LOAD LIFE RF MEASUREMENTS - MEASURE AND RECORD VSWR AND ATTENUATION AT 1 GHZ AT 25°C. TEST ACCEPTABLE LIMITS PER 4.2.1 OF TP-8965.
- 3.4 TEST DATA REQUIREMENTS:
  - 3.4.1 TEST DATA REQUIRED FOR CUSTOMER - SEE PARAGRAPH 5.0 OF TP-8965.
  - 3.4.2 DATA RETENTION - 24 MONTHS.
  - 3.4.3 TEST SAMPLES REQUIRED FOR CUSTOMER - SEE PARAGRAPH 5.0 OF TP-8965.

4.0 **PACKAGING:** STANDARD PACK PER MC0023. (SERIALIZED WAFFLE PACK)

EMC TECHNOLOGY 8851 SW OLD KANSAS AVE. STUART, FL 34997	<b>CAGE CODE # 24602</b>		<b>DWG #</b>	1009885000
	<b>CHANGE NOTICE</b>	EN 03-287	<b>REV LVL</b>	-
			<b>SHEET</b>	2 OF 3

PART ID REF  
HR03XXXS

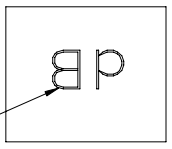
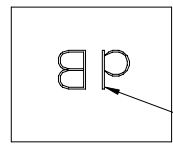
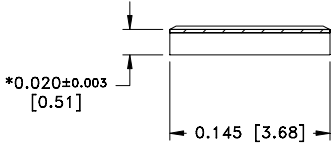
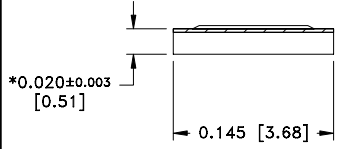
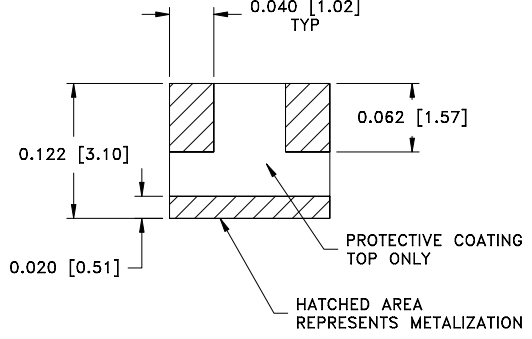
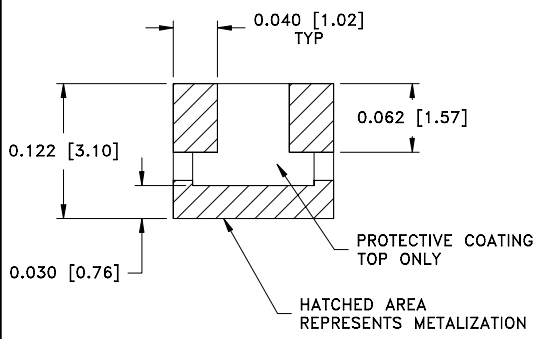

UNITS MARKED ON THIS SURFACE

1-10dB

11-20dB

**MECHANICAL SPECIFICATIONS:**

SUBSTRATE:  
MATERIAL - ALUMINA 96%, MIL-I-10.  
TERMINAL:  
MATERIAL - THICK FILM, NICKEL BARRIER,  
SOLDER FUSE COATED.  
RESISTIVE ELEMENT:  
MATERIAL - THIN FILM, TANTALUM NITRIDE.

METRIC EQUIVALENTS GIVEN IN [mm]  
FOR REFERENCE INFORMATION ONLY



\* DIMENSIONS APPLY BEFORE SOLDER, ALLOW 0.015 MAX FOR ALL PRETINNED SURFACES.

**POWER RATING AND DERATING**

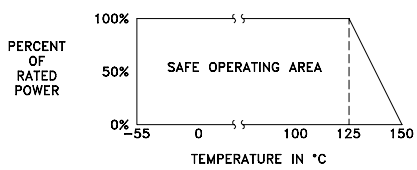

**EMC Technology**  
8851 SW OLD KANSAS AVE  
STUART, FL 34997  
PHONE NO. (772)286-9300  
FAX NO. (772)283-5286

UNLESS OTHERWISE SPECIFIED DIMENSIONS ARE IN INCHES  
**TOLERANCES**  
FRACT ---  
ANG ---  
XX ---  
XXX ±0.005  
XXXX ---

THESE DRAWINGS AND SPECIFICATIONS ARE THE PROPERTY OF EMC TECHNOLOGY INC AND SHALL NOT BE DUPLICATED OR USED AS BASIS FOR THE MANUFACTURE OR SALE OF PARTS OR DEVICES WITHOUT PERMISSION.

CAGE CODE	SCALE	DRAWN BY	CHECKED BY	APPROVED BY
24602	10:1	JG 12/5/03		
REV	CHANGE NOTICE	DRAWING NO	SHEET	
-	EN 03-287	1009885000	3 OF 3	