



DC COMPONENTS CO., LTD.
RECTIFIER SPECIALISTS

MP10005
THRU
MP1010

TECHNICAL SPECIFICATIONS OF SINGLE-PHASE SILICON BRIDGE RECTIFIER
VOLTAGE RANGE - 50 to 1000 Volts CURRENT - 10 Amperes

FEATURES

- * Surge overload rating: 200 Amperes peak
- * Low forward voltage drop
- * Small size: simple installation

MECHANICAL DATA

- * Case: Molded plastic with heatsink
- * Epoxy: UL 94V-0 rate flame retardant
- * Lead: MIL-STD-202E, Method 208 guaranteed
- * Polarity: Symbols molded or marked on body
- * Mounting position: Any
- * Weight: 6.1 grams

MAXIMUM RATINGS AND ELECTRICAL CHARACTERISTICS

Ratings at 25°C ambient temperature unless otherwise specified.
Single phase, half wave, 60Hz, resistive or inductive load.
For capacitive load, derate current by 20%.

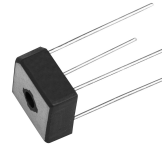

MP-6

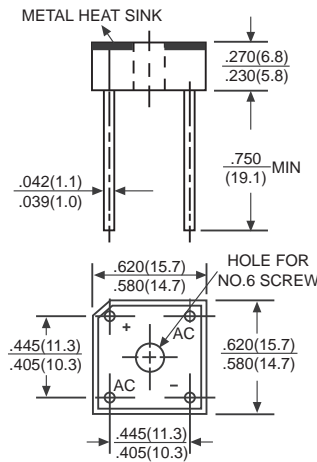

Dimensions in inches and (millimeters)

	SYMBOL	MP10005	MP1001	MP1002	MP1004	MP1006	MP1008	MP1010	UNITS	
Maximum Recurrent Peak Reverse Voltage	VRRM	50	100	200	400	600	800	1000	Volts	
Maximum RMS Bridge Input Voltage	VRMS	35	70	140	280	420	560	700	Volts	
Maximum DC Blocking Voltage	VDC	50	100	200	400	600	800	1000	Volts	
Maximum Average Forward Output Current at Tc = 50°C	IO	10							Amps	
Peak Forward Surge Current 8.3 ms single half sine-wave superimposed on rated load (JEDEC Method)	IFSM	200							Amps	
Maximum Forward Voltage Drop per element at 5.0A DC	VF	1.1							Volts	
Maximum DC Reverse Current at Rated DC Blocking Voltage per element	IR	@TA = 25°C	10							μAmps
		@Tc = 100°C	500							
Operating Temperature Range	TJ	-55 to +125							°C	
Storage Temperature Range	TSTG	-55 to +150							°C	

RATING AND CHARACTERISTIC CURVES (MP10005 THRU MP1010)

FIG. 1 - MAXIMUM NON-REPETITIVE FORWARD SURGE CURRENT

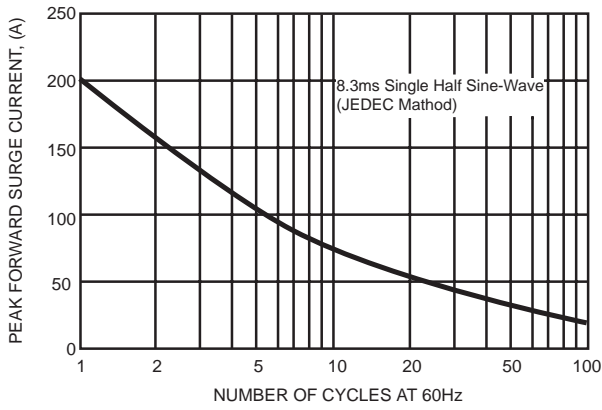

FIG. 2 - TYPICAL FORWARD CURRENT DERATING CURVE

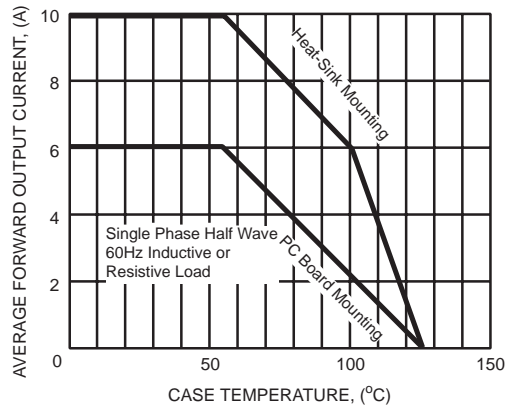

FIG. 3 - TYPICAL INSTANTANEOUS FORWARD CHARACTERISTICS

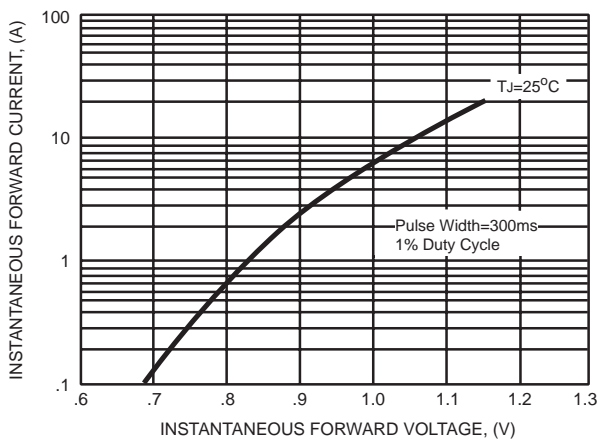

FIG. 4 - TYPICAL REVERSE CHARACTERISTICS

