

# INTERNATIONAL RECTIFIER

## 320PJT & 320PJT-A SERIES

### 1200 and 1400 Amp $I_{TGO}$ Gate Turn-Off Hockey Puck SCRs

#### Major Ratings and Characteristics

	320PJT200 320PJT250	320PJT200A 320PJT250A	Units
$I_{TGO}$	1200	1400	A
$I_T(RMS)$	500		A
$I_T(AV)$	320		A
@ Max. $T_C$	80		$^{\circ}C$
$I_{TSM}$ @ 50 Hz	4000		A
@ 60 Hz	4200		A
$I^2t$ @ 50 Hz	80,000		$A^2s$
@ 60 Hz	73,000		$A^2s$
$I_{GT}$	2.0		A
$dv/dt$	1000		$V/\mu s$
$di/dt$	500		$A/\mu s$
$t_{gq}$	20		$\mu s$
$T_J$	-40 to 125		$^{\circ}C$
$V_{RRM}, V_{DRM}$	2000 to 2500		V

#### Description/Features

The 320PJT Series of GTO (gate turn-off) thyristors is designed for power control applications such as uninterruptible power supplies (UPS), variable speed ac motor drives, etc. Since they can be turned off by a negative current pulse to the gate, devices in the 320PJT Series allow reductions in overall size, weight, cost and acoustical noise when compared to conventional thyristors that require bulky commutating circuits.

- 320A average current.
- 1200A and 1400A controllable on-state current.
- Maximum turn-off time of 20  $\mu s$ .
- Critical  $dv/dt$  of 1000  $V/\mu s$ .
- Available with maximum repetitive peak off-state voltage ( $V_{DRM}$ ) to 2500V.

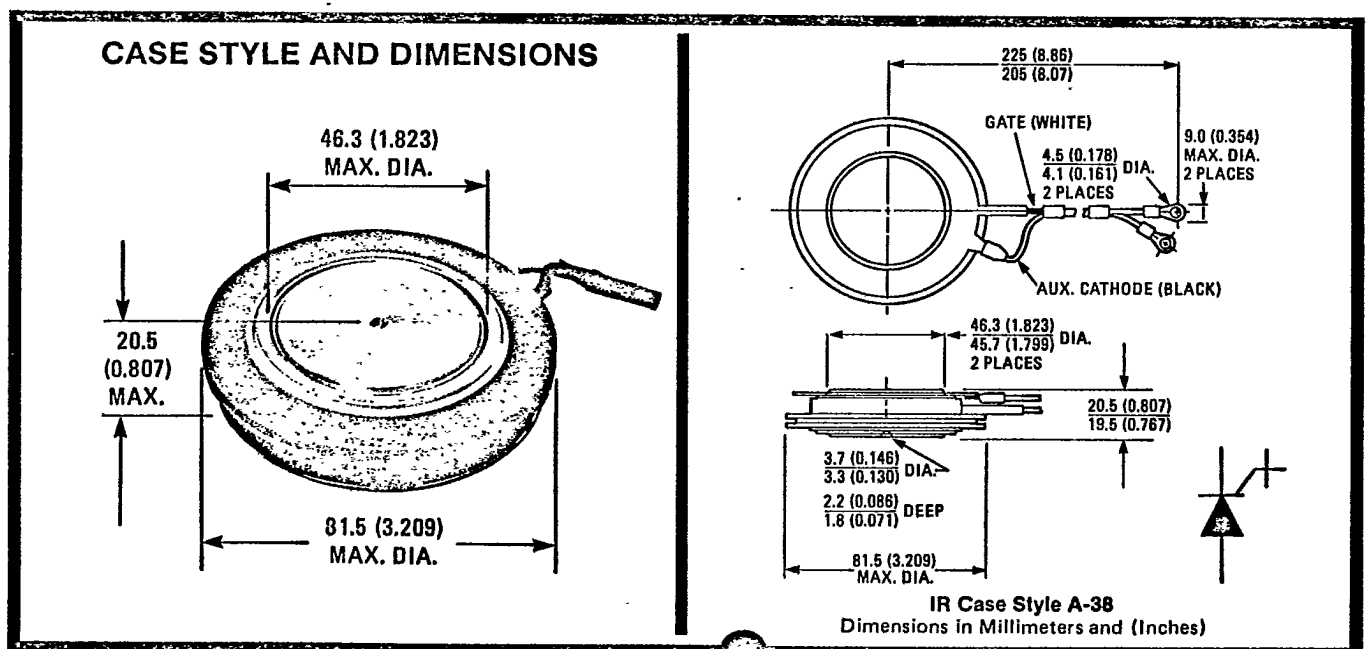

## 320PJT &amp; 320PJT-A Series

## VOLTAGE RATINGS

Part Number	V <sub>RRM</sub> , V <sub>DRM</sub> – Max. Repetitive Peak Reverse and Off-State Voltage (V) ① ②	V <sub>RSM</sub> – Max. Non-Repetitive Peak Reverse Voltage t <sub>p</sub> ≤ 5 ms (V) ②	V <sub>DSM</sub> – Max. Non-Repetitive Peak Off-State Voltage t <sub>p</sub> ≤ 5 ms (V) ①
	T <sub>J</sub> = -40 to 125°C	T <sub>J</sub> = 25 to 125°C	T <sub>J</sub> = 25 to 125°C
320PJT200	2000	2200	2200
① 320PJT200A	2000	2200	2200
320PJT250	2500	2750	2500
② 320PJT250A	2500	2750	2500

Peak off-state voltages apply for -2V or more negative gate voltage or for gate-to-cathode resistance = 2 ohms.

Peak reverse voltages apply for zero or negative gate voltage.

## ELECTRICAL SPECIFICATIONS

		320PJT200 320PJT250	320PJT200A 320PJT250A	Units	Conditions
<b>ON-STATE</b>					
I <sub>T</sub> (RMS)	Nominal RMS on-state current	500		A	
I <sub>T</sub> (AV)	Max. average on-state current @ Max. T <sub>C</sub>	320		A	180° half sine wave conduction.
		80		°C	
I <sub>TGQ</sub>	Max. controllable peak on-state current	1200	1400	A	T <sub>J</sub> = 125°C, V <sub>DM</sub> = 0.5 V <sub>DRM</sub> , G <sub>GQ</sub> = 5, C <sub>S</sub> = 3 μF. Note: V <sub>S</sub> ≤ 1000V @ T <sub>J</sub> = 25°C and V <sub>S</sub> ≤ 900V @ T <sub>J</sub> = 125°C. (V <sub>S</sub> is the voltage spike which appears on the dynamic on-state voltage trace during fall time.) ③
I <sub>TSM</sub>	Max. peak one cycle, non-repetitive surge current	4000		A	50 Hz half cycle sine wave or 6 ms rectangular pulse 60 Hz half cycle sine wave or 5 ms rectangular pulse Following any rated load condition, and with rated V <sub>RRM</sub> applied following surge. SCR turned fully on.
		4200			
I <sup>2</sup> <sub>t</sub>	Max. I <sup>2</sup> <sub>t</sub> capability for fusing	80,000		A <sup>2</sup> s	t = 10 ms Rated V <sub>RRM</sub> applied following surge, initial T <sub>J</sub> ≤ 125°C. t = 8.3 ms
		73,000			
V <sub>TM</sub>	Max. peak on-state voltage	3.23		V	T <sub>J</sub> = 25°C, I <sub>T</sub> (AV) = 320A (1000A peak) and I <sub>G</sub> = 4A
I <sub>L</sub>	Typical latching current	30		A	T <sub>J</sub> = 25°C
I <sub>H</sub>	Typical holding current	30		A	T <sub>J</sub> = 25°C
<b>BLOCKING</b>					
dv/dt	Min. critical rate-of-rise of off-state voltage	1000		V/μs	Gate voltage = -2V Gate-to-cathode resistance = 2Ω T <sub>J</sub> = 125°C, V <sub>D</sub> = 0.5 V <sub>DRM</sub>
		300			
I <sub>DM</sub> & I <sub>RM</sub>	Max. peak off-state and reverse current	100		mA	T <sub>J</sub> = 125°C, V <sub>DM</sub> = rated V <sub>DRM</sub> . Peak off-state current applies for -2V or more negative gate voltage or for gate-to-cathode resistance = 2Ω.
<b>SWITCHING</b>					
di/dt	Max. repetitive rate-of-rise of turned-on current	500		A/μs	di <sub>G</sub> /dt ≥ 10A/μs, + I <sub>GM</sub> ≥ 15A, V <sub>D</sub> ≤ 0.5 V <sub>DRM</sub> , I <sub>TM</sub> ≤ 1200A (320PJT200 & 250), I <sub>TM</sub> ≤ 1400A (320PJT200A & 250A).
t <sub>d</sub>	Max. delay time	5		μs	T <sub>J</sub> = 125°C, V <sub>D</sub> = 0.5 V <sub>DRM</sub> , + I <sub>GM</sub> = 15A, di <sub>G</sub> /dt = 10A/μs, I <sub>T</sub> = 1200A (320PJT200, 250), I <sub>T</sub> = 1400A (320PJT200A, 250A).
t <sub>gt</sub>	Max. turn-on time	10		μs	t <sub>gt</sub> is measured from the instant at which i <sub>G</sub> = 0.1 I <sub>GM</sub> to the instant at which v <sub>D</sub> = 0.1 V <sub>D</sub> with resistive load. T <sub>J</sub> = 125°C, V <sub>D</sub> = 0.5 V <sub>DRM</sub> , + I <sub>GM</sub> = 15A, di <sub>G</sub> /dt = 10 A/μs, I <sub>T</sub> = 1200A (320PJT200 & 250), I <sub>T</sub> = 1400A (320PJT200A & 250A).

$$\textcircled{3} G_{GQ} = \frac{I_T}{\text{applied } I_{GQ}} = \text{forced turn-off gain.}$$



## ELECTRICAL SPECIFICATIONS (Continued)

		320PJT200 320PJT250	320PJT200A 320PJT250A	Units	Conditions
SWITCHING (Continued)					
$t_{on}$	Min. permissible on-time	20		$\mu s$	$t_{on}$ is the time necessary to ensure that all cathode islands are in conduction. $T_J = 125^\circ C$ , $V_D = 0.5 V_{DRM}$ , $I_{GM} = 15A$ , $di_G/dt = 10 A/\mu s$ , $I_T = 1200A$ (320PJT200 & 250), $I_T = 1400A$ (320PJT200A & 250A).
$t_{gq}$	Max. gate-controlled turn-off time	20		$\mu s$	$t_{gq}$ is measured from the instant at which $i_G = 0.1 I_{GQ}$ to the instant at which $i_T = 0.1 I_{TGQ}$ with resistive load. $T_J = 125^\circ C$ , $V_D = 0.5 V_{DRM}$ , $di_G/dt = 60 A/\mu s$ , $V_{GK} = -18V$ , $I_T = 1200A$ (320PJT200 & 250), $I_T = 1400A$ (320PJT200A & 250A).
$t_f$	Typical fall time	1.0		$\mu s$	$t_f$ is measured from the instant at which $i_T = 0.9 I_{TGQ}$ to the instant at which $i_T = 0.1 I_{TGQ}$ with resistive load. $T_J = 125^\circ C$ , $V_D = 0.5 V_{DRM}$ , $di_G/dt = 60 A/\mu s$ , $V_{GK} = -18V$ , $I_T = 1200A$ (320PJT200 & 250), $I_T = 1400A$ (320PJT200A & 250A).
$t_{off}$	Min. permissible off-time	85		$\mu s$	$t_{off}$ is measured from the instant at which the turn-off pulse is applied to the gate to the earliest instant at which the GTO can be retriggered. $T_J = 125^\circ C$ , $V_D = 0.5 V_{DRM}$ , $di_G/dt = 60 A/\mu s$ , $V_{GK} = -18V$ , $I_T = 1200A$ (320PJT200 & 250), $I_T = 1400A$ (320PJT250A & 250A).
$Q_{CQ}$	Typical gate turn-off charge	2200	2500	$\mu C$	$T_J = 125^\circ C$ , $V_D = 0.5 V_{DRM}$ , $di_G/dt = 60 A/\mu s$ , $V_{GK} = -18V$ , $I_T = 1200A$ (320PJT200 & 250), $I_T = 1400A$ (320PJT200A & 250A).
TRIGGERING					
$P_{GF(AV)}$	Max. average forward gate power	30		W	$t_p \leq 5 \mu s$ Forward gate power is produced by positive gate current, reverse gate power is produced by negative gate current.
$P_{GRM}$	Max. peak reverse gate power	18,000		W	
$P_{GR(AV)}$	Max. average reverse gate power	80		W	
$+I_{GM}$	Max. peak positive gate current	100		A	$t_p \leq 100 \mu s$ . Positive gate current may not be applied during reverse recovery interval.
$-I_{GM}$	Max. peak negative gate current	50		mA	$T_J = 125^\circ C$ , $-V_{GM} = \text{rated } -V_{GRM}$ . SCR blocking.
$-V_{GRM}$	Max. repetitive peak negative gate voltage	20		V	SCR blocking.
$I_{GT}$	Max. required DC gate current to trigger	4.6		A	$T_C = -40^\circ C$
		2.0			$T_C = 25^\circ C$
		0.5			$T_C = 125^\circ C$
$V_{GT}$	Max. required DC gate voltage to trigger	1.25		V	$T_C = -40^\circ C$
		1.0			$T_C = 25^\circ C$

## THERMAL-MECHANICAL SPECIFICATIONS

$T_J$	Junction operating temperature range	-40 to 125		$^\circ C$	
$T_{stg}$	Storage temperature range	-40 to 125		$^\circ C$	
$R_{thJC}$	Max. internal thermal resistance, junction-to-case	0.035		deg. C/W	DC operation; double side cooled, mounting force = 11750N (2650 lbf).
$R_{thCS}$	Thermal resistance, one pole piece to one heat dissipator	0.02		deg. C/W	Mounting surface smooth, flat and greased.
F	Mounting force	Min.	10,600 (2400)	N (lbf)	
		Max.	12,900 (2900)		
wt	Approximate weight	360 (12.7)		g (oz.)	
	Case Style	IR: A-38			

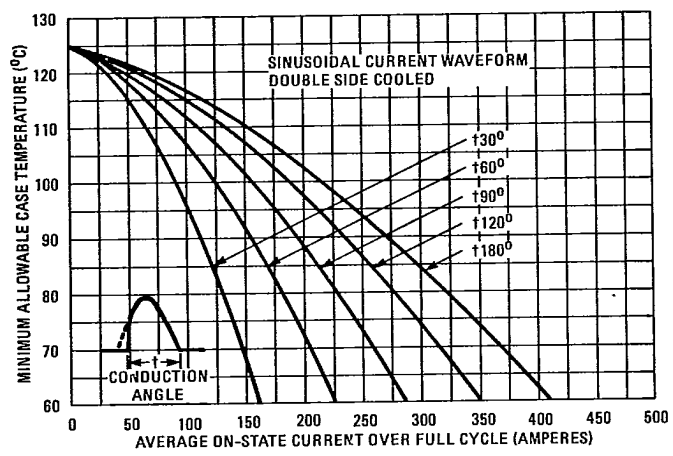

**Fig. 1 - Maximum Allowable Case Temperature Vs. Average On-State Current (Sinusoidal Current Waveform), All Devices**

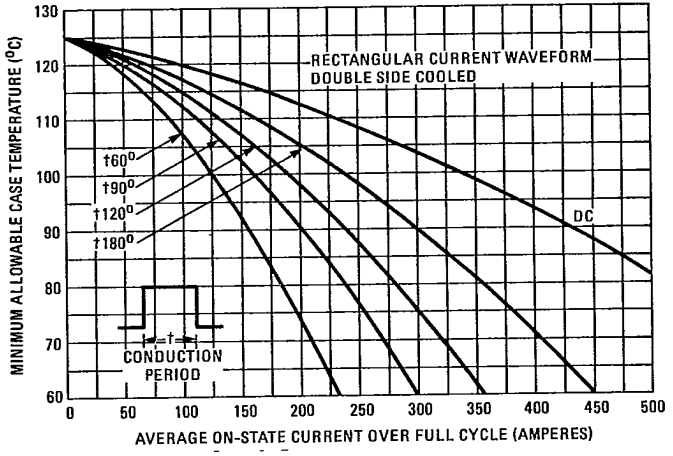

**Fig. 2 - Maximum Allowable Case Temperature Vs. Average On-State Current (Rectangular Current Waveform), All Devices**

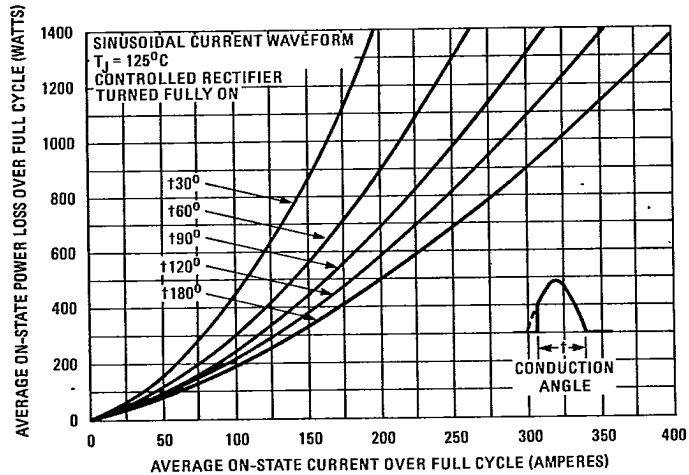

**Fig. 3 - Maximum Low-Level On-State Power Loss Vs. Average On-State Current (Sinusoidal Current Waveform), All Devices**

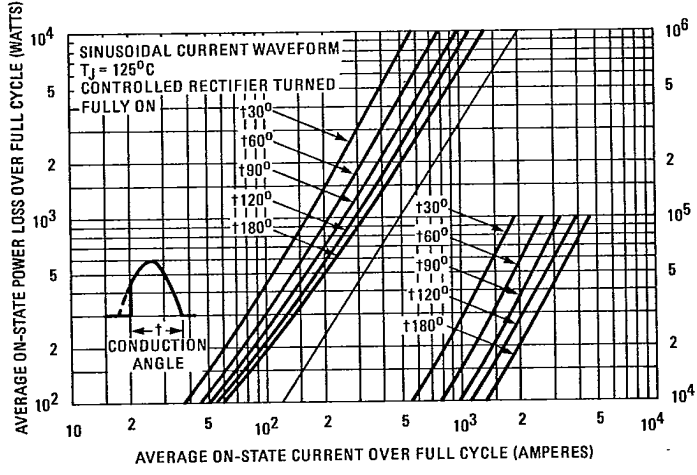

**Fig. 4 - Maximum High-Level On-State Power Loss Vs. Average On-State Current (Sinusoidal Current Waveform), All Devices**

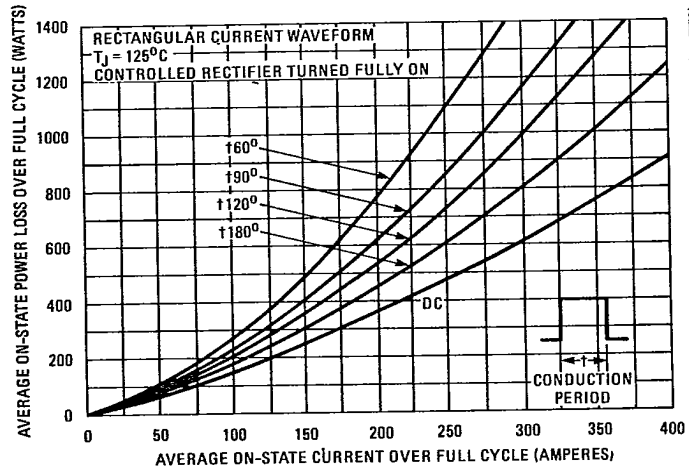

**Fig. 5 - Maximum Low-Level On-State Power Loss Vs. Average On-State Current (Rectangular Current Waveform), All Devices**

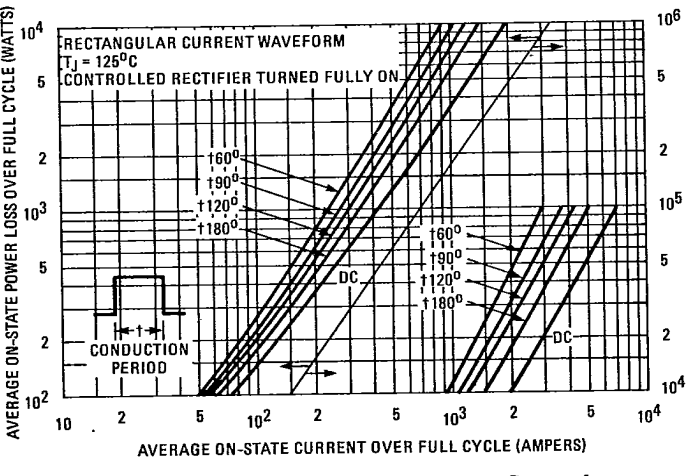

**Fig. 6 - Maximum High-Level On-State Power Loss Vs. Average On-State Current (Rectangular Current Waveform), All Devices**

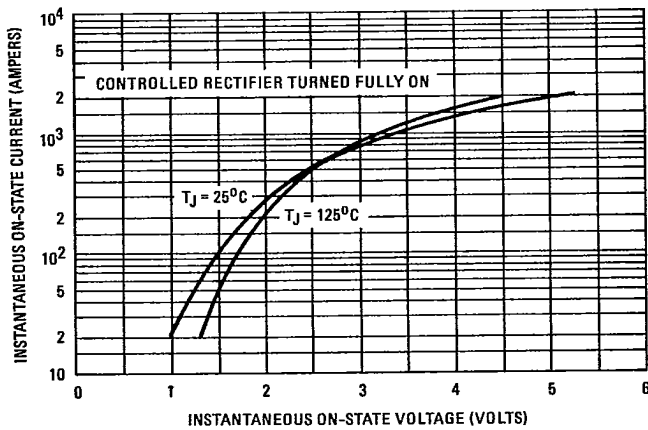

Fig. 7 - Maximum Instantaneous On-State Voltage Vs. Instantaneous On-State Current, All Devices

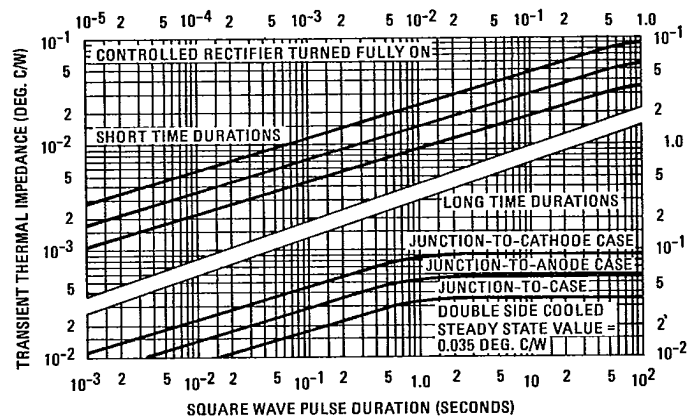

Fig. 8 - Maximum Transient Thermal Impedance Vs. Square Wave Pulse Duration, All Devices

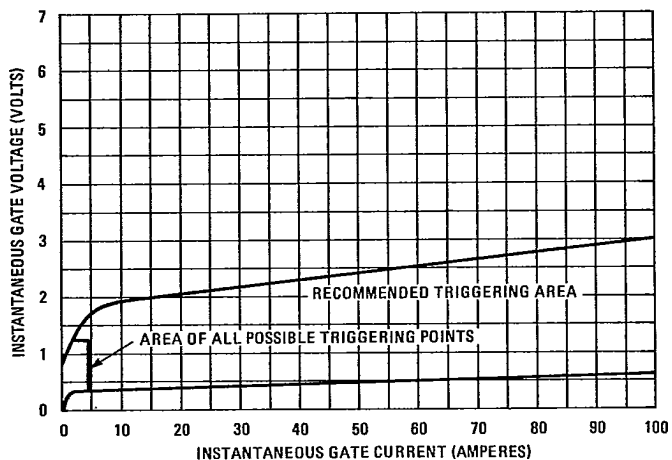

Fig. 9 - Gate Characteristics, All Devices

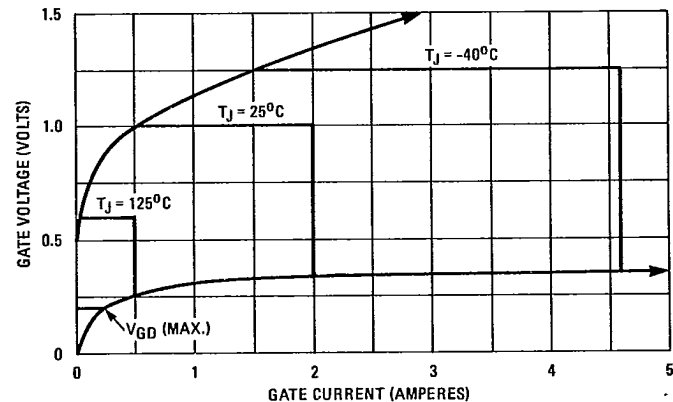

Fig. 9a - Areas of All Possible Triggering Points, All Devices

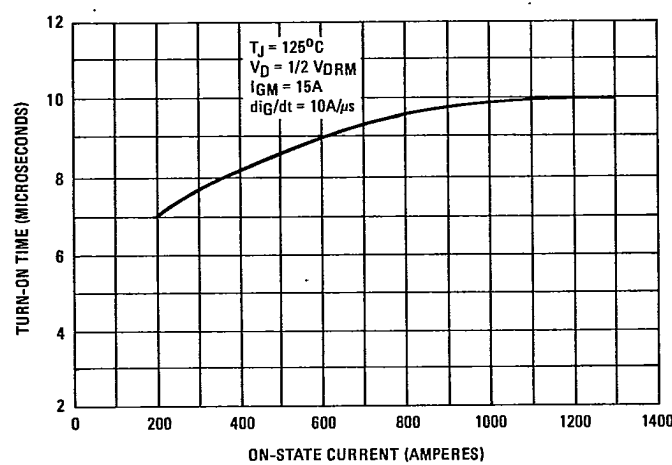

Fig. 10 - Turn-On Time Vs. On-State Current, All Devices

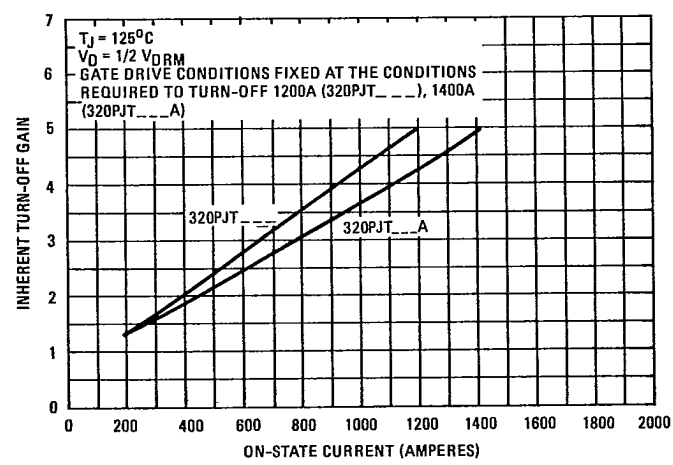

Fig. 11 - Typical Inherent Turn-Off Gain Vs. Instantaneous On-State Current, All Devices

320PJT & 320PJT-A Series

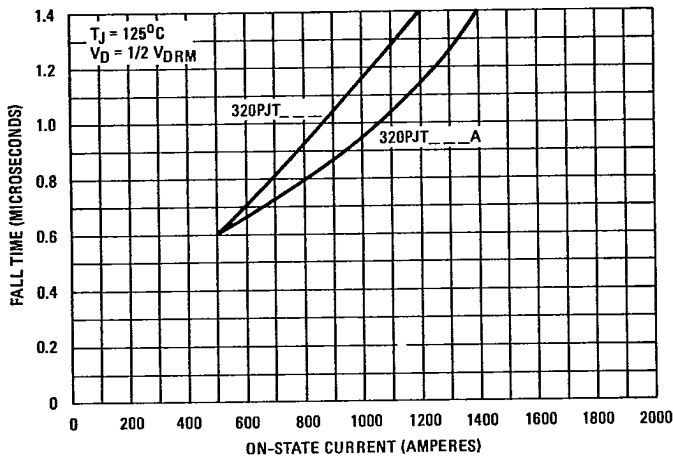

Fig. 12 – Typical Fall Time Vs. On-State Current, All Devices

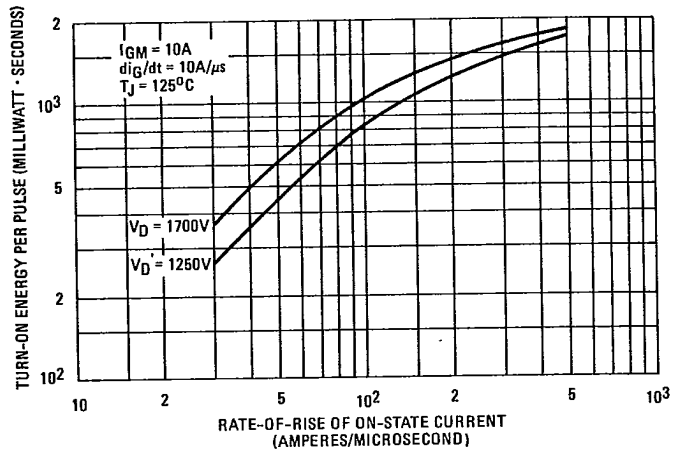

Fig. 13 – Maximum Turn-On Energy Per Pulse Vs. Rate-of-Rise of On-State Current, All Devices

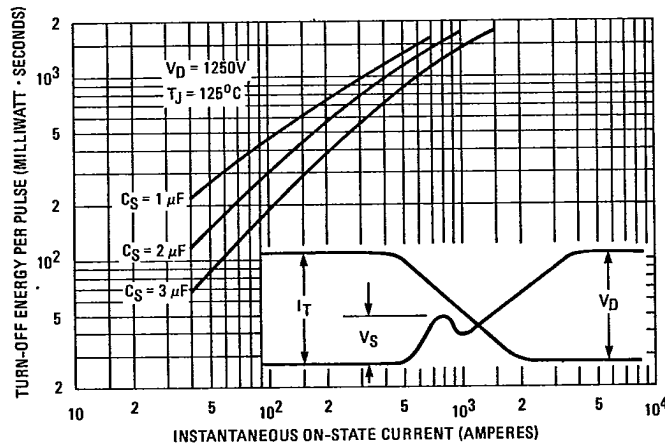

Fig. 14 – Maximum Turn-Off Energy Per Pulse Vs. On-State Current, All Devices

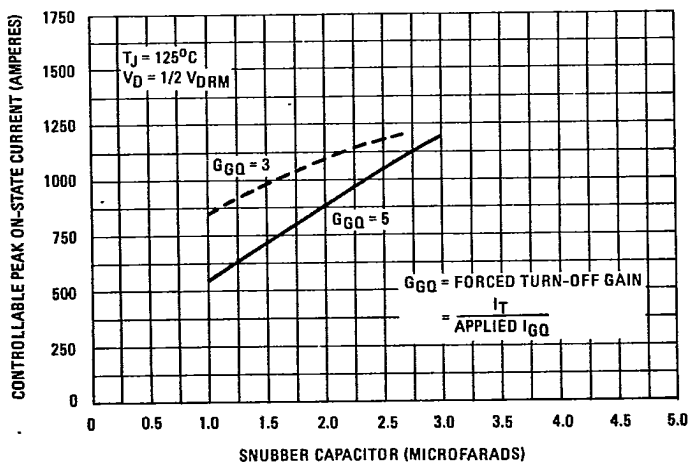

Fig. 15 – Maximum Controllable Peak On-State Current Vs. Snubber Capacitor Value, 320PJT200 & 320PJT250

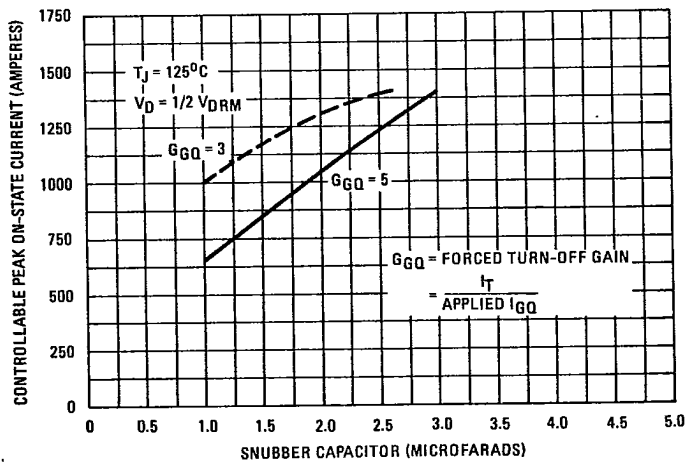

Fig. 16 – Maximum Controllable Peak On-State Current Vs. Snubber Capacitor Value, 320PJT200A & 320PJT250A

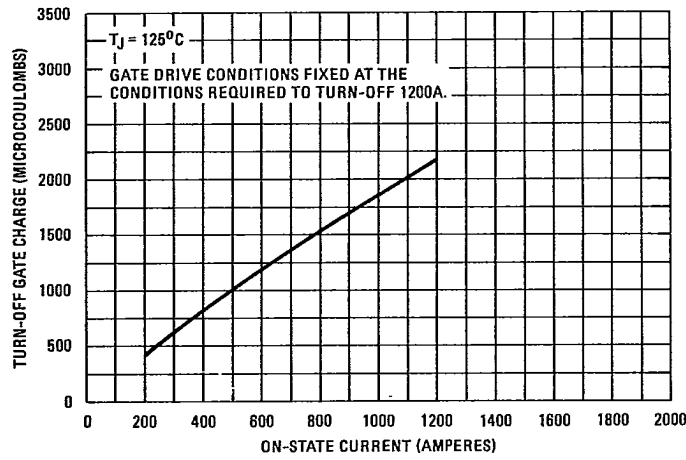

Fig. 17 – Typical Turn-Off Gate Charge Vs. On-State Current, 320PJT200 & 320PJT250

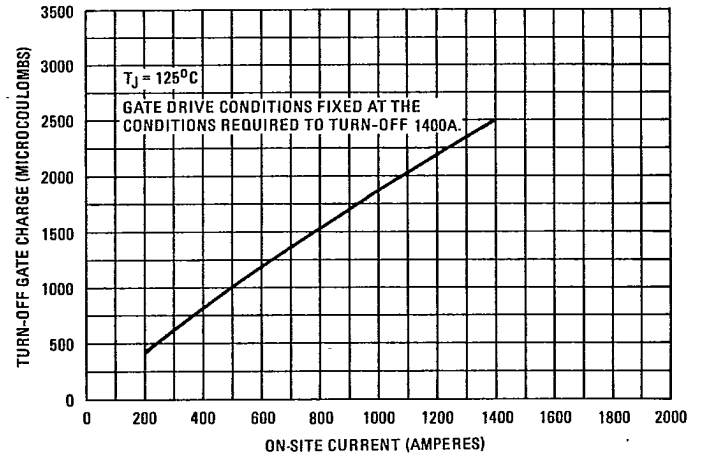

Fig. 18 – Typical Turn-Off Gate Charge Vs. On-State Current, 320PJT200A & 320PJT250A

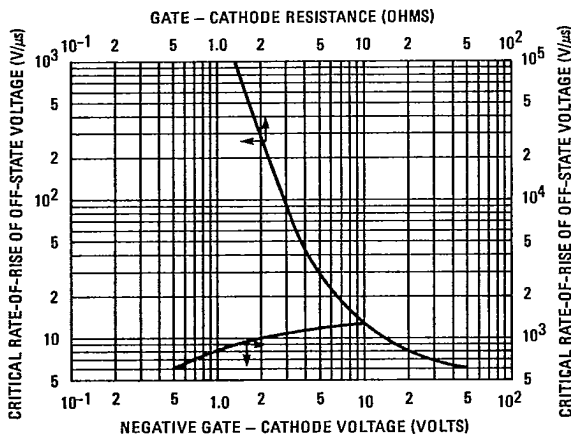

Fig. 19 – Minimum Critical Rate-of-Rise of Off-State Voltage Vs. Negative Gate-Cathode Voltage and Vs. Gate-Cathode Resistance, All Devices

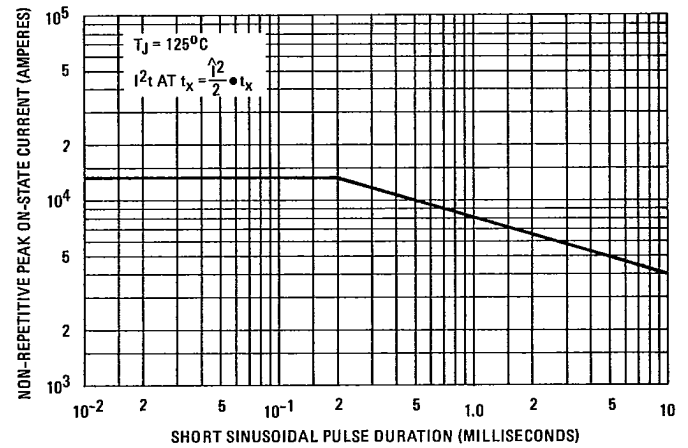
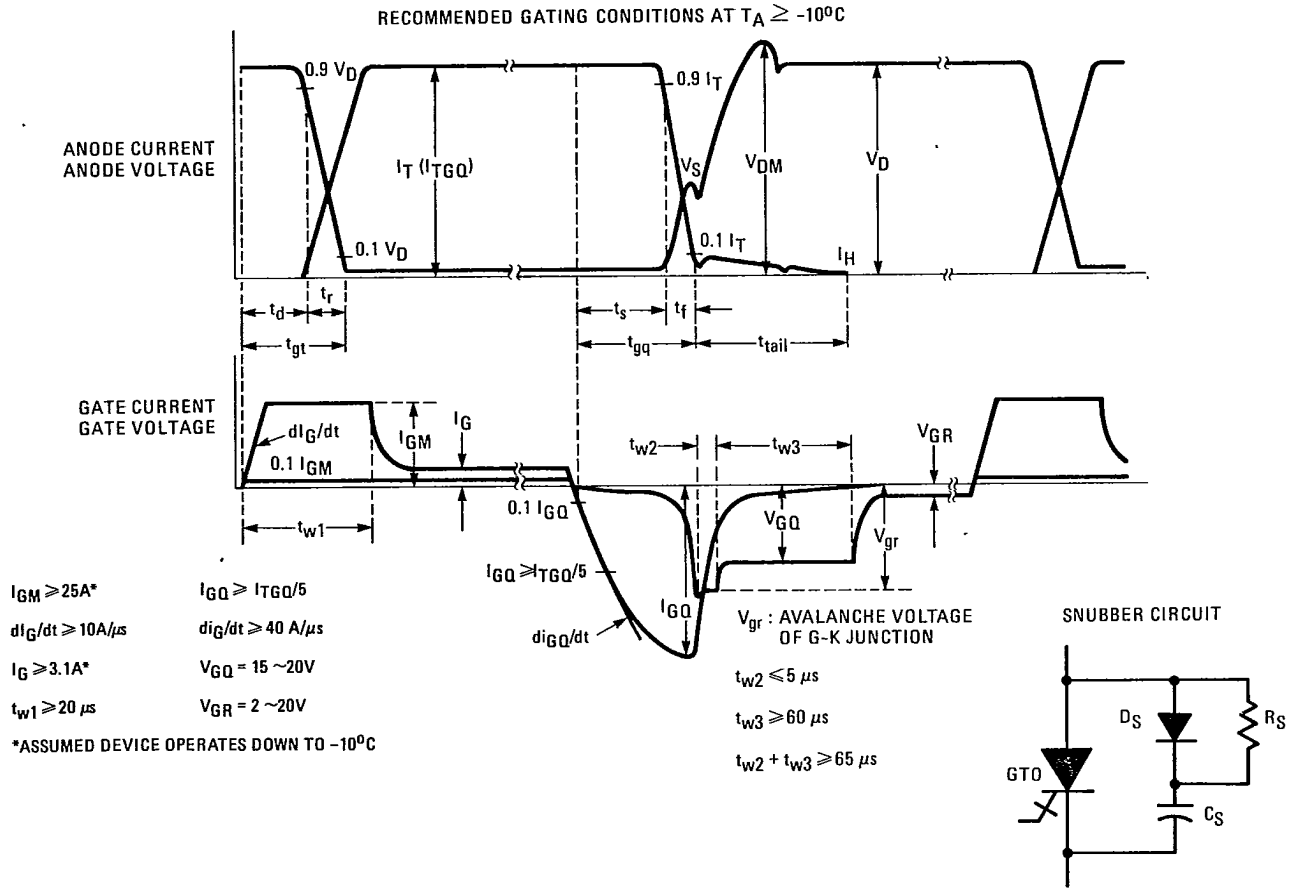

Fig. 20 – Non-Repetitive Peak On-State Current Vs. Sinusoidal Pulse Duration, All Devices



SNUBBER CAPACITOR $C_s$ ( $\mu\text{F}$ )	SNUBBER RESISTOR $R_s$ ( $\Omega$ )	MINIMUM ON-TIME ( $\mu\text{s}$ )
3.0	20	150
	10	90
2.0	20	100
	10	60
1.0	20	50
	10	30

Fig. 21 — Recommended Gating Conditions