

isc Silicon NPN Power Transistor

2SD1345

DESCRIPTION

- High Switching Time
- Low Collector Saturation Voltage
: $V_{CE(sat)} = 0.4V(\text{Max}) @ I_C = 4A$
- Wide Area of Safe Operation
- Complement to Type 2SB983

APPLICATIONS

- Inverters, converters
- Controllers for DC motor, pulse motor
- Switching power supplies
- General power applications

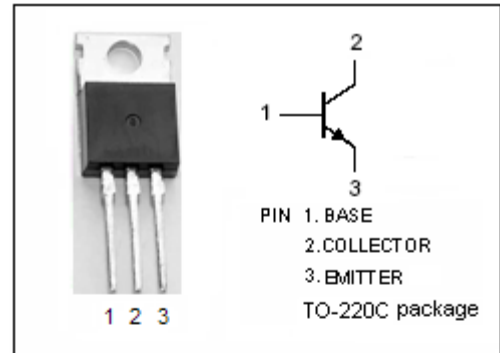

ABSOLUTE MAXIMUM RATINGS($T_a=25^\circ\text{C}$)

SYMBOL	PARAMETER	VALUE	UNIT
V_{CBO}	Collector-Base Voltage	60	V
V_{CEO}	Collector-Emitter Voltage	50	V
V_{EBO}	Emitter-Base Voltage	6	V
I_C	Collector Current-Continuous	7	A
I_{CM}	Collector Current-Peak	12	A
I_B	Base Current-Continuous	1.5	A
I_{BM}	Base Current-Peak	4	A
P_C	Total Power Dissipation @ $T_C=25^\circ\text{C}$	40	W
T_J	Junction Temperature	150	$^\circ\text{C}$
T_{stg}	Storage Temperature Range	-55~150	$^\circ\text{C}$

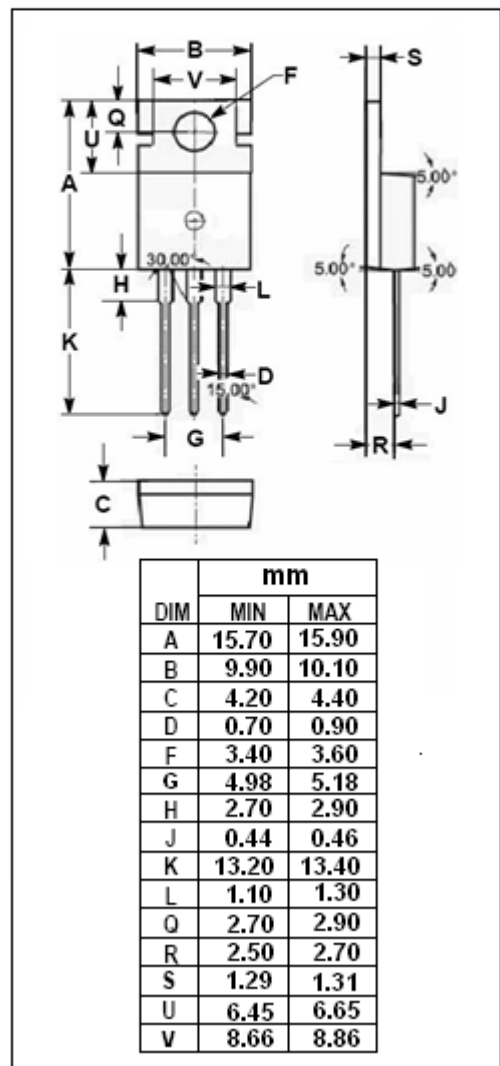

THERMAL CHARACTERISTICS

SYMBOL	PARAMETER	MAX	UNIT
$R_{th\ j-c}$	Thermal Resistance, Junction to Case	3.1	$^\circ\text{C/W}$

isc Silicon NPN Power Transistor

2SD1345

ELECTRICAL CHARACTERISTICS

 $T_C=25^{\circ}\text{C}$ unless otherwise specified

SYMBOL	PARAMETER	CONDITIONS	MIN	TYP.	MAX	UNIT
$V_{(BR)CEO}$	Collector-Emitter Breakdown Voltage	$I_C=1\text{mA}; I_B=0$	50			V
$V_{CE(sat)}$	Collector-Emitter Saturation Voltage	$I_C=4\text{A}; I_B=0.4\text{A}$			0.4	V
$V_{BE(sat)}$	Base-Emitter Saturation Voltage	$I_C=4\text{A}; I_B=0.4\text{A}$			1.2	V
I_{CBO}	Collector Cutoff Current	$V_{CB}=40\text{V}; I_E=0$			0.1	mA
I_{CEO}	Collector Cutoff Current	$V_{CE}=40\text{V}; I_B=0$			0.1	mA
I_{EBO}	Emitter Cutoff Current	$V_{EB}=4\text{V}; I_C=0$			0.1	mA
h_{FE-1}	DC Current Gain	$I_C=1\text{A}; V_{CE}=2\text{V}$	70		200	
h_{FE-2}	DC Current Gain	$I_C=5\text{A}; V_{CE}=2\text{V}$	30			
f_T	Current-Gain—Bandwidth Product	$I_C=1\text{A}; V_{CE}=5\text{V}$		10		MHz

Switching times

t_{on}	Turn-on Time	$R_L=10\Omega, V_{BB2}=-5\text{V}$ $I_C=2\text{A}; I_{B1}=-I_{B2}=0.2\text{A}$		0.2		μs
t_{stg}	Storage Time			0.9		μs
t_f	Fall Time			0.3		μs