

500V N-Channel MOSFET

TG430

DESCRIPTION

These N-Channel enhancement mode power field effect transistors are produced using Fairchild’s proprietary, planar stripe, DMOS technology.

This advanced technology has been especially tailored to minimize on-state resistance, provide superior switching performance, and withstand high energy pulse in the avalanche and commutation mode. These devices are well suited for high efficiency switch mode power supply.

ABSOLUTE MAXIMUM RATINGS (Ta = 25 °C)

| Parameter | I | Value | Unit |
|-------------------------------------|-----------|----------|------|
| Drain-Source Voltage | V_{DSS} | 500 | V |
| Drain Current - Continuous | I_D | 4.5 | A |
| Drain Current - Pulsed | I_{DM} | 18 | A |
| Gate-Source Voltage | V_{GSS} | ± 30 | V |
| Power Dissipation | P_D | 85 | W |
| Max. Operating Junction Temperature | T_j | 150 | °C |
| Storage Temperature | T_{stg} | -55~150 | °C |

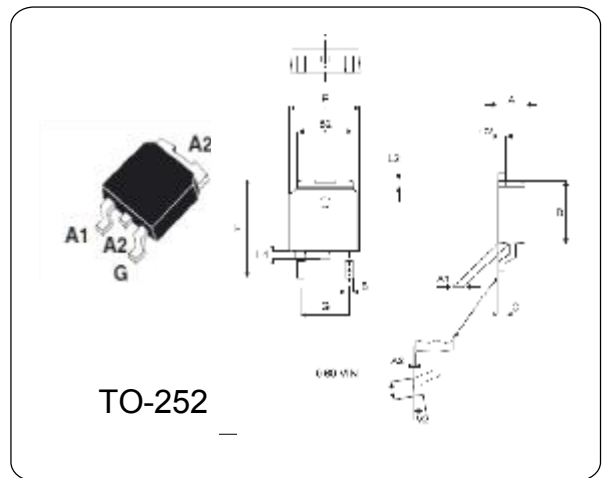

ELECTRICAL CHARACTERISTICS (Ta = 25 °C)

| Parameter | Symbol | Test Conditions | Min. | Typ. | Max. | Unit |
|------------------------------------|--------------|------------------------------------|------|------|------|----------|
| Drain-Source Breakdown Voltage | BV_{DSS} | $V_{GS} = 0V, I_D = 250 \mu A$ | 500 | — | — | V |
| Zero Gate Voltage Drain Current | I_{DSS} | $V_{DS} = 500V, V_{GS} = 0V$ | — | — | 1.0 | μA |
| Gate-Body Leakage Current, Forward | I_{GSSF} | $V_{GS} = 30V, V_{DS} = 0V$ | — | — | 100 | nA |
| Gate-Body Leakage Current, Reverse | I_{GSSR} | $V_{GS} = -30V, V_{DS} = 0V$ | — | — | -100 | nA |
| Gate Threshold Voltage | $V_{GS(th)}$ | $V_{DS} = V_{GS}, I_D = 250 \mu A$ | 3.0 | — | 5.0 | V |
| Static Drain-Source On-Resistance | $R_{DS(on)}$ | $V_{GS} = 10 V, I_D = 2.25 A$ | — | 1.36 | 1.8 | Ω |
| Drain-Source Diode Forward Voltage | V_{SD} | $V_{GS} = 0 V, I_S = 4.5 A$ | — | — | 1.4 | V |