

NOTES: UNLESS OTHERWISE SPECIFIED

1. FOR GENERAL SERIES SPECIFICATIONS, SEE SD45-0000.
2. MATERIAL SPECIFICATIONS:
 FRONT BODY: COPPER ALLOY
 INSULATOR: TEFLON PER ASTM D1710
 ALL OTHER METAL PARTS: BRASS PER ASTM B16
3. FINISH SPECIFICATIONS:
 BODY: .000015 MIN. GOLD PER ASTM B488 OVER .000080 MIN. NICKEL PER AMS-QQN-290.
 CONTACT: .000030 MIN. GOLD PER ASTM B488 OVER .000080 MIN. NICKEL PER AMS-QQN-290.
 CAP: .000005 MIN. GOLD PER ASTM B488 OVER .000080 MIN. NICKEL PER AMS-QQN-290.
4. ELECTRICAL SPECIFICATIONS:
 FREQUENCY RANGE: DC TO 6GHz
 VSRW: TBD
5. CAP, AND DISC SHIPPED LOOSE.
6. FOR USE WITH .085 SEMI-RIGID CABLE OR EQUIVALENT.
7. FOR ASSEMBLY SEE CAP5-08 WITH TRIMMING DIMENSIONS AS SHOWN.

REV	DESCRIPTION	BY DATE	APPD
A	ER6192	PSM 01/23/08	DCgm

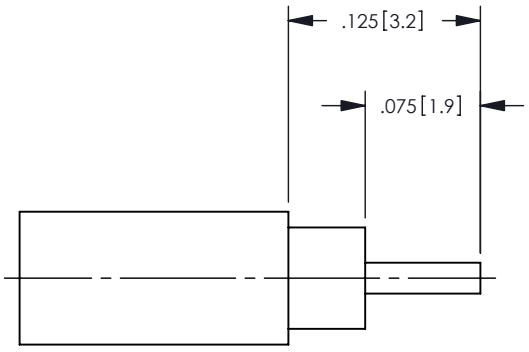
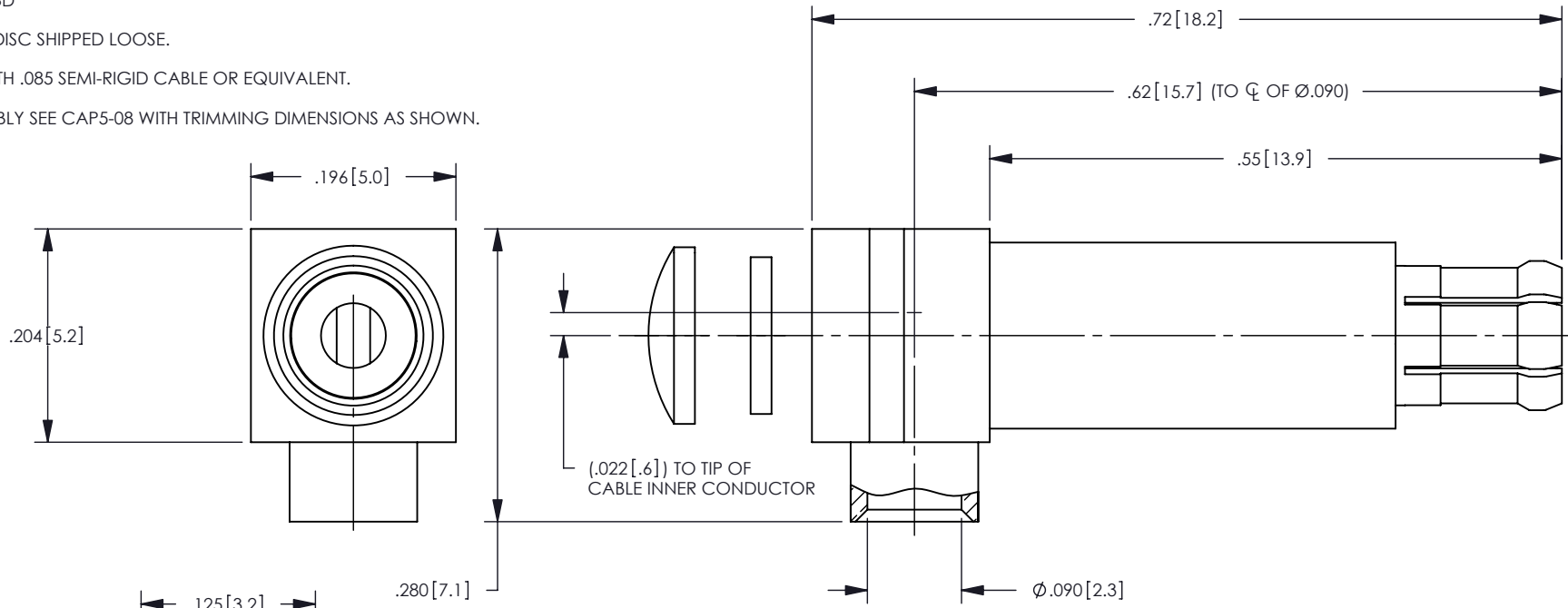

CABLE TRIMMING DIMENSIONS

CATALOG P/N: 452-500-0853H

PER ASME Y14.5M-1994 UNLESS OTHERWISE SPECIFIED: DIMENSIONS ARE IN INCHES [MM] TOLERANCES: DECIMAL: .XX ± .01 [0.3] .XXX ± .005 [0.13] .XXXX ± .XXXX ANGLES: ± 2° SCALE: 6:1				 Winchester Electronics Corporation 62 Barnes Industrial Road North Wallingford, Connecticut 06492	
CUSTOMER SALES DRAWING			 MCX EXTENDED RIGHT ANGLE PLUG		
DRAWN	DATE	APPROVED	DATE	A SD452-500-0853H SHT 1 OF 1	REV A
JED	03/16/01	JWH	03/20/01		
APPROVED	DATE	APPROVED	DATE		
JEM	03/20/01	WPM	01/24/08		