

### 1. Mechanical Dimensions:

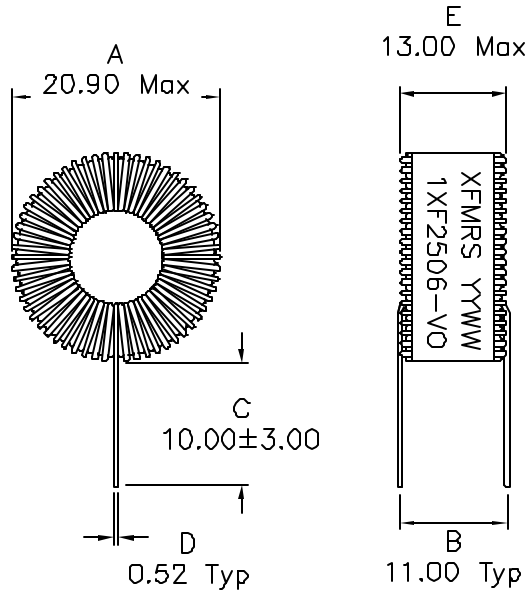

### 2. Schematic:

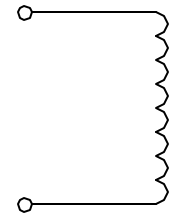

### 3. Electrical Specifications:

Inductance: 250.90uH±20% @100KHz, 250mV  
 DC Res.: 0.221 Ohms Max  
 DC Current: 1.9A (Based on 30°C Temp. Rise)  
 Isat: 2.2A (30% drop in OCL Typical)  
 ET Constant: 47.8 V-uS  
 Energy Storage: 421uJ  
 Q: 10 Min @100KHz 250mV

**Notes:**

1. Solderability: Leads shall meet MIL-STD-202G, Method 208H for solderability.
2. Flammability: UL94V-0
3. ASTM oxygen index: > 28%
4. Insulation System: Class F 155°C. UL file E151556
5. Operating Temperature Range: All listed parameters are to be within tolerance from -40°C to +75°C
6. Storage Temperature Range: -55°C to +105°C
7. Aqueous wash compatible
8. Electrical and mechanical specifications 100% tested
9. RoHS Compliant Component

DOC. REV. A/2

<b>XFMRS Inc</b> www.XFMRS.com	Title: Toroid Inductor		
	UNLESS OTHERWISE SPECIFIED TOLERANCES: .xxx ±0.25 Dimensions in mm	P/N: 1XF2506-VO	REV. A
SHEET 1 OF 1	DWN.	Feng	Dec-20-10
	CHK.	YK Liao	Dec-20-10
	APP.	Joe Huff	Dec-20-10