

■ BLOCK DIAGRAM

●R1230DXX1A/B

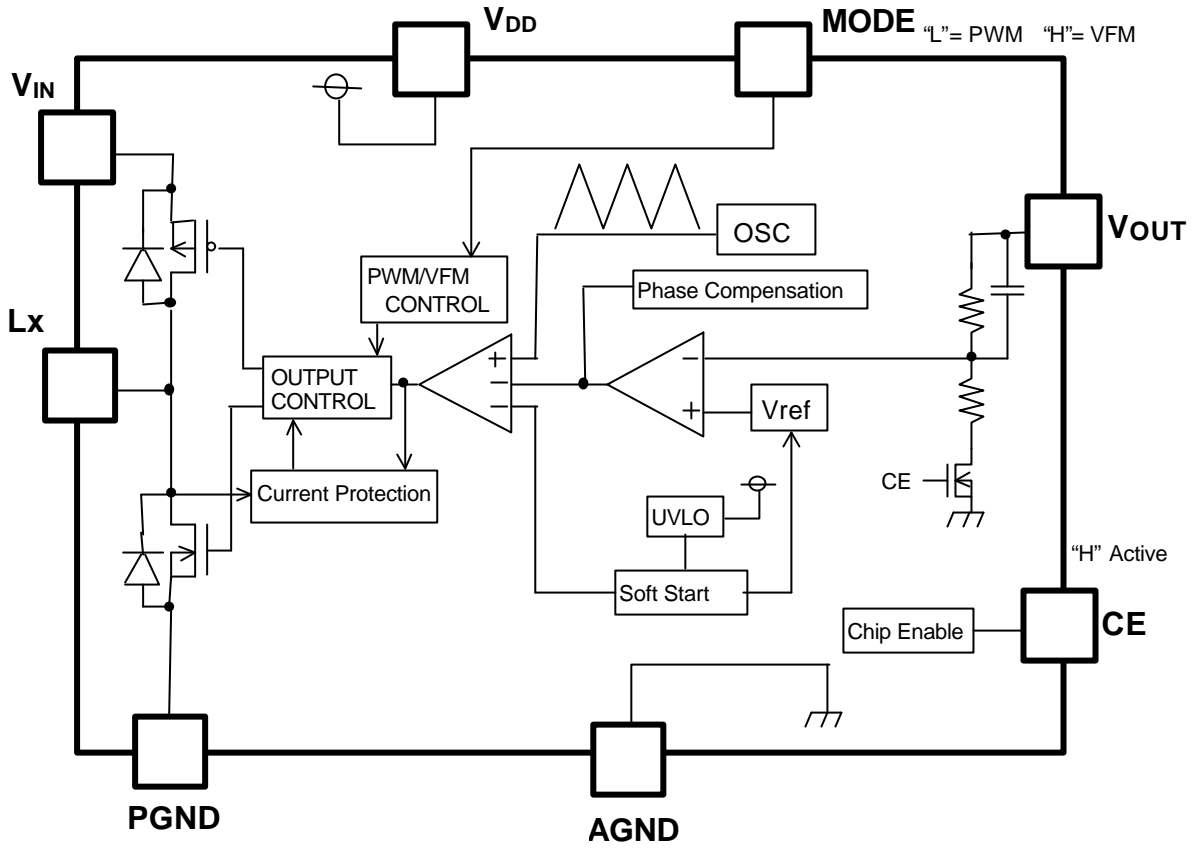

●R1230D001C/D

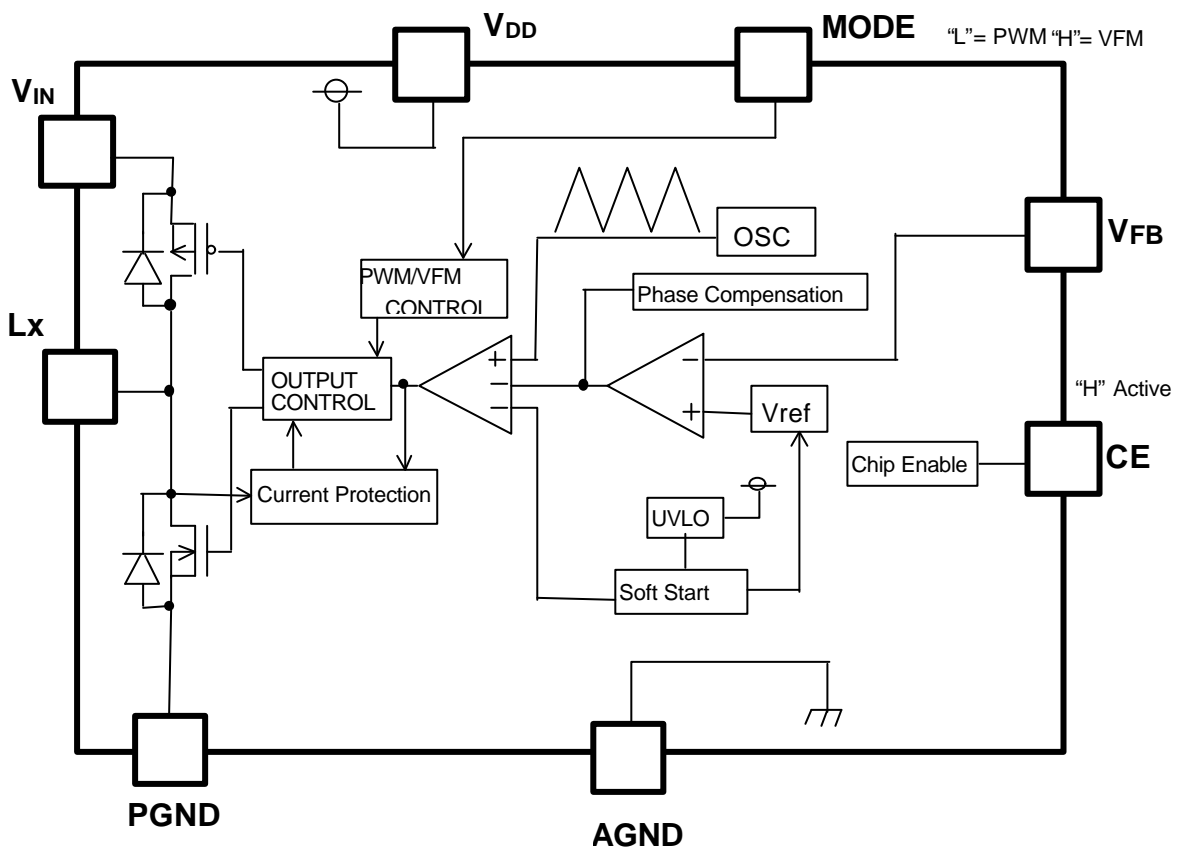

SELECTION GUIDE

In the R1230D Series, the output voltage, the oscillator frequency, and the taping type for the ICs can be selected at the user's request.

The selection can be made by designating the part number as shown below;

R1230DXXXX-XX
 ↑ ↑ ↑ ↑
 a b c d

Code	Contents
a	Setting Output Voltage(V _{OUT}): Stepwise setting with a step of 0.1V in the range of 1.2V to 3.3V is possible for A/B version. "00" is for Output Voltage Adjustable C/D version
b	1 : fixed
c	Designation of Optional Function A : 500kHz, Fixed Output Voltage B : 800 kHz, Fixed Output Voltage C : 500kHz, Adjustable Output Voltage D : 800kHz, Adjustable Output Voltage
d	Designation of Taping Type; Ex. :TR,TL(refer to Taping Specification) "TR" is prescribed as a standard.

PIN CONFIGURATION

● SON-8

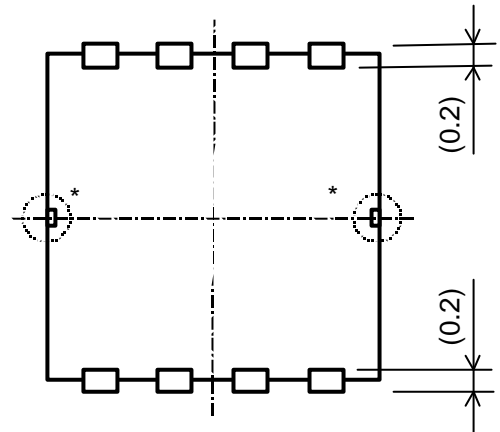
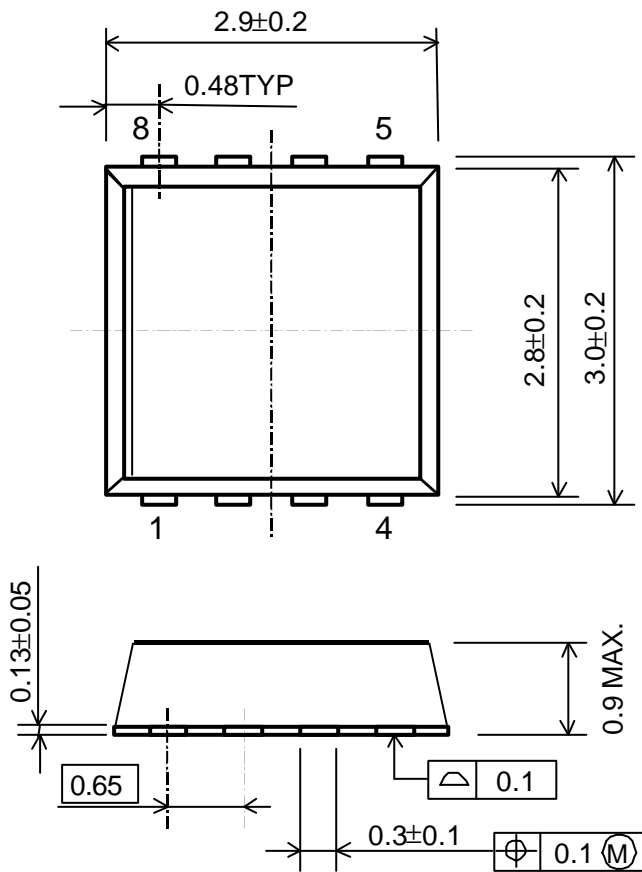

*Attention : Tab suspension leads in the  parts have GND level. (They are connected to the reverse side of this IC.) Do not connect to other wires or land patterns.

Unit : mm

■ PIN DESCRIPTION

Pin No.	Symbol	Description
1	VIN	Voltage Supply Pin
2	PGND	Ground Pin
3	VDD	Voltage Supply Pin
4	CE	Chip Enable Pin (active with "H")
5	VOUT/VFB	Output/Feedback Pin
6	MODE	Mode changer Pin (PWM mode at "L", VFM mode at "H".)
7	AGND	Ground Pin
8	Lx	Lx Pin

■ ABSOLUTE MAXIMUM RATINGS

(AGND=PGND=0V)

Symbol	Item	Rating	Unit
VIN	VIN Supply Voltage	6.5	V
VDD	VDD Pin Voltage	6.5	V
VLX	Lx Pin Voltage	-0.3~VIN+0.3	V
VCE	CE Pin Input Voltage	-0.3~VIN+0.3	V
VMODE	MODE Pin Input Voltage	-0.3~VIN+0.3	V
VFB	VFB Pin Input Voltage	-0.3~VIN+0.3	V
ILX	LX Pin Output Current	-0.8	A
PD	Power Dissipation	300	mW
Topt	Operating Temperature Range	-40~+85	°C
Tstg	Storage Temperature Range	-55~+125	°C

■ ELECTRICAL CHARACTERISTICS

●R1230D**1A/B

(T_{opt}=25°C)

Symbol	Item	Conditions	MIN.	TYP.	MAX.	Unit
V _{IN}	Operating Input Voltage		2.4		5.5	V
V _{OUT}	Step-down Output Voltage	V _{IN} =V _C E=V _{SET} +1.5V, V _{MODE} =0V, I _{OUT} =10mA	TYP.× 0.980	V _{SET}	TYP.× 1.020	V
ΔV _{OUT} / ΔT	Step-down Output Voltage Temperature Coefficient	-40°C ≤ T _{opt} ≤ 85°C		±150		ppm/°C
f _{osc}	Oscillator Frequency(xx1A)	V _{IN} =V _C E=V _{SET} +1.5V	425	500	575	kHz
f _{osc}	Oscillator Frequency(xx1B)	V _{IN} =V _C E=V _{SET} +1.5V	680	800	920	kHz
I _{DD}	Supply Current(xx1A)	V _{IN} =V _C E=V _{SET} +1.5V, V _{OUT} =V _{MODE} =0V		230	300	μA
I _{DD}	Supply Current(xx1B)	V _{IN} =V _C E=V _{SET} +1.5V, V _{OUT} =V _{MODE} =0V		250	350	μA
I _{stb}	Standby Current	V _{IN} =5.5V, V _C E=V _{OUT} =0V		0	5	μA
R _{ONP}	ON Resistance of Pch Transistor	V _{IN} =5.0V	0.20	0.35	0.60	Ω
R _{ONN}	ON Resistance of Nch Transistor	V _{IN} =5.0V	0.20	0.45	0.70	Ω
I _{LXleak}	Lx Leakage Current	V _{IN} =5.5V, V _C E=0V, V _{LX} =0V/5.5V	-0.1	0.0	0.1	μA
I _{VOUT}	V _{OUT} Leakage Current	V _{IN} =5.5V, V _C E=0V, V _{LX} =0V/5.5V	-0.1	0.0	0.1	μA
I _{CE}	CE Input Current	V _{IN} =5.5V, V _{MODE} =0V, V _C E=5.5V/0V	-0.1	0.0	0.1	μA
V _{CEH}	CE "H" Input Voltage	V _{IN} =5.5V, V _{OUT} =0V	1.5			V
V _{CEL}	CE "L" Input Voltage	V _{IN} =2.4V, V _{OUT} =0V			0.3	V
Maxdty	Oscillator Maximum Duty Cycle	V _{MODE} =0V	100			%
V _{LX}	Lx Limit Voltage	V _{MODE} = V _{OUT} =0V, V _{IN} =V _C E=3.0V	V _{IN} -0.15	V _{IN} - 0.35	V _{IN} - 0.55	V
T _{start}	Delay Time by Soft-Start function	at no load, V _{IN} =V _C E=V _{SET} +1.5V	0.5	1.5	2.5	ms
T _{prot}	Delay Time for protection circuit	V _{IN} =V _C E=V _{SET} +1.5V, V _{MODE} =0V	0.5	1.5	2.5	ms
V _{UVLO1}	UVLO Threshold Voltage	V _{IN} =V _C E=2.5V->1.5V, V _{OUT} =0V	1.8	2.1	2.2	V
V _{UVLO2}	UVLO Released Voltage	V _{IN} =V _C E=1.5V->2.5V, V _{OUT} =0V	1.9	2.2	2.3	V
I _{MODE}	MODE Pin Input Current	V _{IN} =5.5V, V _C E=0V, V _{MODE} =5.5V/0V	-0.1		0.1	μA
V _{MODEH}	MODE "H" Input Voltage	V _{IN} =V _C E=5.5V, V _{OUT} =0V	1.5			V
V _{MODEL}	MODE "L" Input Voltage	V _{IN} =V _C E=2.4V, V _{OUT} =0V			0.3	V
V _{FMDty}	VFM Duty Cycle	V _{IN} =V _C E= V _{MODE} =2.4V, V _{OUT} =0V	55	65	85	%

●R1230D001C/D

(T_{opt}=25°C)

Symbol	Item	Conditions	MIN.	TYP.	MAX.	Unit
V _{IN}	Operating Input Voltage		2.4		5.5	V
V _{FB}	Feedback Voltage	V _{IN} =V _{CE} =V _{SET} +1.5V, V _{MODE} =0V, I _{OUT} =10mA	0.776	0.800	0.824	V
ΔV _{FB} /ΔT	Feedback Voltage Temperature Coefficient	-40°C ≤ T _{opt} ≤ 85°C		±150		ppm/°C
f _{osc}	Oscillator Frequency(xx1C)	V _{IN} =V _{CE} =V _{SET} +1.5V	425	500	575	kHz
f _{osc}	Oscillator Frequency(xx1D)	V _{IN} =V _{CE} =V _{SET} +1.5V	680	800	920	kHz
I _{DD}	Supply Current(xx1C)	V _{IN} =V _{CE} =5.5V, V _{FB} =V _{MODE} =0V		230	300	μA
I _{DD}	Supply Current(xx1D)	V _{IN} =V _{CE} =5.5V, V _{FB} =V _{MODE} =0V		250	350	μA
I _{stb}	Standby Current	V _{IN} =5.5V, V _{CE} =V _{FB} =0V		0	5	μA
R _{ONP}	ON Resistance of Pch Transistor	V _{IN} =5.0V	0.20	0.35	0.60	Ω
R _{ONN}	ON Resistance of Nch Transistor	V _{IN} =5.0V	0.20	0.45	0.70	Ω
I _{LXleak}	Lx Leakage Current	V _{IN} =5.5V, V _{CE} =0V, V _{LX} =0V/5.5V	-0.1	0.0	0.1	μA
I _{VFB}	VFB Leakage Current	V _{IN} =5.5V, V _{CE} =0V, V _{FB} =0V/5.5V	-0.1	0.0	0.1	μA
I _{CE}	CE Input Current	V _{IN} =5.5V, V _{MODE} =0V, V _{CE} =5.5V/0V	-0.1	0.0	0.1	μA
V _{CEH}	CE "H" Input Voltage	V _{IN} =5.5V, V _{FB} =0V	1.5			V
V _{CEL}	CE "L" Input Voltage	V _{IN} =2.4V, V _{FB} =0V			0.3	V
Maxdty	Oscillator Maximum Duty Cycle	V _{MODE} =0V	100			%
V _{LX}	Lx Limit Voltage	V _{IN} =V _{CE} =3.0V, V _{MODE} =0V, V _{FB} =0V	V _{IN} -0.15	V _{IN} -0.35	V _{IN} -0.55	V
T _{start}	Delay Time by Soft-Start function	at no load, V _{IN} =V _{CE} =V _{SET} +1.5V	0.5	1.5	2.5	ms
T _{prot}	Delay Time for protection circuit	V _{IN} =V _{CE} =3.6V, V _{MODE} =0V		1.5		ms
V _{UVLO1}	UVLO Threshold Voltage	V _{IN} =V _{CE} =2.5V->1.5V, V _{FB} =0V	1.8	2.1	2.2	V
V _{UVLO2}	UVLO Released Voltage	V _{IN} =V _{CE} =1.5V->2.5V, V _{FB} =0V	1.9	2.2	2.3	V
I _{MODE}	MODE Pin Input Current	V _{IN} =5.5V, V _{MODE} =5.5V/0V, V _{CE} =0V	-0.1		0.1	μA
V _{MODE}	MODE "H" Input Voltage	V _{IN} =V _{CE} =5.5V, V _{FB} =0V	1.5			V
V _{MODEL}	MODE "L" Input Voltage	V _{IN} =V _{CE} =2.4V, V _{FB} =0V			0.3	V
V _{FMDty}	VFM Duty Cycle	V _{IN} =V _{CE} =V _{MODE} =2.4V, V _{FB} =0V	55	65	85	%

■ TEST CIRCUITS

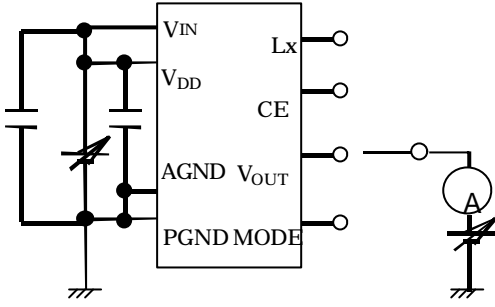

Test Circuit for Input Current and Leakage Current

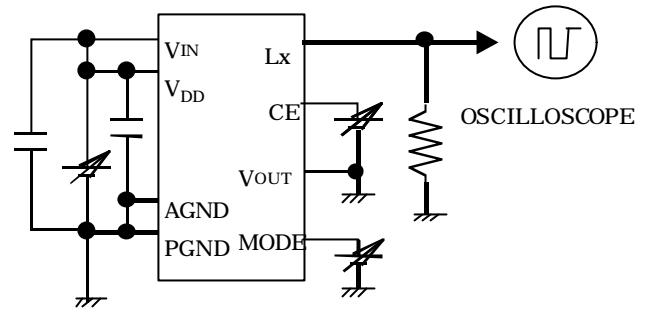

Test Circuit for Input Voltage and UVLO voltage

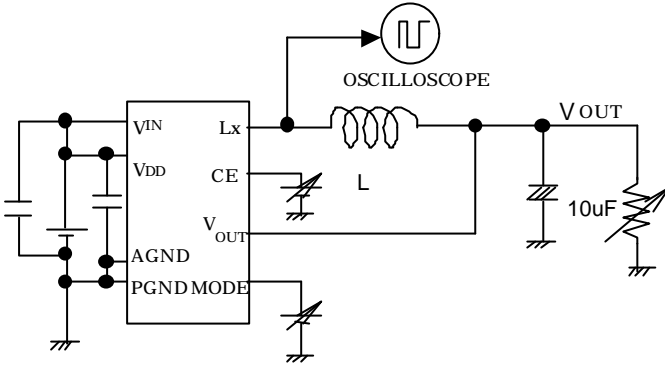

Test Circuit for Output Voltage, Oscillator Frequency, Soft-Starting Time

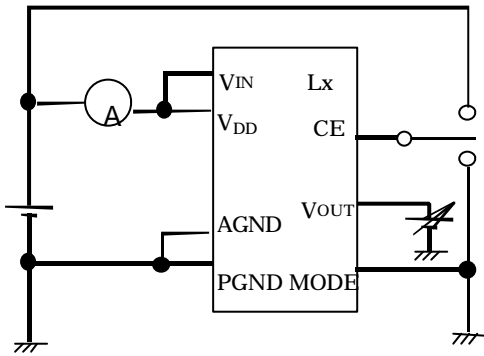

Test Circuit for Supply Current and Standby Current

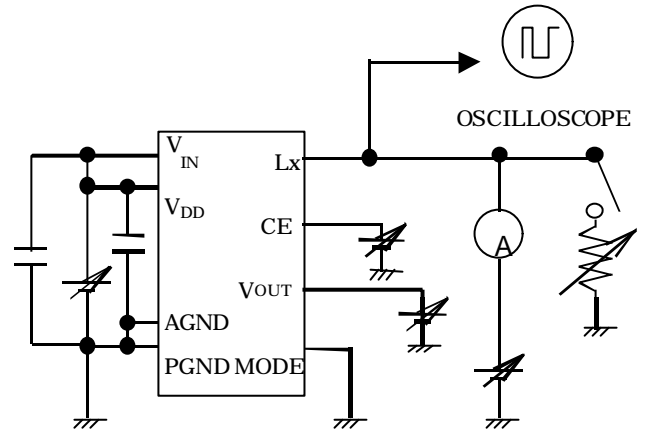

Test Circuit for ON resistance of Lx, Limit Voltage, Delay Time of Protection Circuit

The bypass capacitor between the power supply and GND is a ceramic capacitor, 10µF.

■ TYPICAL APPLICATION AND TECHNICAL NOTES

1) Fixed Output Voltage Type

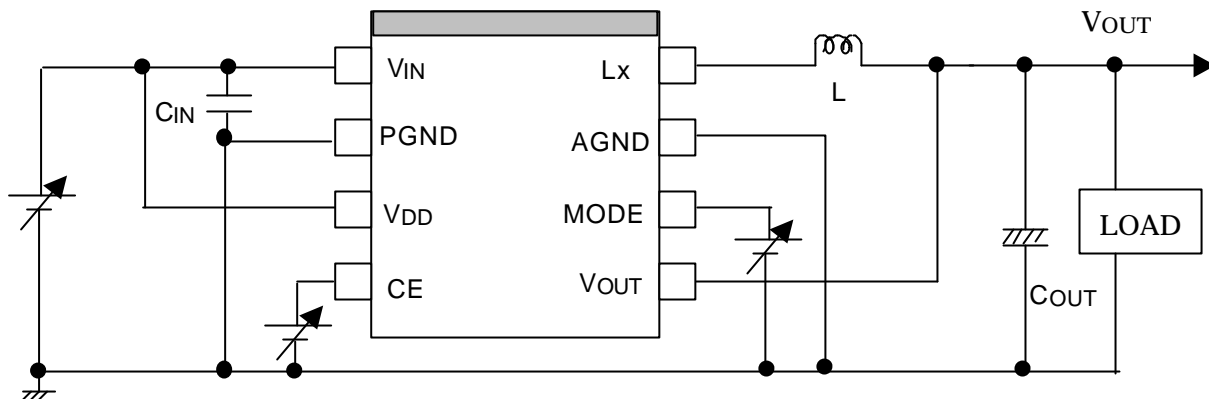

L : 10 μ H LQH3C100K54 (Murata)
 COUT: 10 μ F ECSTOJX106R (Panasonic)
 CIN : 10 μ F C3216JBOJ106M (TDK)

2) Adjustable Output Voltage Type

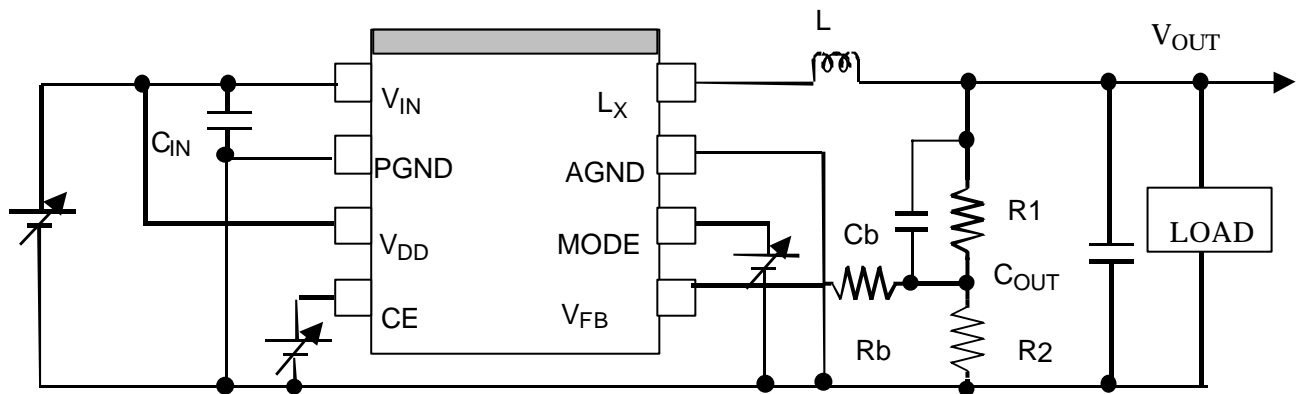

L : 10 μ H LQH3C100K54 (Murata)
 COUT: 10 μ F ECSTOJX106R (Panasonic)
 CIN : 10 μ F C3216JBOJ106M (TDK)

As for how to choose Cb, Rb, R1, and R2 values, refer to the technical notes.

When you use these ICs, consider the following issues;

- Input same voltage into Power Supply pins, VIN and VDD. Set the same level as AGND and PGND.
- When you control the CE pin and MODE pin by another power supply, do not make its "H" level more than the voltage level of VIN / VDD pin.
- Set external components such as an inductor, CIN, COUT as close as possible to the IC, in particular, minimize the wiring to VIN pin and PGND pin.
- At stand by mode, (CE="L"), the Lx output is Hi-Z, or both P-channel transistor and N-channel transistor of Lx pin turn off.
- Use an external capacitor COUT with a capacity of 10 μ F or more, and with good high frequency characteristics such as tantalum capacitors.
- At VFM mode, (MODE="H"), Latch protection circuit does not operate.
- If the mode is switched over into PWM mode from VFM mode during the operation, change the mode at light load current. If the load current us large, output voltage may decline.

RICOH

- Reinforce the V_{IN} , $PGND$, and V_{OUT} lines sufficiently. Large switching current may flow in these lines. If the impedance of V_{IN} and $PGND$ lines is too large, the internal voltage level in this IC may shift caused by the switching current, and the operation might be unstable.

☆ The performance of power source circuits using these ICs extremely depends upon the peripheral circuits. Pay attention in the selection of the peripheral circuits. In particular, design the peripheral circuits in a way that the values such as voltage, current, and power of each component, PCB patterns and the IC do not exceed their respected rated values.

■ OPERATION of step-down DC/DC converter and Output Current

The step-down DC/DC converter charges energy in the inductor when L_x transistor is ON, and discharges the energy from the inductor when L_x transistor is OFF and controls with less energy loss, so that a lower output voltage than the input voltage is obtained. The operation will be explained with reference to the following diagrams:

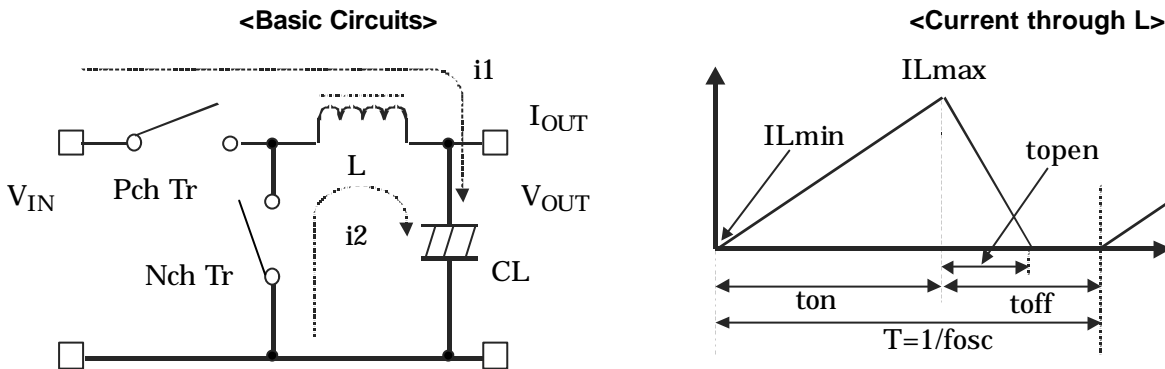

- Step 1: P-channel Tr. turns on and current $I_L (=i_1)$ flows, and energy is charged into CL . At this moment, I_L increases from $I_{Lmin}(=0)$ to reach I_{Lmax} in proportion to the on-time period(t_{on}) of P-channel Tr.
- Step 2: When P-channel Tr. turns off, Synchronous rectifier N-channel Tr. turns on in order that L maintains I_L at I_{Lmax} , and current $I_L (=i_2)$ flows.
- Step 3: $I_L (=i_2)$ decreases gradually and reaches $I_L=I_{Lmin}=0$ after a time period of t_{open} , and N-channel Tr. turns off. Provided that in the continuous mode, next cycle starts before I_L becomes to 0 because t_{off} time is not enough. In this case, I_L value increases from this $I_{Lmin}(> 0)$.

In the case of PWM control system, the output voltage is maintained by controlling the on-time period (t_{on}), with the oscillator frequency (f_{osc}) being maintained constant.

● Discontinuous Conduction Mode and Continuous Conduction Mode

The maximum value (I_{Lmax}) and the minimum value (I_{Lmin}) of the current flowing through the inductor are the same as those when P-channel Tr. turns on and off.

The difference between I_{Lmax} and I_{Lmin} , which is represented by ΔI ;

$$\Delta I = I_{Lmax} - I_{Lmin} = V_{OUT} \times t_{open} / L = (V_{IN} - V_{OUT}) \times t_{on} / L \dots \text{Equation 1}$$

Wherein $T = 1/f_{osc} = t_{on} + t_{off}$

$$\text{duty (\%)} = t_{on} / T \times 100 = t_{on} \times f_{osc} \times 100$$

$$t_{open} \leq t_{off}$$

In Equation 1, $V_{OUT} \times t_{open} / L$ and $(V_{IN} - V_{OUT}) \times t_{on} / L$ respectively show the change of the current at "ON", and the change of the current at "OFF".

When the output current (I_{OUT}) is relatively small, $t_{open} < t_{off}$ as illustrated in the above diagram. In this case, the energy is charged in the inductor during the time period of t_{on} and is discharged in its entirety during the time period of t_{off} , therefore I_{Lmin} becomes to zero ($I_{Lmin} = 0$). When I_{out} is gradually increased, eventually, t_{open} becomes to t_{off} ($t_{open} = t_{off}$), and when I_{OUT} is further increased, I_{Lmin} becomes larger than zero ($I_{Lmin} > 0$). The former mode is referred to as the discontinuous mode and the latter mode is referred to as continuous mode.

In the continuous mode, when Equation 1 is solved for t_{on} and assumed that the solution is t_{onC} ,

$$t_{on} = T \times V_{IN}/V_{OUT} \dots \text{Equation 2}$$

When $t_{on} < t_{on}$, the mode is the discontinuous mode, and when $t_{on} = t_{on}$, the mode is the continuous mode.

■ OUTPUT CURRENT AND SELECTION OF EXTERNAL COMPONENTS

When P-channel Tr. of Lx is ON:

(Wherein, Ripple Current P-P value is described as IRP, ON resistance of P-channel Tr. and N-channel Tr. of Lx are respectively described as Ronp and Ronn, and the DC resistor of the inductor is described as RL.)

$$V_{IN} = V_{OUT} + (R_{onp} + R_L) \times I_{OUT} + L \times I_{RP} / t_{on} \dots \text{Equation 3}$$

When P-channel Tr. of Lx is "OFF" (N-channel Tr. is "ON"):

$$L \times I_{RP} / t_{off} = R_L \times I_{OUT} + V_{OUT} + R_{onn} \times I_{OUT} \dots \text{Equation 4}$$

Put Equation 4 to Equation 3 and solve for ON duty of P-channel transistor, $t_{on} / (t_{off} + t_{on}) = D_{ON}$,

$$D_{ON} = (V_{OUT} - R_{onn} \times I_{OUT} + R_L \times I_{OUT}) / (V_{IN} - R_{onn} \times I_{OUT} - R_{onp} \times I_{OUT}) \dots \text{Equation 5}$$

Ripple Current is as follows;

$$I_{RP} = (V_{IN} - V_{OUT} - R_{onp} \times I_{OUT} - R_L \times I_{OUT}) \times D_{ON} / f_{osc} / L \dots \text{Equation 6}$$

wherein, peak current that flows through L, and Lx Tr. is as follows;

$$I_{Lmax} = I_{OUT} + I_{RP} / 2 \dots \text{Equation 7}$$

Consider ILmax, condition of input and output and select external components.

★The above explanation is directed to the calculation in an ideal case in continuous mode.

■ How to Adjust Output Voltage and about Phase Compensation

As for Adjustable Output type, feedback pin (VFB) voltage is controlled to maintain 0.8V.

Output Voltage, VOUT is as following equation;

$$V_{OUT} = R_1 + R_2 = V_{FB} : R_2 \\ V_{OUT} = V_{FB} \times (R_1 + R_2) / R_2$$

Thus, with changing the value of R1 and R2, output voltage can be set in the specified range.

In the DC/DC converter, with the load current and external components such as L and C, phase might be behind 180 degree. In this case, the phase margin of the system will be less and stability will be worse. To prevent this, phase margin should be secured with proceeding the phase. A pole is formed with external components L and COUT.

$$f_{pole} \sim 1 / (2\pi \sqrt{LC_{OUT}})$$

A zero (signal back to zero) is formed with R1 and Cb.

$$f_{zero} \sim 1 / (2\pi \times R_1 \times C_b)$$

First, choose the appropriate value of R1, R2 and Cb.

Set R1+R2 value 100kΩ or less.

For example, if L=10μH, COUT=10μF, the cut off frequency of the pole is approximately 16kHz.

To make the cut off frequency of the zero more than 16kHz, for example, set R1=42kΩ and Cb=100pF.

If VOUT is set at 1.5V, R2=48kΩ is appropriate.

If a ceramic capacitor is desirable as COUT in your application, nonetheless of the usage of both the fixed output voltage type and adjustable output type, add 0.2Ω or more resistance to compensate the ESR.

Further, if a ceramic capacitor is desirable to use as COUT without adding another resistor to compensate the ESR, phase should be back drastically. To make it, R2 value should be smaller compared to R1. As a result, the set output voltage may be large. For example, to make VOUT=1.5V, constants are R1=42kΩ, R2=48kΩ, and Cb=100pF. If the ceramic capacitor is used, under the heavy load condition, oscillation may be result. On the other hand, if R2=12kΩ and VOUT=3.6V, phase back becomes also large, and even if the device is used with a heavy load, the operation will be stable. Rb is effective for reducing the noise on VFB, however, it is not always necessary. If it is necessary, use as much as 30kΩ as Rb.

External Components

1. Inductor

Select an inductor that peak current does not exceed I_{Lmax} . If larger current than allowable current flows, magnetic saturation occurs and make transform efficiency worse.

Supposed that the load current is at the same, the smaller value of L is used, the larger the ripple current is.

Provided that the allowable current is large in that case and DC current is small, therefore, for large output current, efficiency is better than using an inductor with a large value of L and vice versa.

2. Capacitor

As for C_{IN} , use a capacitor with low ESR (Equivalent Series Resistance) Ceramic type of a capacity at least $10\mu F$ for stable operation.

C_{OUT} can reduce ripple of Output Voltage, therefore as much as $10\mu F$ tantalum type is recommended.

TIMING CHART

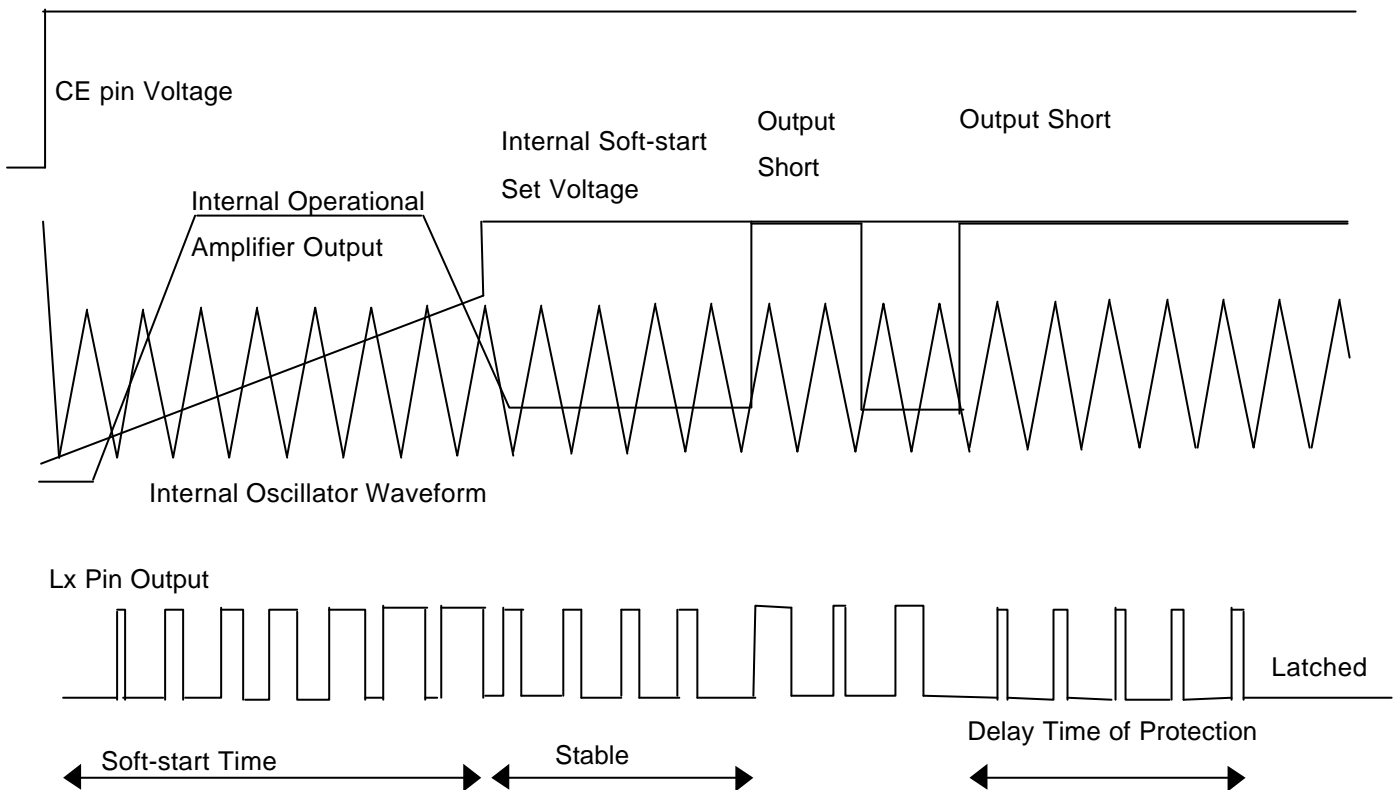

The timing chart as shown above describes the waveforms starting from the IC is enabled with CE and latched with protection. During the soft-start time, until the level is rising up to the internal soft-start set voltage, the duty cycle of Lx is gradually wider and wider to prevent the over-shoot of the voltage. During the term, the output of amplifier is "H", then after the output voltage reaches the set output voltage, they are balanced with the stable state. Herein, if the output pin would be short circuit, the output of amplifier would become "H" again, and the condition would continue for 1.5ms (TYP.), latch circuit would work and the output of Lx would be latched with "OFF". (Output = "High-Z")

If the output short is released before the latch circuit works (within 1.5ms after output shorted), the output of amplifier is balanced in the stable state again.

Once the IC is latched, to release the protection, input "L" with CE pin, or make the supply voltage at UVLO level or less.

TYPICAL CHARACTERISTICS

1) Output Voltage vs. Output Current

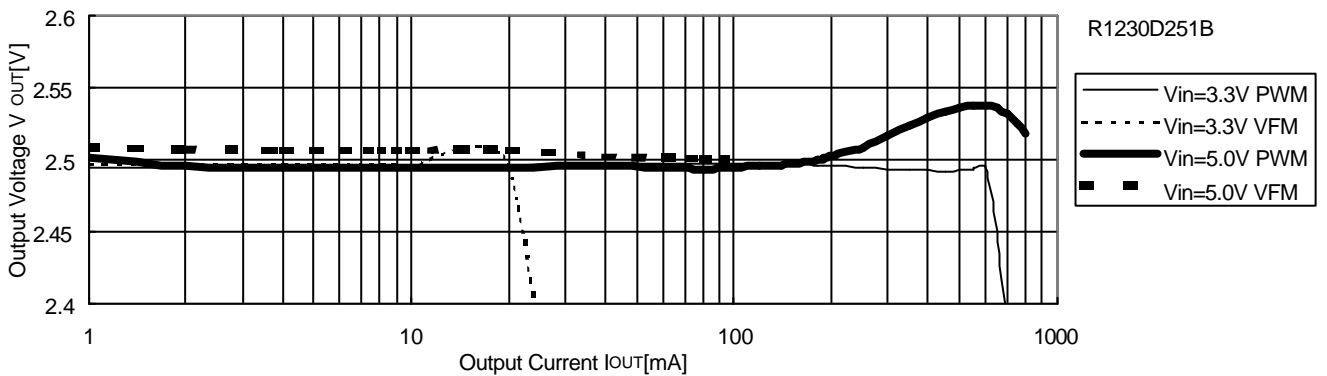
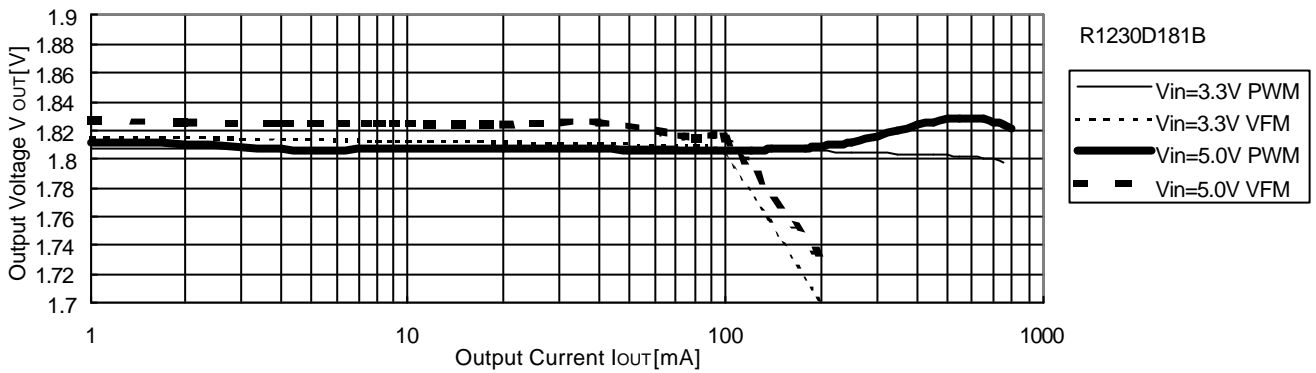
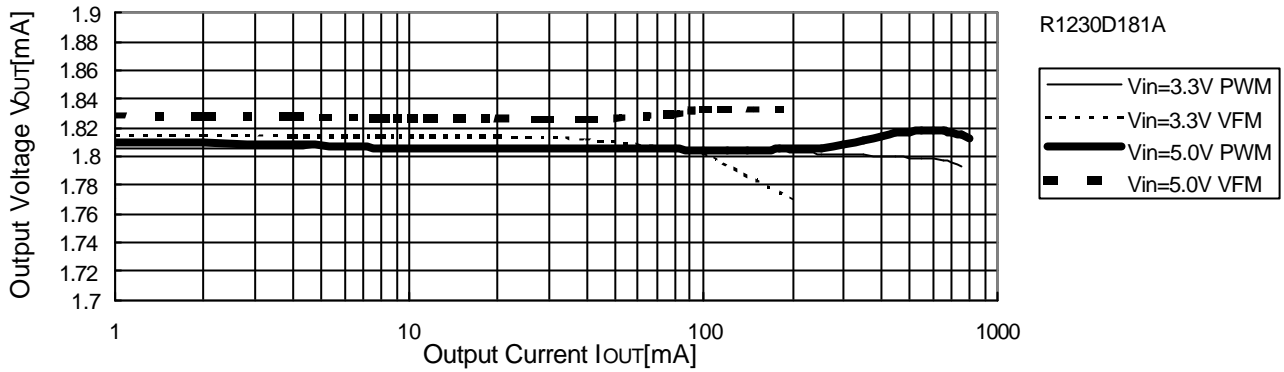

2) Efficiency vs. Output Current

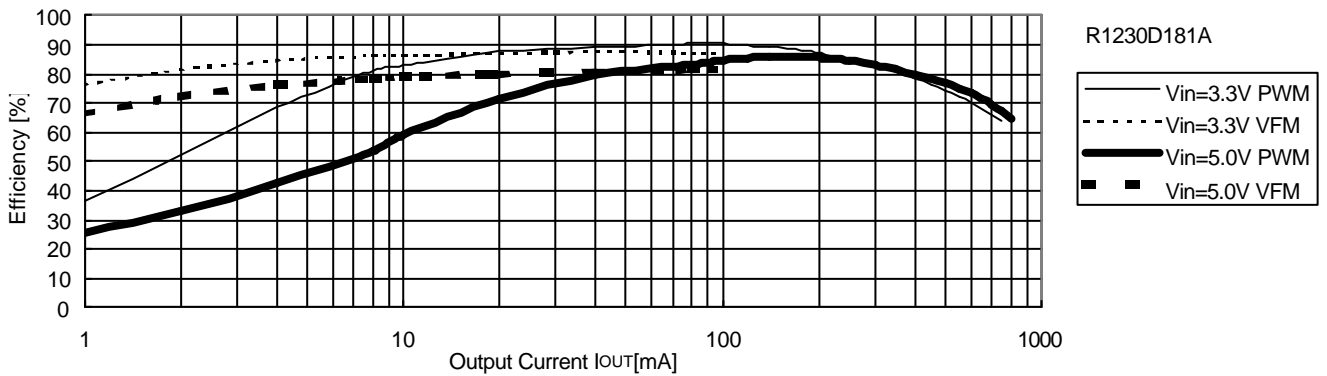

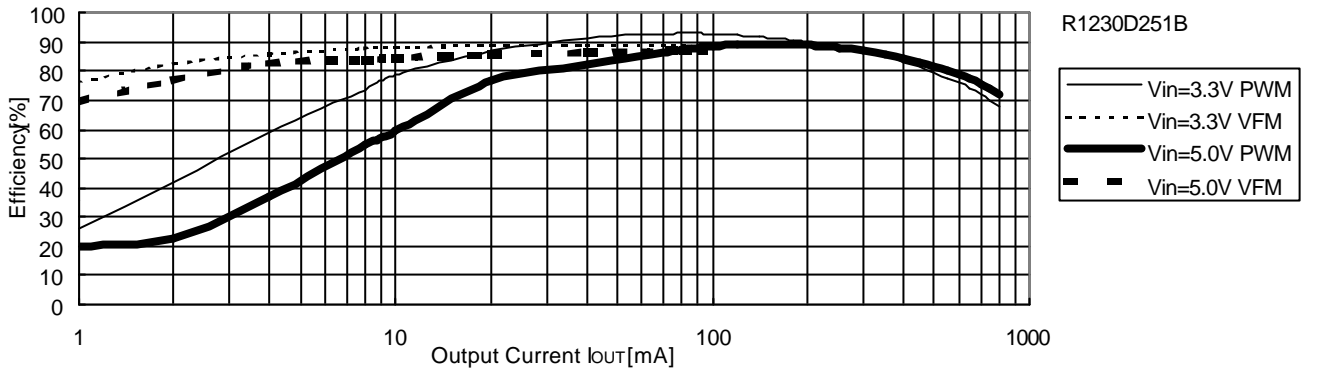
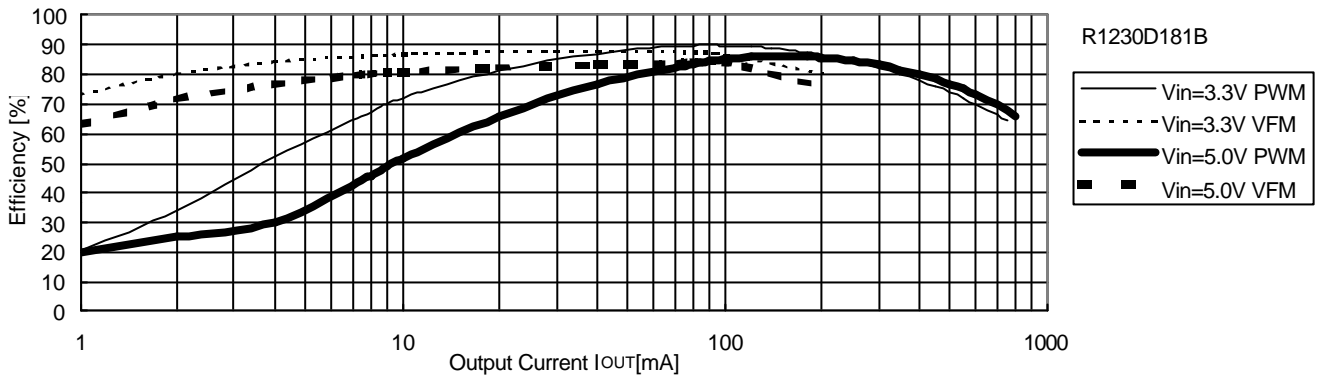

3) Ripple Voltage vs. Output Current

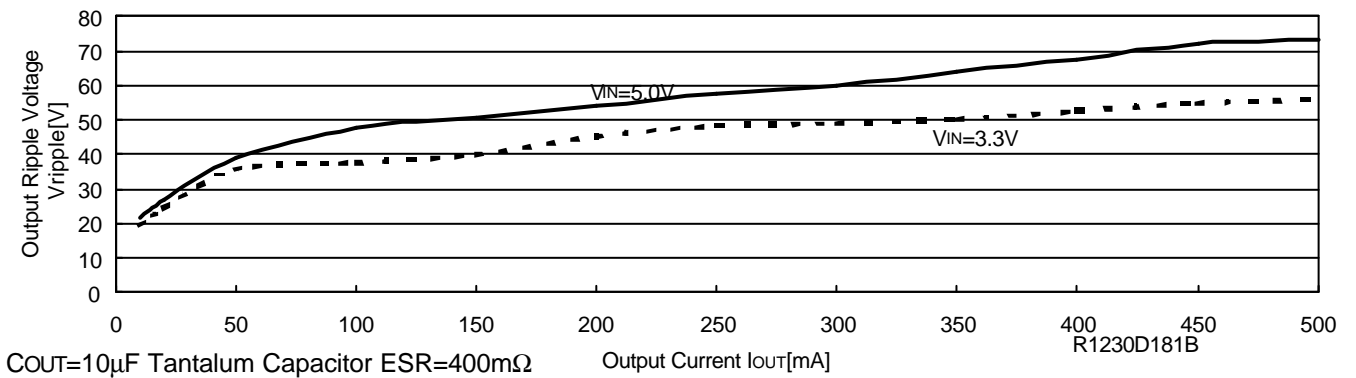
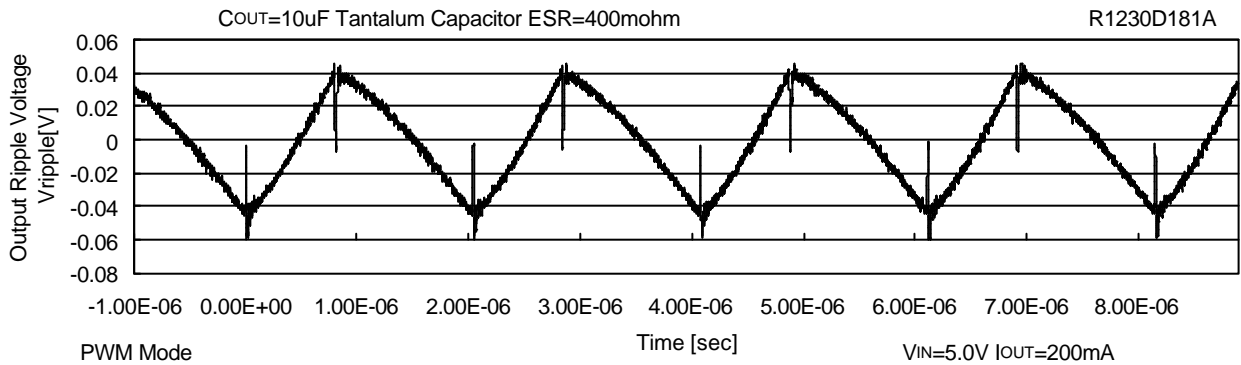

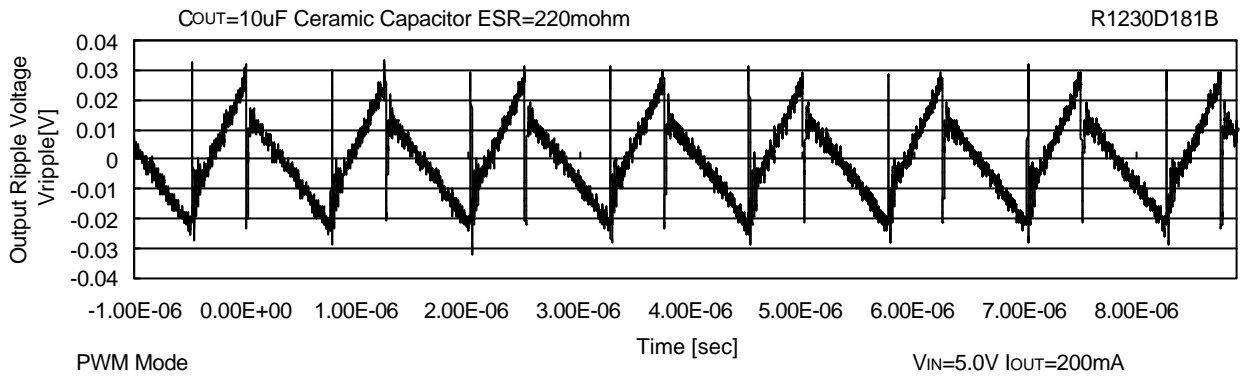

4) Output Waveform

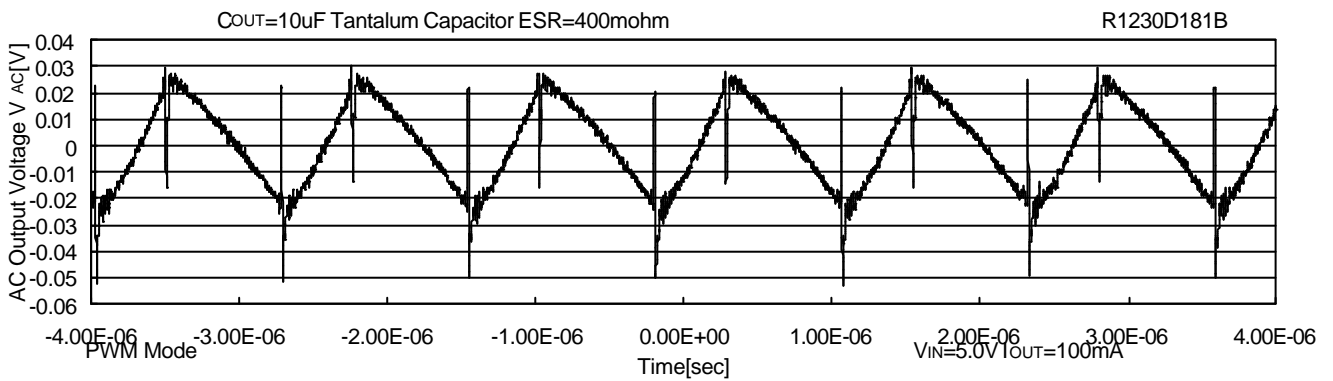
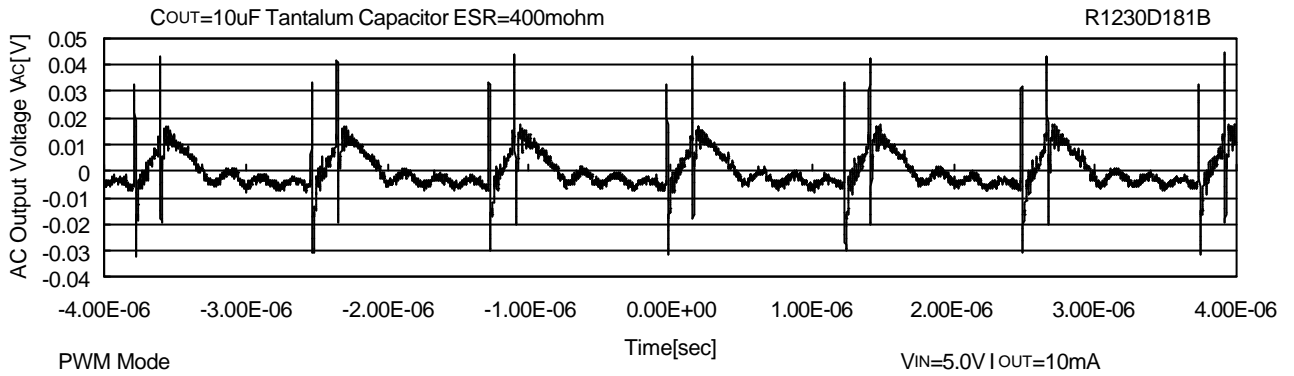

5) Output Voltage vs. Input Voltage

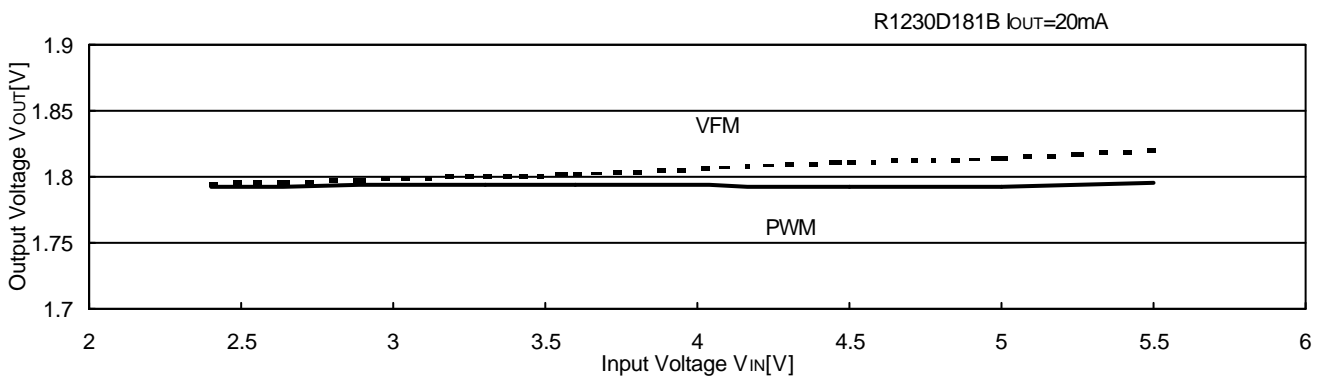

6) Output Voltage vs. Temperature

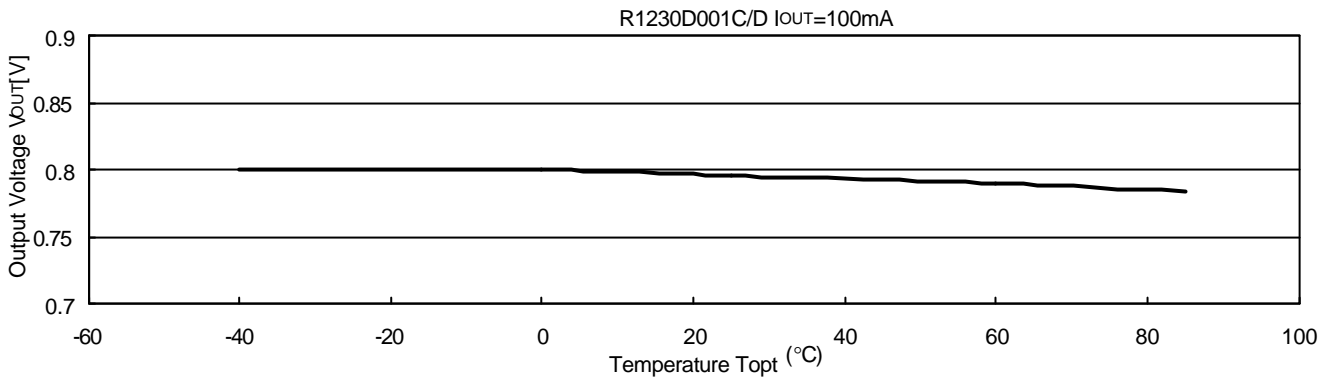
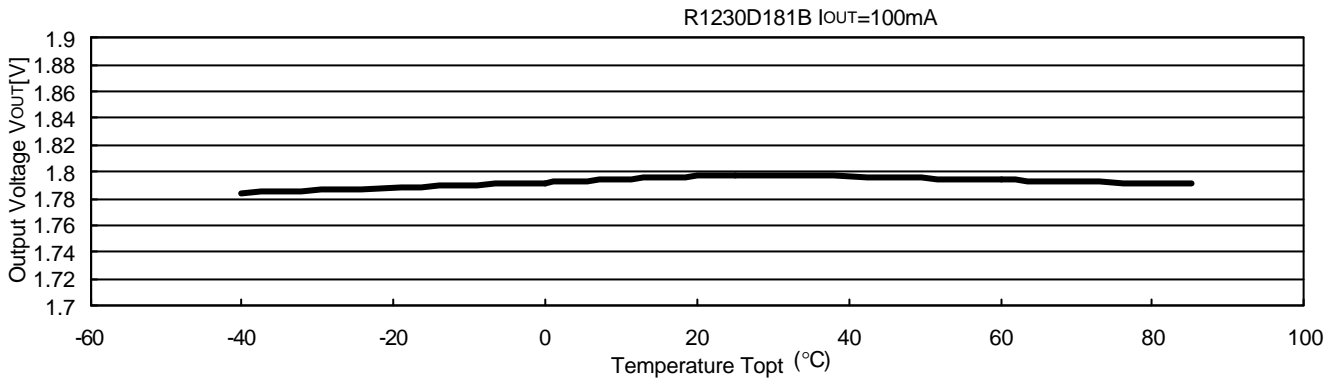

7) Oscillator Frequency vs. Temperature

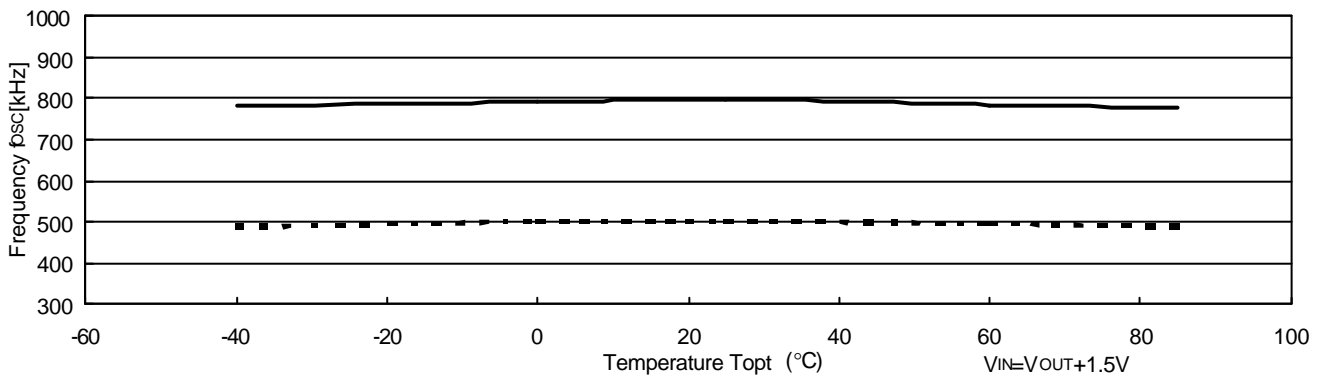

8) Supply Current vs. Temperature

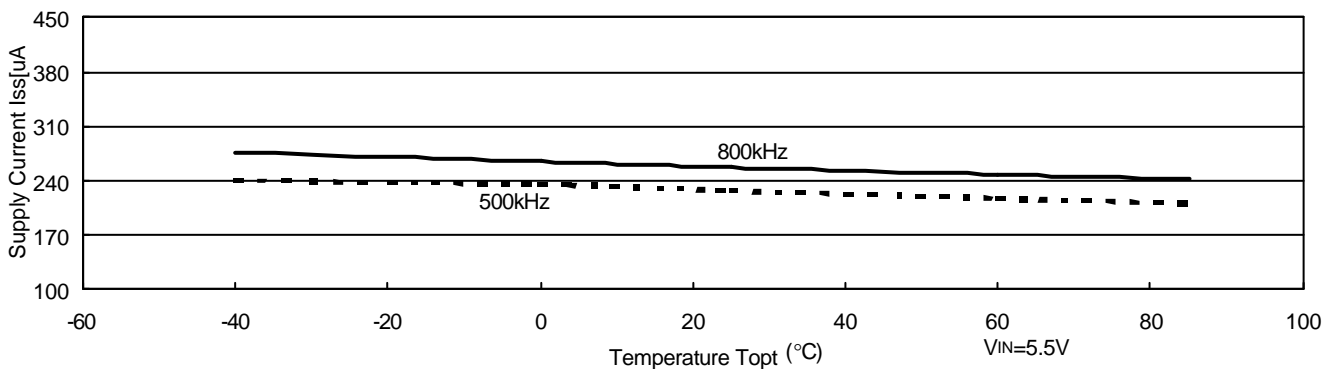

9) Soft-start time vs. Temperature

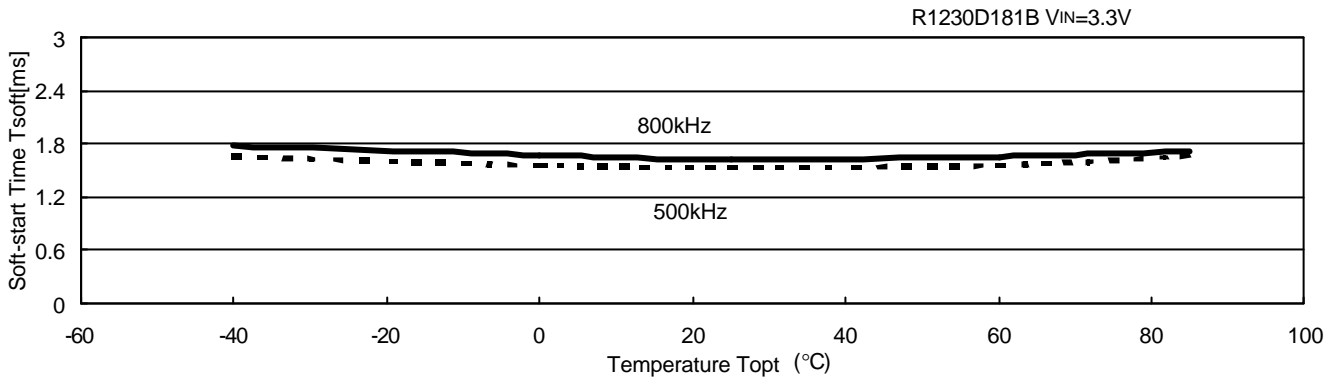

10) Delay Time for protection vs. Temperature

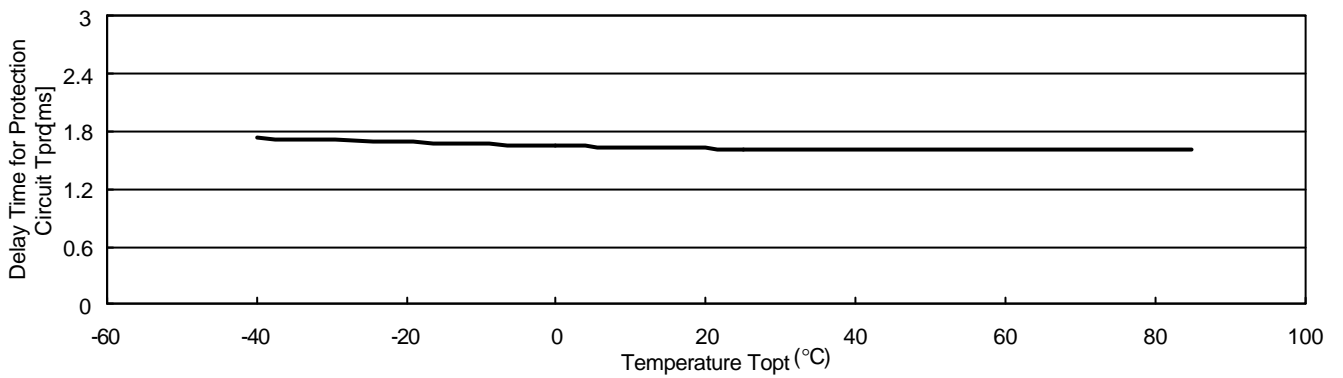

11) UVLO Threshold/Released Voltage vs. Temperature

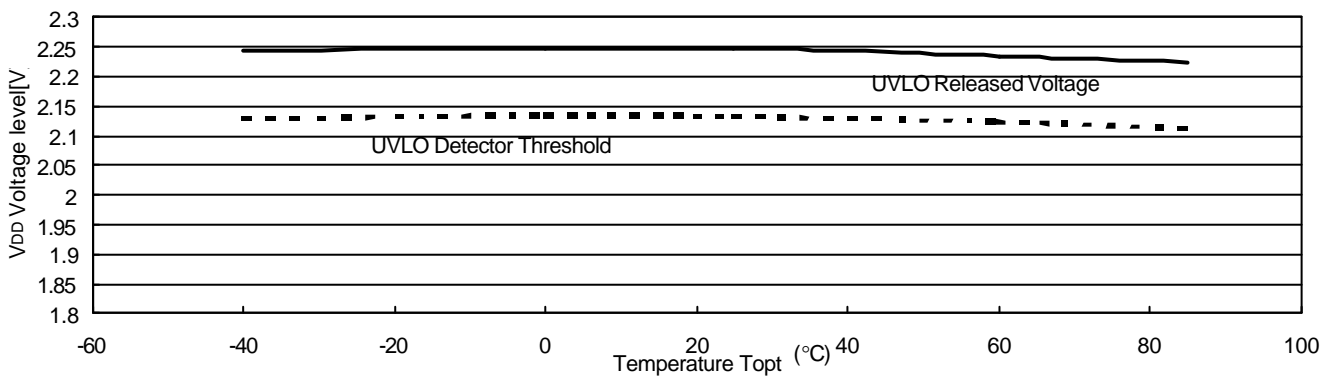

12) CE Pin Input Voltage vs. Temperature

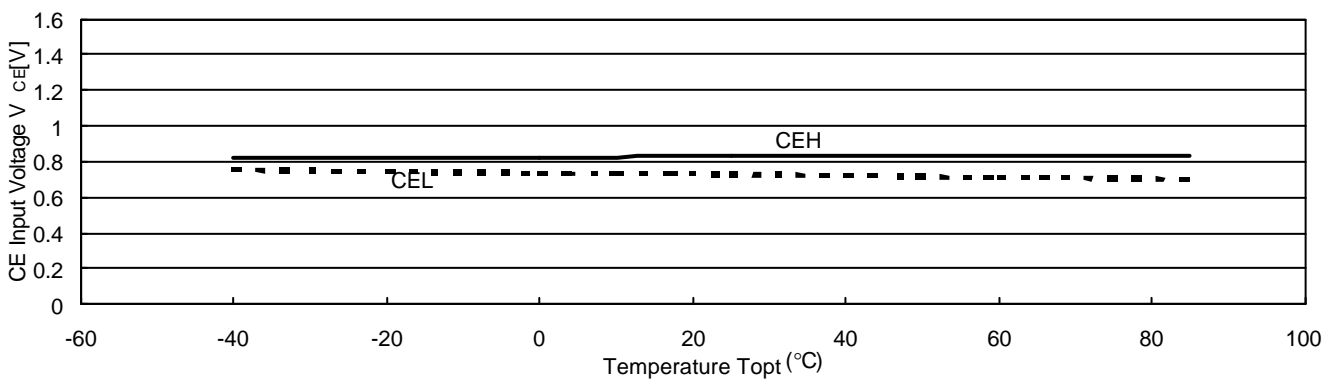

13) Mode Pin Input Voltage vs. Temperature

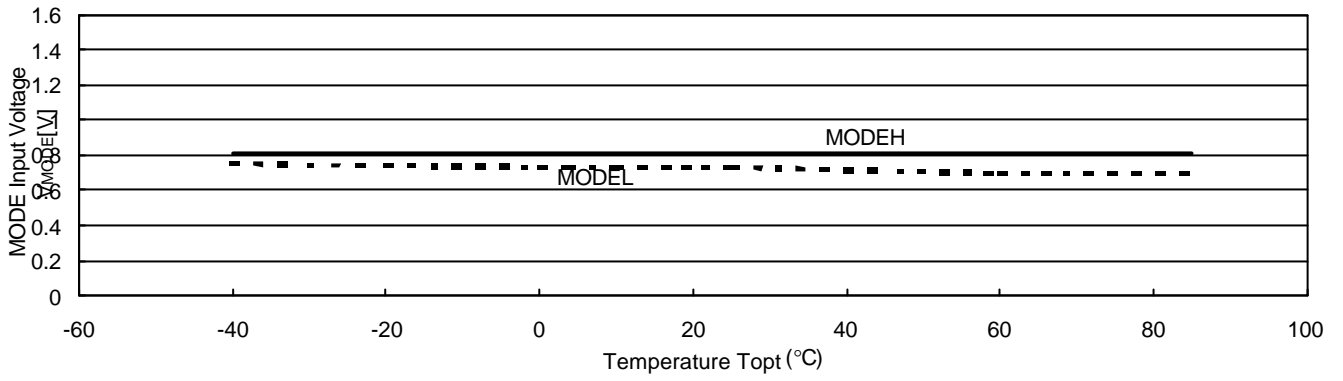

14) Duty Cycle at VFM Mode vs. Temperature

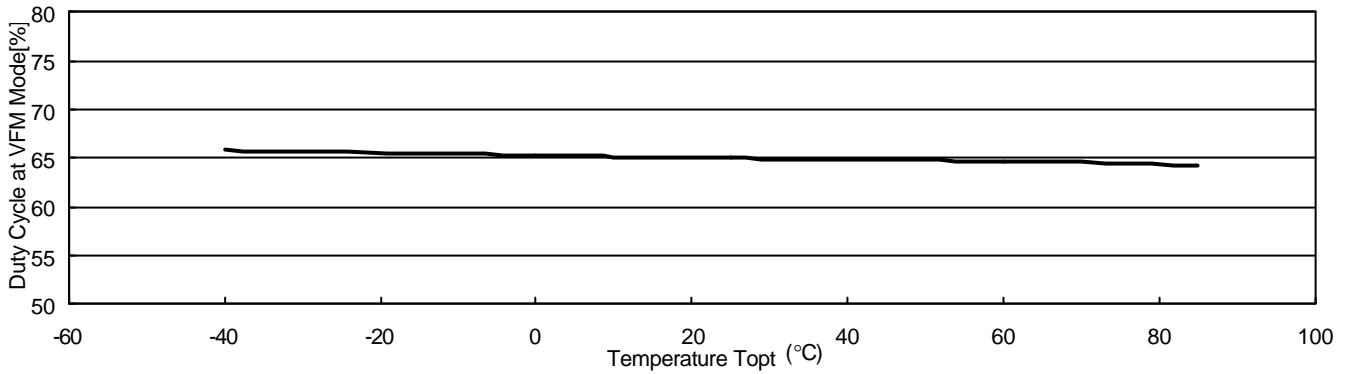

15) Lx Transistor on Resistance vs. Temperature

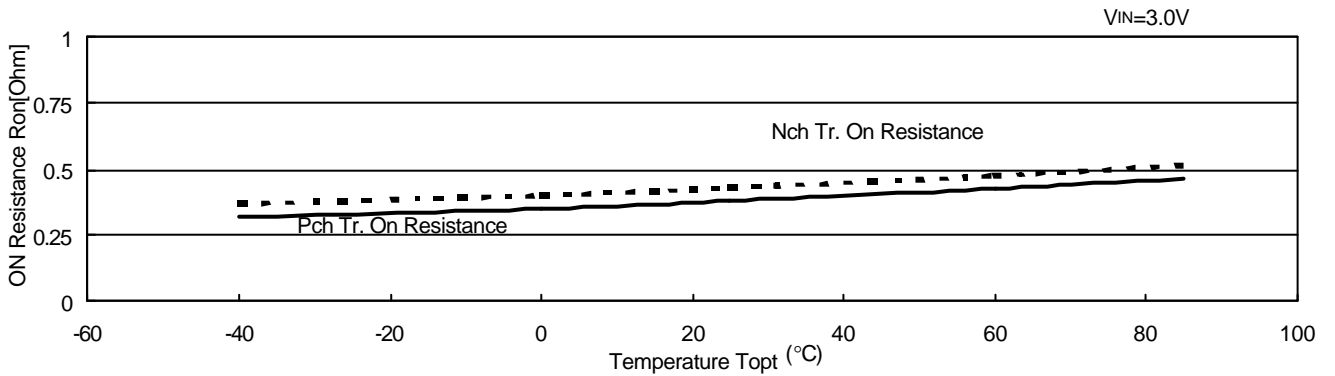

16) Limit Voltage vs. Temperature

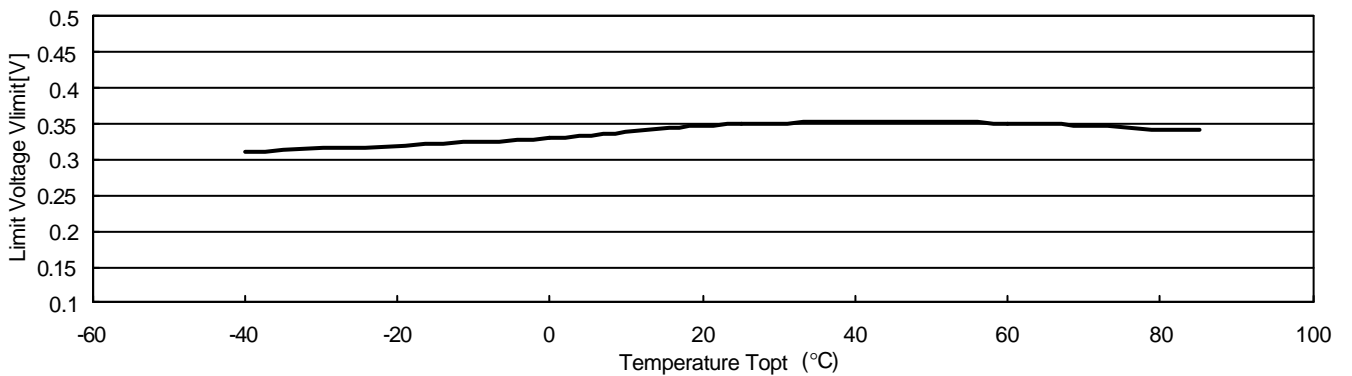

17) Load Transient Response

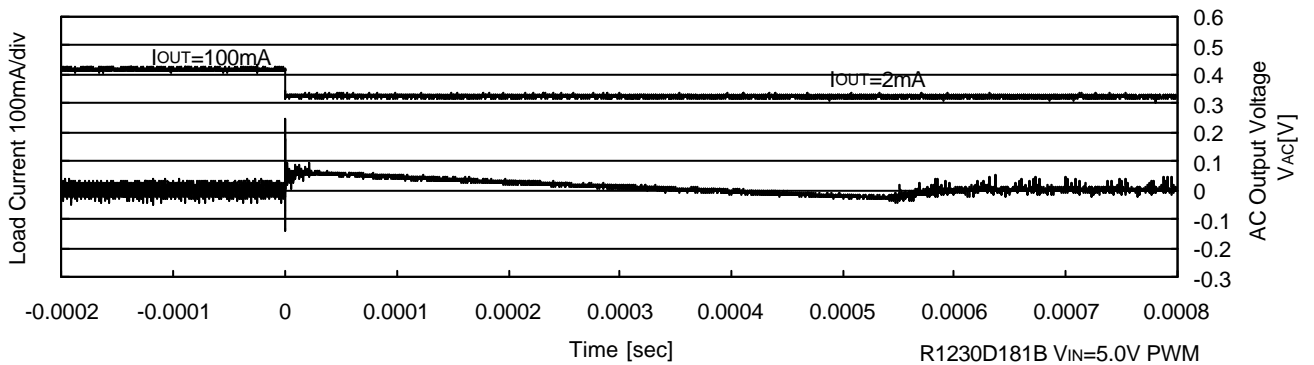
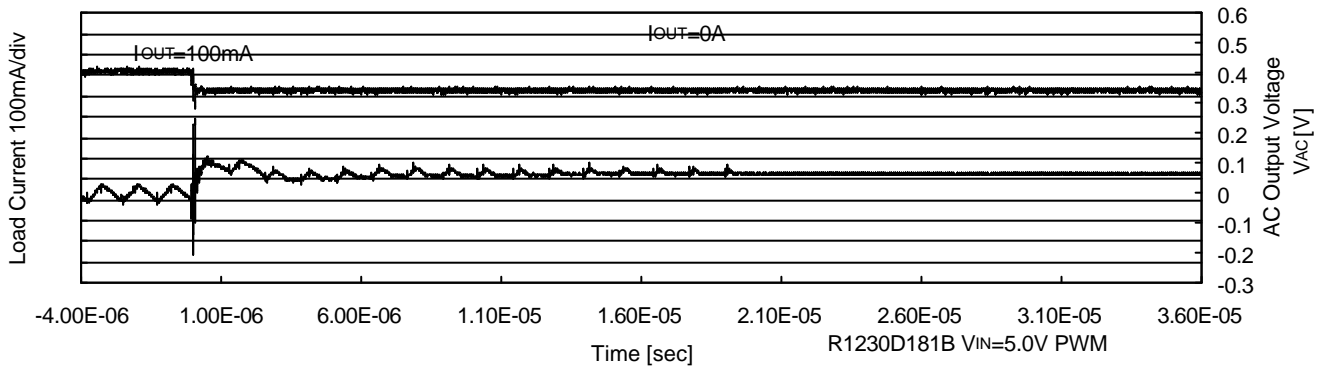
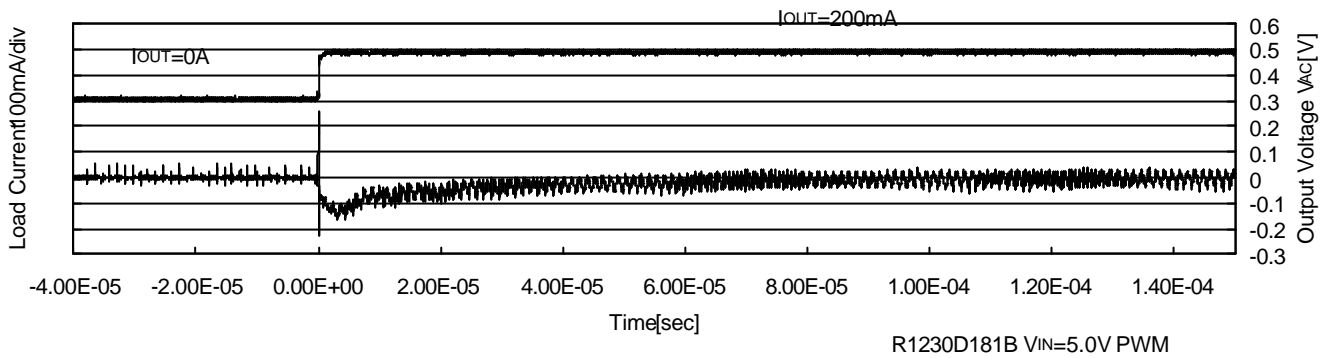
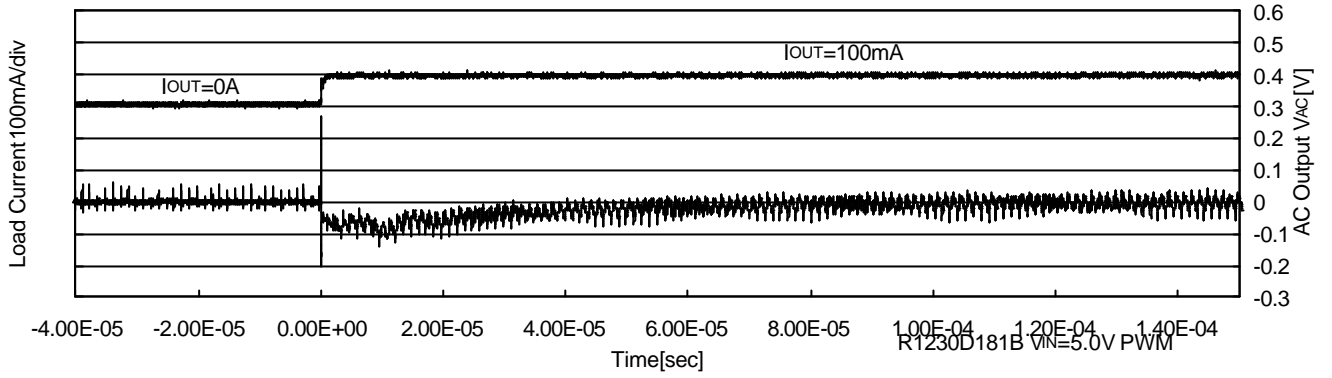

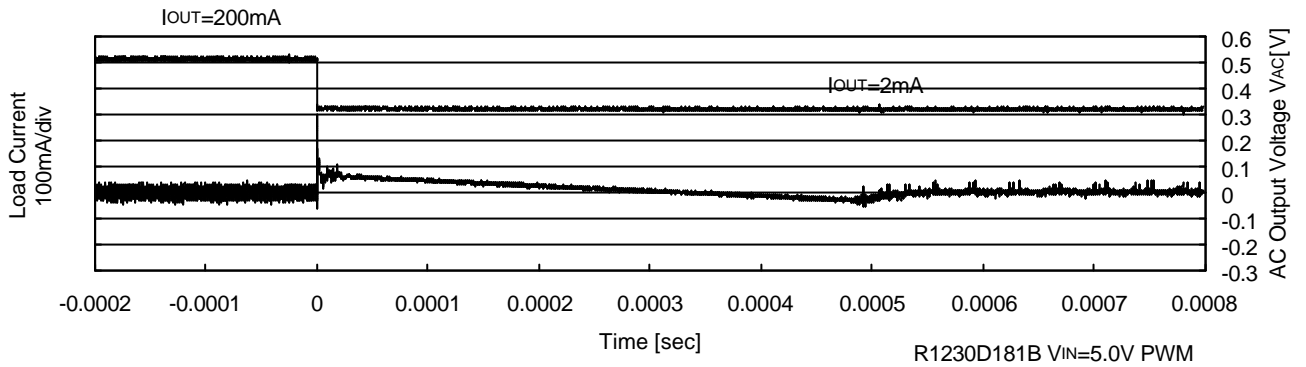
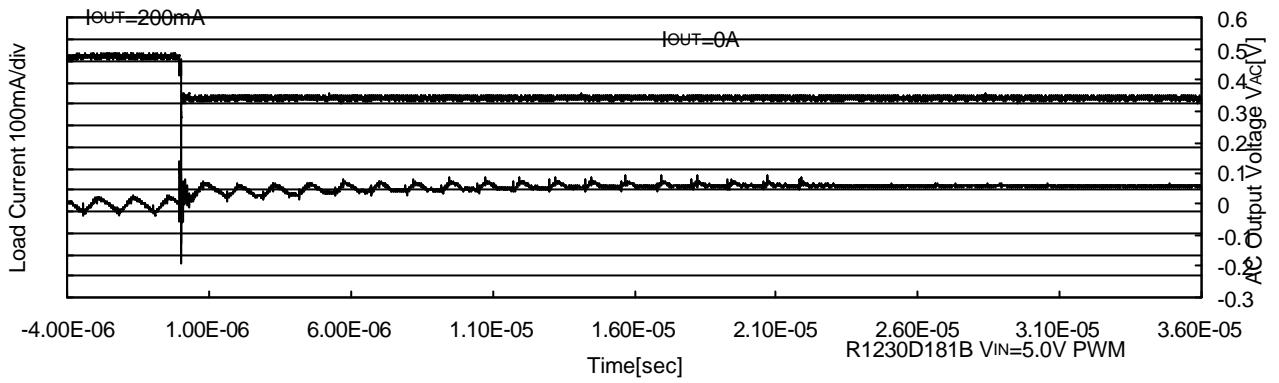

18) Turn-on Waveform

